

25 Frame Piston Pump

Standard Brass Models	1520, 2520
Stainless Steel Models	1521, 2521
Pulse Pump Manifold Models	1525, 2525
Hi-Temp Model	2520C

FEATURES

Superior Design

- Triplex Uniflow design provides continuous forward liquid flow for smooth operation.
- Wetted cups and floating pistons are lubricated and cooled by pumped liquid for long cup life.
- Mechanically actuated inlet valves give strong lift and easy prime.
- 304 stainless steel flat valve design offers positive seating and greater suction capabilities.
- Oil bath crankcase assures optimum lubrication.

Quality Materials

- Cylinder and sleeve wear surfaces are hard chrome plated 304 stainless steel for maximum durability and abrasion resistance.
- Chrome plated, brass manifolds and optional stainless steel manifolds are strong and corrosion resistant.
- Special high strength TNM connecting rods offer superior bearing quality strength.
- Chrome-moly crankshaft gives unmatched strength and surface hardness.
- Oversized crankshaft bearings with greater loading capacity mean longer bearing life.

Easy Maintenance

- Stepped stainless steel piston rod and with chrome-plated, stainless steel sleeve allows easy replacement from front of pump.
- All wet-end wear parts are easily serviced without entering crankcase, requiring less time and effort.
- Wear parts are available in convenient kits.

⚠ WARNING

All systems require both a primary pressure regulating device (i.e., regulator, unloader) and a secondary pressure safety relief device (i.e., pop-off valve, safety valve). Failure to install such relief devices could result in personal injury or damage to the pump or to system components. CAT PUMPS does not assume any liability or responsibility for the operation of a customer's high pressure system.

SPECIFICATIONS

	U.S. Measure	Metric Measure
MODEL 1520, 1521, 1525		
Flow	15 GPM	(57 L/M)
Pressure Range	100 to 1000 PSI	(7 to 70 BAR)
RPM	830 RPM	(830 RPM)
Bore	1.122"	(28.5 mm)

MODEL 2520, 2521, 2525 and 2520C

Flow	25 GPM	(95 L/M)
Pressure Range	100 to 800 PSI	(7 to 55 BAR)
RPM	772 RPM	(772 RPM)
Bore	1.490"	(38 mm)
Inlet Pressure Range	Flooded to +40 PSI	(Flooded to +2.8 BAR)
Maximum Liquid Temperature	210°F	(98°C)
Flushing Ports (2)	1/4" NPTF	(1/4" NPTF)
Dimensions	21.42 x 15.04 x 7.8"	(544 x 382 x 198 mm)

COMMON SPECIFICATIONS

Stroke	1.417"	(36 mm)
Inlet Pressure Range	-8.5 to +40 PSI	(-0.6 to +2.8 BAR)
Crankcase Capacity84 oz.	(2.5 L)
Maximum Liquid Temperature	160°F	(71°C)
Above 130°F call CAT PUMPS for inlet conditions and elastomer recommendations.		
Inlet Ports (1)	1-1/4" NPTF	(1-1/4" NPTF)
Discharge Ports (3)	1" NPTF	(1" NPTF)
Pulley Mounting	Either side	(Either side)
Shaft Diameters	1.181"	(30 mm)
Weight	69.3 lbs.	(31.5 kg)
Dimensions	21.62 x 15.04 x 7.8"	(549.15 x 382 x 198 mm)

ELECTRIC HORSEPOWER REQUIREMENTS

MODEL	FLOW		PRESSURE			MOTOR PULLEY SIZE Using 1725 RPM Motor & Std. 9.75" Pulley O.D.	
	U.S. GPM	L/M	PSI 800 BAR 55	PSI 1000 BAR 70	PSI 1200 BAR 85	RPM	Pulley O.D.
1520, 1521 and 1525	15	57	8.2	10.3	N/A	830	4.7
	12	45	6.6	8.2	N/A	660	3.8
	10	38	5.5	6.9	N/A	550	3.1
2520, 2521, 2525 and 2520C	25	95	13.7	N/A	N/A	772	4.4
	20	76	11.0	N/A	N/A	620	3.5
	15	57	8.2	N/A	N/A	465	2.7

DETERMINING THE PUMP R.P.M.	<u>Rated G.P.M.</u>	=	<u>"Desired" G.P.M.</u>
	<u>Rated R.P.M.</u>	=	<u>"Desired" R.P.M.</u>
DETERMINING THE REQUIRED H.P.	<u>GPM x PSI</u>	=	<u>Electric Brake</u>
	1460	=	<u>H. P. Required</u>
DETERMINING MOTOR PULLEY SIZE	<u>Motor Pulley O.D.</u>	=	<u>Pump Pulley O.D.</u>
	<u>Pump R.P.M.</u>	=	<u>Motor R.P.M.</u>

See complete Drive Packages [Incls: Pulleys, Belts, Hubs, Key] Tech Bulletin 003.
Refer to pump **Service Manual** for repair procedure, additional technical information and **pump warranty**.

"Customer confidence is our greatest asset"

PARTS LIST

ITEM	PART NUMBER						DESCRIPTION	QTY
	1520		2520		2520C			
	1521		2521					
	1525	MATL	2525	MATL	2520C	MATL		
2	990036	STL	990036	STL	990036	STL	Key (M8x7x40) [3/00]	1
5	92508	STZP	92508	STZP	92508	STZP	Screw, HHC, Sems (M8x25)	8
	126544	STCP R	126544	STCP R	126544	STCP R	Screw, HHC, Sems (M8x25)	8
8	27773	AL	27773	AL	27773	AL	Cover, Bearing	2
10	27772	NBR	27772	NBR	27772	NBR	O-Ring, Bearing Cover - 70D	2
11	27771	NBR	27771	NBR	27771	NBR	Seal, Oil, Crankshaft - 70D	2
15	26512	STL R	26512	STL R	26512	STL R	Bearing, Ball	2
20	48613	TNM	48613	TNM	48613	TNM	Rod, Connecting	3
21	126562	STCP R	126562	STCP R	126562	STCP R	Washer, Locking	3
25	48704	FCM	48704	FCM	48704	FCM	Crankshaft [3/00]	1
31	828710	—	828710	—	828710	—	Protector, Oil Cap w/Foam Gasket	1
32	43211	ABS	43211	ABS	43211	ABS	Cap, Oil Filler	1
33	14177	NBR	14177	NBR	14177	NBR	O-Ring, Oil Filler Cap - 70D	1
38	11338	NBR	11338	NBR	11338	NBR	O-Ring, Dipstick - 70D	1
39	27769	ABS	27769	ABS	27769	ABS	Dipstick	1
40	92508	STZP	92508	STZP	92508	STZP	Screw, HHC, Sems (M8x25)	8
	126544	STCP R	126544	STCP R	126544	STCP R	Screw, HHC, Sems (M8x25)	8
48	25625	STCP	25625	STCP	25625	STCP	Plug, Drain (1/4"x19BSP)	1
49	23170	NBR	23170	NBR	23170	NBR	O-Ring, Drain Plug - 70D	1
50	27768	AL	27768	AL	27768	AL	Cover, Rear	1
51	27767	NBR	27767	NBR	27767	NBR	O-Ring, Rear Cover - 70D	1
53	27762	AL	27762	AL	27762	AL	Crankcase, w/Guide Pins	1
54	27488	S	27488	S	27488	S	Pin, Guide	2
55	27764	STZP	27764	STZP	27764	STZP	Stud (M12x53)	4
	126547	STCP R	126547	STCP R	126547	STCP R	Stud (M12x53)	4
56	27790	POP	27790	POP	27790	POP	Pan, Oil	1
59	92519	STZP	92519	STZP	92519	STZP	Screw, HHC, Sems (M6x16)	2
	125824	STCP R	125824	STCP R	125824	STCP R	Screw, HHC, Sems (M6x16)	2
64	27784	CM	27784	CM	27784	CM	Pin, Crosshead	3
65	29229	SZZ	29229	SZZ	43266	SZZ	Rod, Piston (M8)	3
70	27785	NBR	27785	NBR	27785	NBR	Seal, Oil, Crankcase - 70D	3
75	27786	S	27786	S	27786	S	Slinger, Barrier	3
77	26531	NBR	26531	NBR	14198	FPM	O-Ring, Sleeve	6
	14198	FPM	14198	FPM	—	—	O-Ring, Sleeve	6
80	43122	SCP	43122	SCP	43122	SCP	Sleeve (M16)	3
	43123	S	43123	S	43123	S	Sleeve (M16) - Unchromed	3
81	29246	PTFE	29246	PTFE	29246	PTFE	Back-up-Ring, Sleeve	3
100	27788	PVDF	27788	PVDF	27788	PVDF	Retainer, Seal	3
101	43126	—	43126	—	43126	—	Wick, Long Tab (M16)	3
103	—	—	—	—	43269	FPM	Seal w/Lip	3
104	—	—	—	—	14178	NBR	O-Ring, Seal Adapter	3
105	—	—	—	—	43268	S	Adapter, LPS	3
106	43124	NBR	43124	NBR	43272	FPM	Seal (M16)/Seal w/Grease Pocket	3
	43125	FPM	43125	FPM	—	—	Seal (M16)	3
110	27791	BBCP	27791	BBCP	43270	BBCP	Manifold, Inlet	1
	28595	SS	28595	SS	—	—	Manifold, Inlet	1
114	—	—	—	—	46148	S	Spacer, Inlet Valve	3
116	—	—	—	—	14198	FPM	O-Ring, Spacer	3
119	29232	S	29240	S	29240	S	Valve, Inlet (M8)	3
130	27814	S	27840	S	—	—	Piston	3
133	27815	FPM	28409	FPM	—	—	Cup, Piston	3
	30189	TG	30498	TR	30498	TR	Cup-Piston, Assy (1000 PSI MAX)	3
	29092	SNG	29094	SNG	—	—	Cup, V-Hot	3
135	29231	S	29231	S	29231	S	Spacer, Piston (M8)	3
136	29233	S	29239	S	29239	S	Retainer, Piston (M8)	3
137	27871	S	27871	S	27871	S	Washer, Conical (M8)	3
138	27510	S	27510	S	27510	S	Nut, Slotted (M8)	3
139	29589	S	29589	S	29589	S	Cotterpin (M2x18)	3
143	25495	NBR	25495	NBR	11748	FPM	O-Ring, Cylinder - 70D	6
	11748	FPM	11748	FPM	—	—	O-Ring, Cylinder - 70D	6
150	27817	SCP	27844	SCP	27844	SCP	Cylinder, (M65)	3
	29047	S	29049	S	29049	S	Cylinder, (M65) - Unchromed	3
153	48371	D	—	—	—	—	Back-up-Ring, Cylinder	3
163	28395	NBR	28395	NBR	28769	FPM	O-Ring, Valve Seat	3
	28769	FPM	28769	FPM	—	—	O-Ring, Valve Seat	3
164	28396	S	28396	S	28396	S	Seat	3
166	43133	S	43133	S	43133	S	Valve	3
167	26548	S	26548	S	26548	S	Spring	3
168	43134	S	43134	S	43134	S	Retainer, Spring	3
185	27805	BBCP	27805	BBCP	27805	BBCP	Manifold, Discharge	1
	28594	SS	28594	SS	—	—	Manifold, Discharge	1
	6425	BB	6425	BB	—	—	Manifold, Pulse Pump, Ported	1
186	126570	STCP R	126570	STCP R	126570	STCP R	Lockwasher (1/2")	4
187	27803	STCP	27803	STCP	43277	STCP	Bolt, Cylinder	4
188	126586	STCP R	126586	STCP R	126586	STCP R	Shim, Washer (M12x0.3)	4/8
189	126580	STCP R	126580	STCP R	126580	STCP R	Shim, Washer (M12x0.5)	4/8
190	126581	STCP R	126581	STCP R	126581	STCP R	Shim, Washer (M12x1.0)	4/8
191	27933	STZP	27933	STZP	27933	STZP	Lockwasher (M12)	4
193	126570	STCP R	126570	STCP R	126570	STCP R	Lockwasher (1/2")	4
194	81060	STZP	81060	STZP	81060	STZP	Nut, Hex (M12)	4
	126523	STCP R	126523	STCP R	126523	STCP R	Nut, Hex (M12)	4
196	27807	BBCP	27807	BBCP	27807	BBCP	Plug (1"NPTM)	1

EXPLODED VIEW

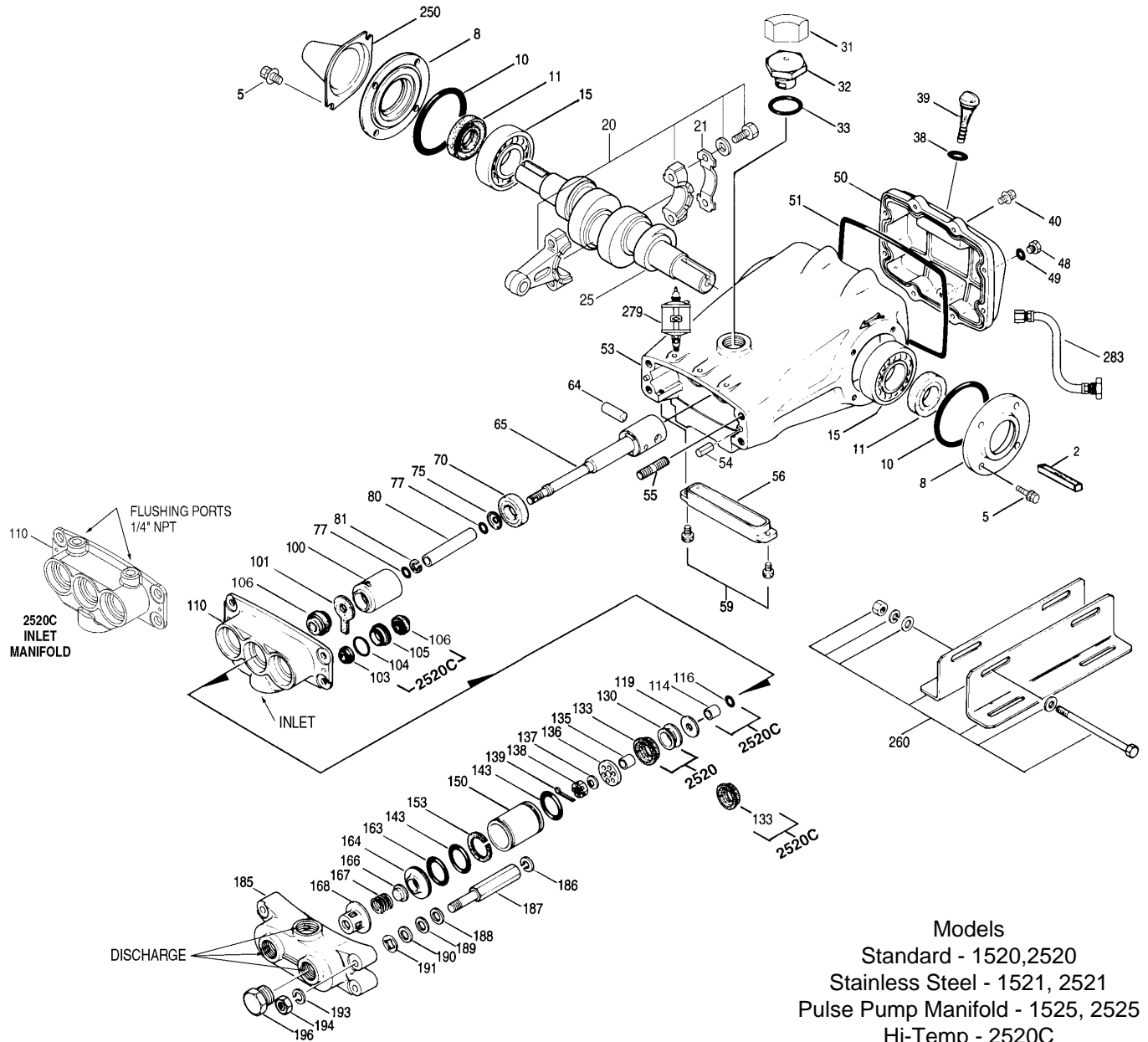

Models
 Standard - 1520,2520
 Stainless Steel - 1521, 2521
 Pulse Pump Manifold - 1525, 2525
 Hi-Temp - 2520C
 May 2008

	1520		2520		2520C			
	1521	MATL	2521	MATL	2520C	MATL		
250	26516	STCP	26516	STCP	26516	STCP	Protector, Shaft	1
260	30614	STZP	30614	STZP	30614	STZP	Mount, Rail, Assy	1
269	30206	F	30206	F	30206	F	Pulley (10") (See Drive Packages, Tech Bulletin 003)	1
275	30059	STL	30059	STL	30059	STL	Hub, "H" M30 (M8 Keyway) [3/00] (See Drive Packages, Tech Bulletin 003)	1
279	30278	STZP	30278	STZP	30278	STZP	Oiler (1 oz.)	3
281	30967	—	30967	—	30967	—	Oiler, Glass	3
282	10069	NBR	10069	NBR	10069	NBR	Gasket, Oiler	1
283	34334	—	34334	—	34334	—	Kit, Oil Drain	1
295	6300	BBSS	6300	BBSS	—	—	Pump, Pulse (1 qt.) 1000 PSI (See Individual Data Sheet)	1
295	6305	BBSS	6305	BBSS	—	—	Pump, Pulse (1 gal.) 1000 PSI (See Individual Data Sheet)	1
300	30254	FPM	30256	FPM	—	—	Kit, Cup (Incls: 133,139,143,153,355)	1
302	30839	NBR	30252	NBR	—	—	Kit, Piston (Incls: 119-143,153,355)	1
305	30819	NBR	30819	NBR	—	—	Kit, Sleeve & Seal (Incls: 75,77,80,101,106,139)	1
306	30482	NBR	30482	NBR	—	—	Kit, Seal (Incls: 101,106,139)	1
310	30767	NBR	30767	NBR	30767	NBR	Kit, Valve (Incls: 143,153,163,164,166,167,168)	1
355	15770	NY	27853	NY	—	—	Insertor, Cup	1
—	6100	—	6100	—	6100	—	Oil, Case (12 Bottles) ISO 68 Multi-viscosity Hydraulic (Fill to specified crankcase capacity prior to start-up)	1

Bold part numbers are unique to a particular pump model. *Italics are optional items.* [] Date of latest production change.

R Components comply with RoHS Directive. See Tech Bulletins 002, 003, 008, 009, 017, 021, 024, 034, 036, 063, 064, 074, 077, 083 and 085 for additional information.
 MATERIAL CODES (Not Part of Part Number): ABS=ABS Plastic AL=Aluminum BB=Brass BBCP=Brass/Chrome Plated CM=Chrome-Moly D=Acetal F=Cast Iron
 FCM=Forged Chrome-Moly FPM=Fluorocarbon NBR=Medium Nitrile (Buna-N) NY=Nylon POP=Polypropylene PTFE=Pure Polytetrafluoroethylene
 PVDF=Polyvinylidene Fluoride S=304SS SCP=304SS/Chrome Plated SNG=Special Blend (Buna) SS=316SS STCP=Steel/Chrome Plated STL=Steel
 STZP=Steel/Zinc Plated SZZ=304SS/Zamak TG=PTFE Graphite Compound (GIT) TNM=Special High Strength TR=PTFE-RLN

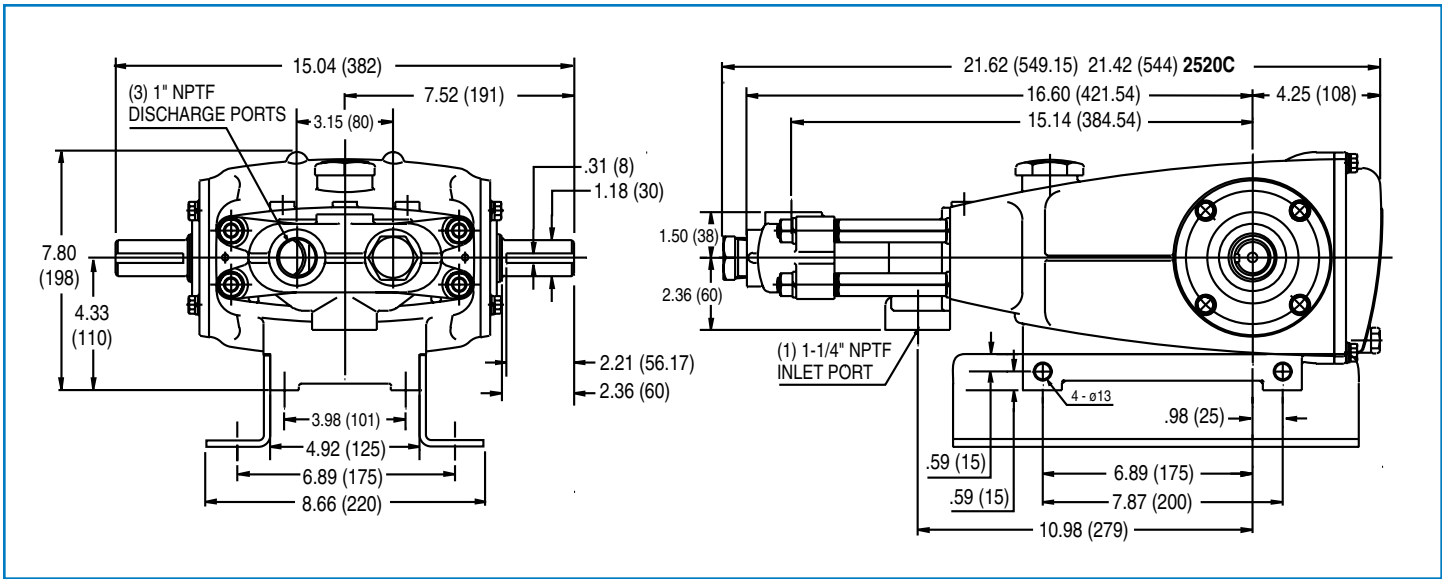

Models 1520, 1521, 1525, 2520, 2521, 2525, 2520C

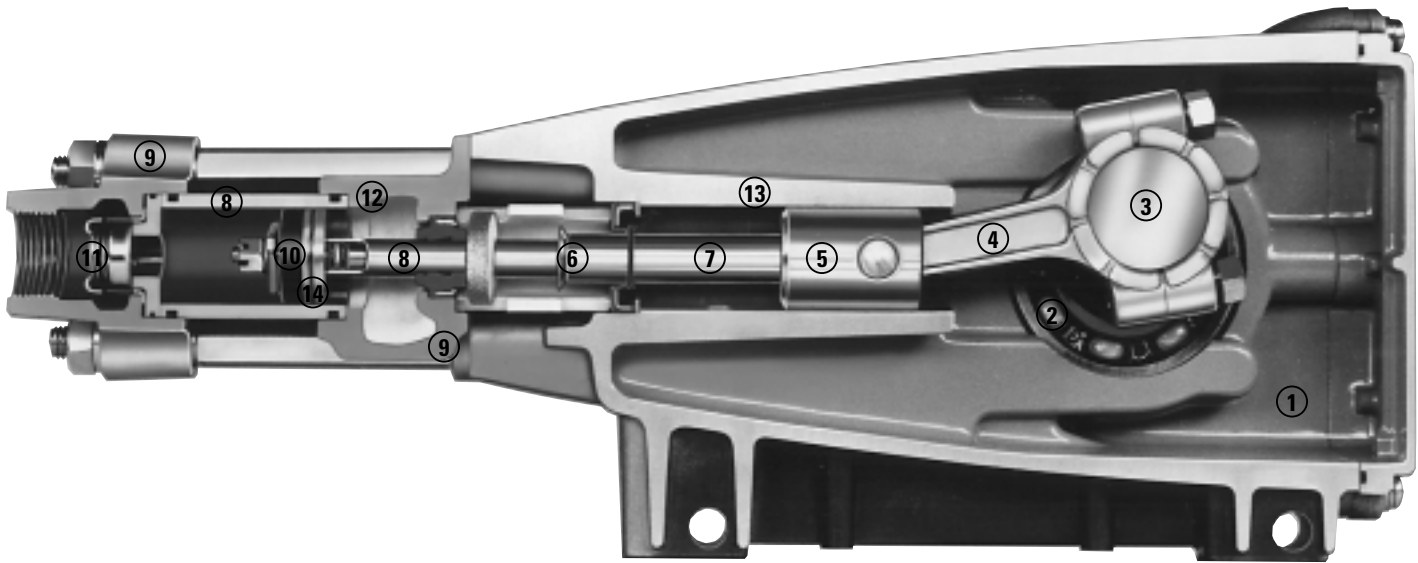

- 1 Die cast aluminum **crankcase** means high strength, lightweight, and excellent tolerance control.
- 2 Oversized crankshaft **bearings** provide extended bearing life and pump performance.
- 3 Chrome-moly **crankshaft** provides unmatched strength and surface hardness for long life.
- 4 Matched oversized high strength **connecting rods** are noted for superior strength and bearing quality.
- 5 The **piston rods** are high tensile strength 304 stainless steel with Zamak crossheads.
- 6 The stainless steel **slinger** provides back-up protection for the crankcase seal, keeping pumped liquids out of the crankcase.
- 7 The patented **stepped piston rod** with hard chrome-plated stainless steel **sleeve** provides a durable wear surface and easy wet end servicing.
- 8 The **cylinder** and **sleeve** wear surfaces are hard chrome-plated 304 stainless steel for longer service life.
- 9 **Manifolds** are of high tensile strength chrome-plated brass or 316 stainless steel for special corrosion resistance.
- 10 100% wet **cup/seal** design adds to service life by allowing pumped liquids to cool and lubricate the elastomers on both sides.
- 11 304 stainless steel **valves, seats, and springs** provide corrosion-resistance, positive seating and long life.
- 12 Special **dual inlet seals** with cooling ports allow pumped liquids up to 210°F.
- 13 **Crossheads** are 360° supported for uncompromising alignment.
- 14 Mechanically actuated **inlet valves** provide strong lift and easy prime.

World Headquarters

CAT PUMPS

1681 - 94th Lane N.E. Minneapolis, MN 55449-4324

Phone (763) 780-5440 — FAX (763) 780-2958

e-mail: techsupport@catpumps.com

www.catpumps.com

International Inquiries

FAX (763) 785-4329

e-mail: intlsales@catpumps.com



The Pumps with Nine Lives

CAT PUMPS (U.K.) LTD.

1 Fleet Business Park, Sandy Lane, Church Crookham

FLEET, Hampshire, GU52 8BF, England

Phone Fleet 44 1252-622031 — Fax 44 1252-626655

e-mail: sales@catpumps.co.uk

N.V. CAT PUMPS INTERNATIONAL S.A.

Heiveldekens 6A, B-2550 Kontich, Belgium

Phone 32-3-450.71.50 — Fax 32-3-450.71.51

e-mail: cpi@catpumps.be www.catpumps.be

CAT PUMPS DEUTSCHLAND GmbH

Buchwiese 2, D-65510 Idstein, Germany

Phone 49 6126-9303 0 — Fax 49 6126-9303 33

e-mail: catpumps@t-online.de www.catpumps.de