

15 Frame Plunger Pump

316 Stainless Steel Model

1951

Patented Design Specifically for Liquid Carbon Dioxide

FEATURES

Superior Design

- Triplex Plunger design gives smoother liquid flow.
- Plunger seals are lubricated by the liquid being pumped.
- Requires no additional seal flushing liquids.
- High pressure inlet capability.
- Specifically configured pump head ensures that pumped liquid is maintained in a liquid state, even when pumping close to the vapor curve. Internal head design minimizes inefficiencies due to liquid compressibility (patent applied for.)
- Reduces the need for a primary (booster) pump or a subcooler.
- Oil bath crankcase assures optimum lubrication.
- Close tolerance concentricity of the ceramic plungers maximizes seal life.

Quality Materials

- 316SSL Block-style manifold for liquid and process compatibility, strength and corrosion resistance.
- Special concentric, high density, polished solid ceramic plungers provide a true wear surface and extended seal life.
- Elastomers selected to minimize the effects of vapor absorption.
- Die cast aluminum crankcase provides high strength, minimum weight and precision tolerance control.
- Chrome-moly crankshaft gives unmatched strength and surface hardness.
- Oversized crankshaft bearings with greater loading capacity mean longer bearing life.

Easy Maintenance

- Head is easily serviced without dismantling crankcase, requiring less time and effort.
- Quick-disconnect weld pipe connections enable the head to be removed quickly and easily without disturbing insulated pipework.
- Valve assemblies are accessible without disturbing piping, for quick service.

SPECIFICATIONS

	U.S. Measure	Metric Measure
Flow	5 GPM	(19 L/M)
Pressure Range.....	100 to 1450 PSI	(7 to 100 BAR)
RPM	480 RPM	(480 RPM)
Inlet Pressure Range	-5 to 500 PSI	(-0.35 to 35 BAR)
Bore.....	0.945"	(24 mm)
Stroke.....	1.180"	(30 mm)
Crankcase Capacity	42 oz.	(4 L)
Liquid Temperature Range.....	-22 to 160°F	(-30 to 71°C)
Inlet Ports (2)	Butt Weld Flange	(Butt Weld Flange)
Discharge Port (2).....	Butt Weld Flange	(Butt Weld Flange)
Pulley Mounting	Either Side	(Either Side)
Shaft Diameter	1.180"	(30 mm)
Weight.....	71 lbs.	(32 kg)
Dimensions.....	16.37 x 12.99 x 6.69"	(416 x 330 x 170 mm)

Contact CAT PUMPS with your liquid CO₂ requirements.

NOTE: Before dismantling pump for service, allow gas to escape by leaving pump to stabilize at atmospheric pressure for some considerable time.

⚠ WARNING

All systems require both a primary pressure regulating device (i.e., regulator, unloader) and a secondary pressure safety relief device (i.e., pop-off valve, safety valve). Failure to install such relief devices could result in personal injury or damage to the pump or to system components. CAT PUMPS does not assume any liability or responsibility for the operation of a customer's high pressure system.

“Customer confidence is our greatest asset”

PARTS LIST

ITEM	P/N	MATL	DESCRIPTION	QTY
2	50146	STL	Key (M7x7x40) (Not Shown)	1
5	700957	S	Screw, Sems (M6 x 16)	8
	700960	S	Washer (M6)	8
	15849	S	Lockwasher (M6)	8
8	43496	AL	Case, Bearing	2
9	815281	FBR	Shim, Split, 2-Pc	0-6
10	11340	NBR	O-Ring, Bearing Cover - 70D	2
11	43495	NBR	Seal, Oil, Crankshaft - 70D	2
15	39060	STL	Bearing	2
20	48600	TNM	Rod, Connecting Assembly	3
25	43494	FCM	Crankshaft, Dual-End, (M30)	1
32	43211	ABS	Cap, Oil Filler	1
33	14177	NBR	O-Ring, Filler Cap - 70D	1
37	92241	—	Gauge, Oil, Bubble w/Gasket - 80D	1
38	44428	NBR	Gasket, Flat, Oil Gauge - 80D	1
40	700956	S	Screw, Sems (M6x20)	4
	700960	S	Washer (M6)	4
	15849	S	Lockwasher (M6)	4
48	25625	STCP	Plug, Drain (1/4"x19BSP)	1
49	23170	NBR	O-Ring, Drain Plug - 70D	1
50	43491	AL	Cover, Rear	1
51	44834	NBR	O-Ring, Rear Cover - 70D	1
52	702867	FBR	Gasket, Insulating	1
53	115471	AL	Crankcase	1
54	27488	S	Pin, Guide	2
64	43507	CM	Pin, Crosshead	3
65	43501	SZZ	Rod, Plunger	3
69	126592	STCP R	Washer, Oil Seal	3
70	43500	NBR	Seal, Oil, Crankcase - 80D	3
75	43506	S	Slinger, Barrier	3
88	45675	S	Washer, Keyhole	3
89	45879	SS	Spacer, Plunger	3
90	43552	CC	Plunger, Ceramic (M24x77)	3
95	43236	STZP	Stud, Retainer (M6x16)	3
96	43235	PTFE	Back-up Ring, Plunger Retainer	3
97	17399	NBR	O-Ring, Plunger Retainer - 80D	3
98	44041	SS	Gasket, Plunger Retainer	3
99	44031	SS	Retainer, Plunger (M6)	3
100	702881	D	Retainer, seal (Anti-icing)	3
106	702680	SFTB	Seal, Low Pressure	3
110	702457	SS	Plate, Seal Support	1
117	87951	S	Screw, HSH (M10x30)	8
118	702869	SS	Screw, HSH (M6x10)	3
119	702880	STL/NBR	Seal Washer	3
120	702459	SS	Case, Low Pressure Seal	3
121	33333	NBR	O-Ring, Spacer - 90D	3
122	48363	D	Back-up Ring, Spacer	3
125	702680	SFTB	Seal, High Pressure	3
163	702450	NBR	O-Ring, Seat - 90D	6
164	702460	SSL	Seat	6
166	43721	S	Valve	6
167	43751	S	Spring	6
168	44564	PVDF	Retainer, Spring	6
172	702660	PTFE	Washer, Seal	6
174	702458	SS	Plug, Valve	6
185	702456	SSL	Manifold, Inlet / Discharge	1
187	44005	S	Stud, Manifold (M10 x 45)	4
192	15847	S	Lockwasher (M10)	4
194	81258	S	Nut, Hex (M10)	4
250	30764	NY	Protector, Shaft w/2 Screws	1
260	30613	STZP	Rail, Angle Assy	1
300	702362	NBR	Kit, Seal (Incls: 96, 97, 106, 121, 122, 125, 401, 404)	1
301	702483	SS	Ring, Flange (Discharge)	1-2
302	702479	SS	Ring, Flange (Inlet)	1-2
303	701240	SSS	Screw, HSH (M8x16)	0-7
305	702481	SS	Plate, Blank (Inlet Port)	0-1
306	702485	SS	Plate, Blank (Discharge Port)	0-1
307	703032	SS	Screw, HSH (M8x40)	7-14

EXPLODED VIEW

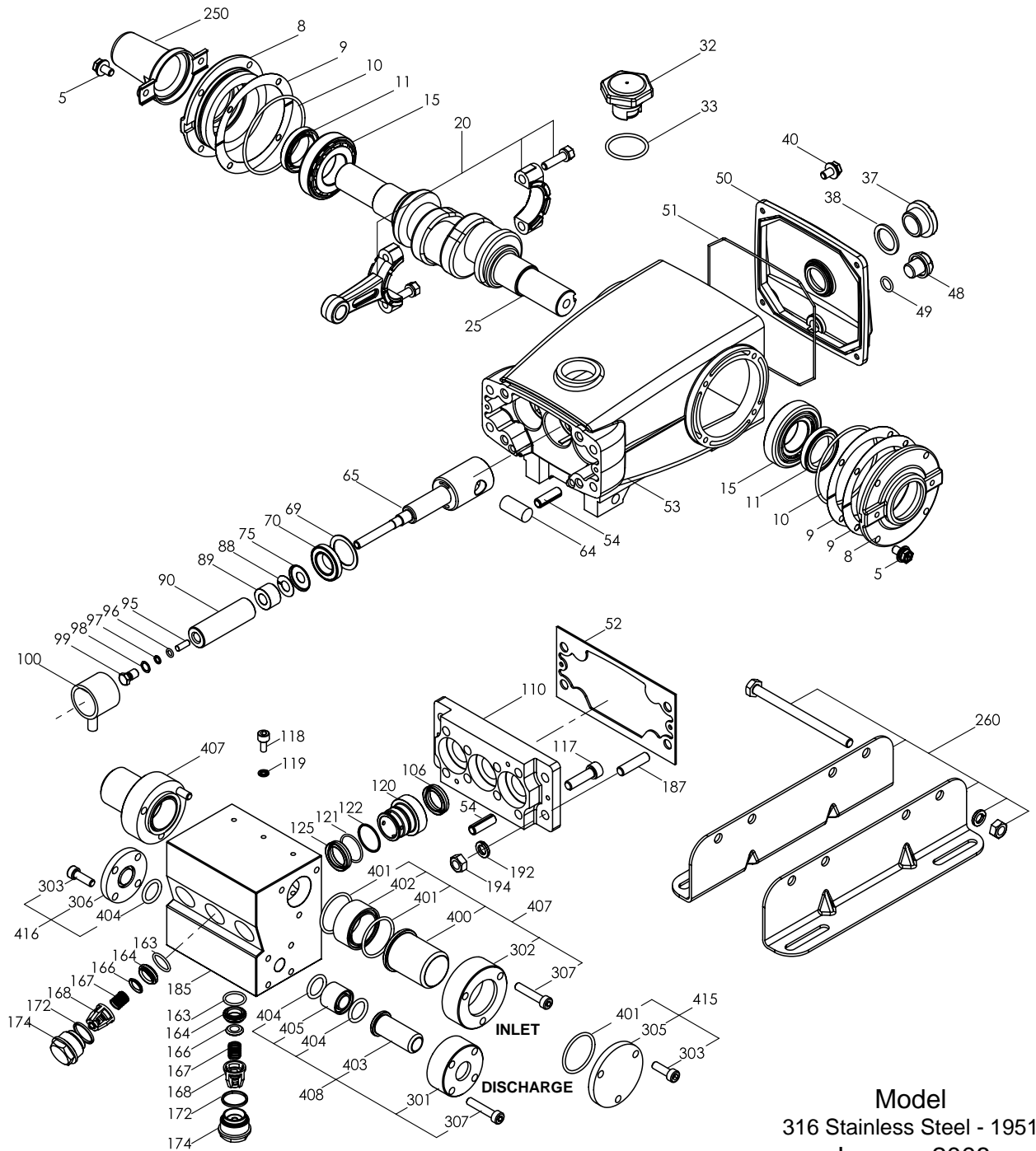

Model
316 Stainless Steel - 1951
January 2008

310	702360	NBR	Kit, Valve (Incls: 163, 164, 166, 167, 168, 172)	2
400	702480	SS	Pipe, Inlet (Weld Prep)	2
401	702663	NBR	O-Ring, Inlet Flange - 90D	3-4
402	702478	SS	Spacer, Face Seal (Inlet Flange)	2
403	702484	SS	Pipe, Discharge (Weld Prep)	1-2
404	702664	NBR	O-Ring, Discharge Flange - 90D	3-4
405	702482	SS	Spacer, Face Seal (Discharge Flange)	1-2
407	702661	SS	Assembly, Inlet Flange (Incls: 302, 307, 400, 401, 402)	1-2
408	702662	SS	Assembly, Discharge Flange (Incls: 301, 307, 403, 404, 405)	1-2
415	702671	SS	Assembly, Inlet Port Blank (Incls: 303, 305, 401)	1
416	702672	SS	Assembly, Discharge Port Blank (Incls: 303, 306, 404)	1

Italics are optional items. R Components comply with RoHS Directive.

MATERIAL CODES (Not Part of Part Number): ABS=ABS Plastic AL=Aluminum CC=Ceramic CM=Chrome-moly D=Acetal
FBR=Fiber FCM=Forged Chrome-Moly NBR=Medium Nitrile (Buna-N) NY=Nylon POP=Polypropylene PTFE=Pure Polytetrafluoroethylene
PVDF=Polyvinylidene Fluoride S=304SS SFTB=Special Blend PTFE SS=316SS SSL=316SS/Low Carbon STCP=Steel/Chrome Plated
STL=Steel STZP=Steel/Zinc Plated SZZ=304SS/Zamak TNM=Special High Strength

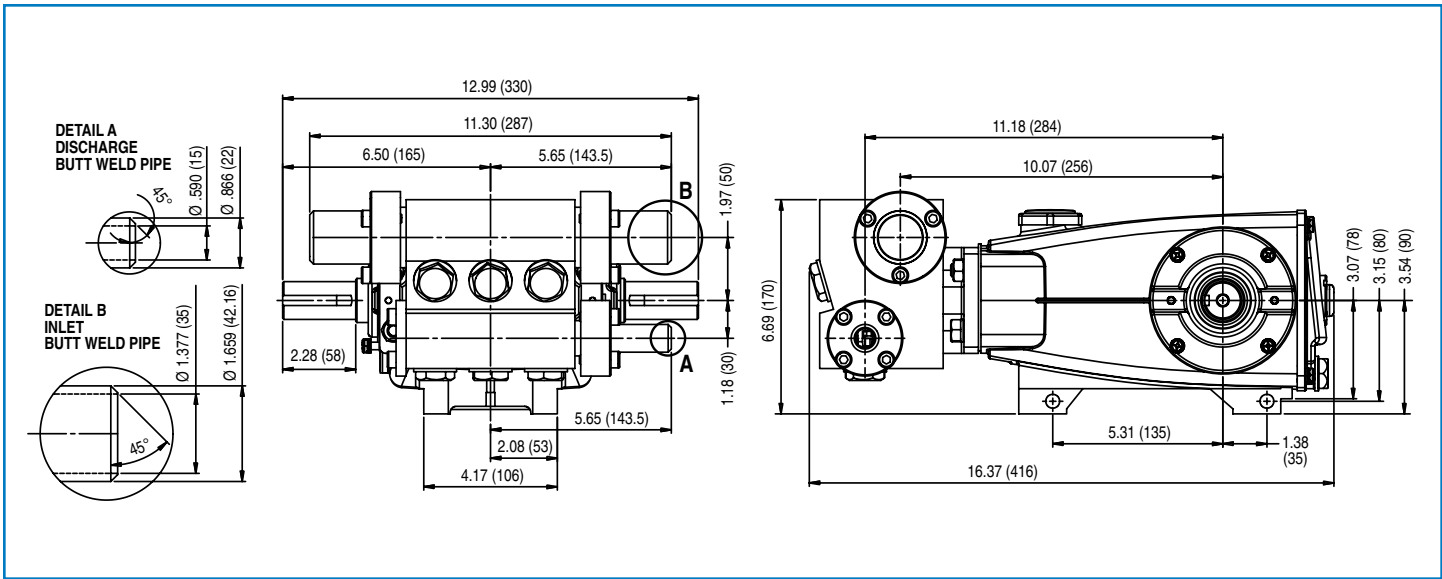

Model 1951

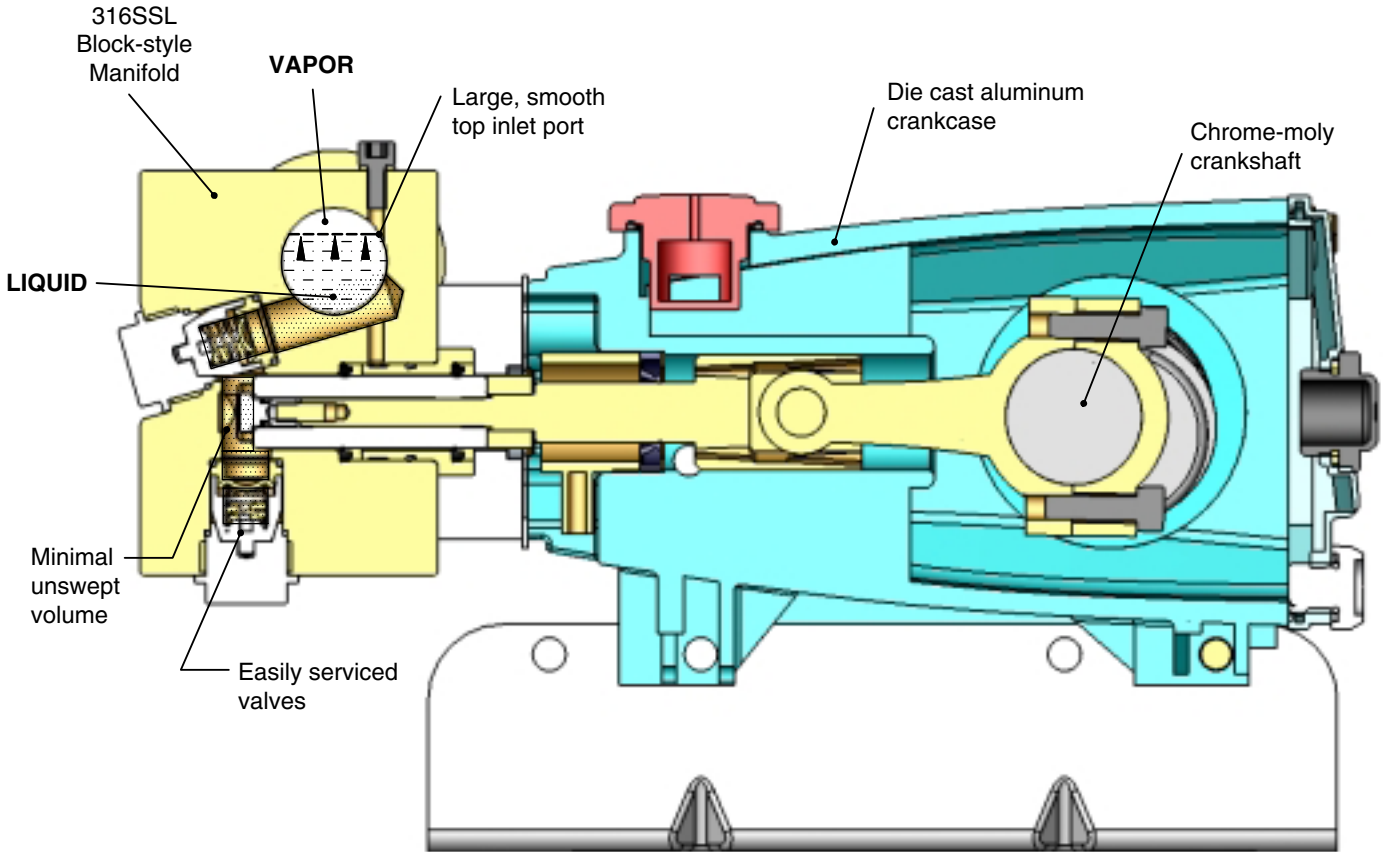

World Headquarters
CAT PUMPS
 1681 - 94th Lane N.E. Minneapolis, MN 55449-4324
 Phone (763) 780-5440 — FAX (763) 780-2958
 e-mail: techsupport@catpumps.com
 www.catpumps.com

International Inquiries
 FAX (763) 785-4329
 e-mail: intlsales@catpumps.com



CAT PUMPS (U.K.) LTD.
 1 Fleet Business Park, Sandy Lane, Church Crookham
 FLEET, Hampshire, GU52 8BF, England
 Phone Fleet 44 1252-622031 — Fax 44 1252-626655
 e-mail: sales@catpumps.co.uk

N.V. CAT PUMPS INTERNATIONAL S.A.
 Heiveldekens 6A, B-2550 Kontich, Belgium
 Phone 32-3-450.71.50 — Fax 32-3-450.71.51
 e-mail: cpi@catpumps.be www.catpumps.be

CAT PUMPS DEUTSCHLAND GmbH
 Buchwiese 2, D-65510 Idstein, Germany
 Phone 49 6126-9303 0 — Fax 49 6126-9303 33
 e-mail: catpumps@t-online.de www.catpumps.de

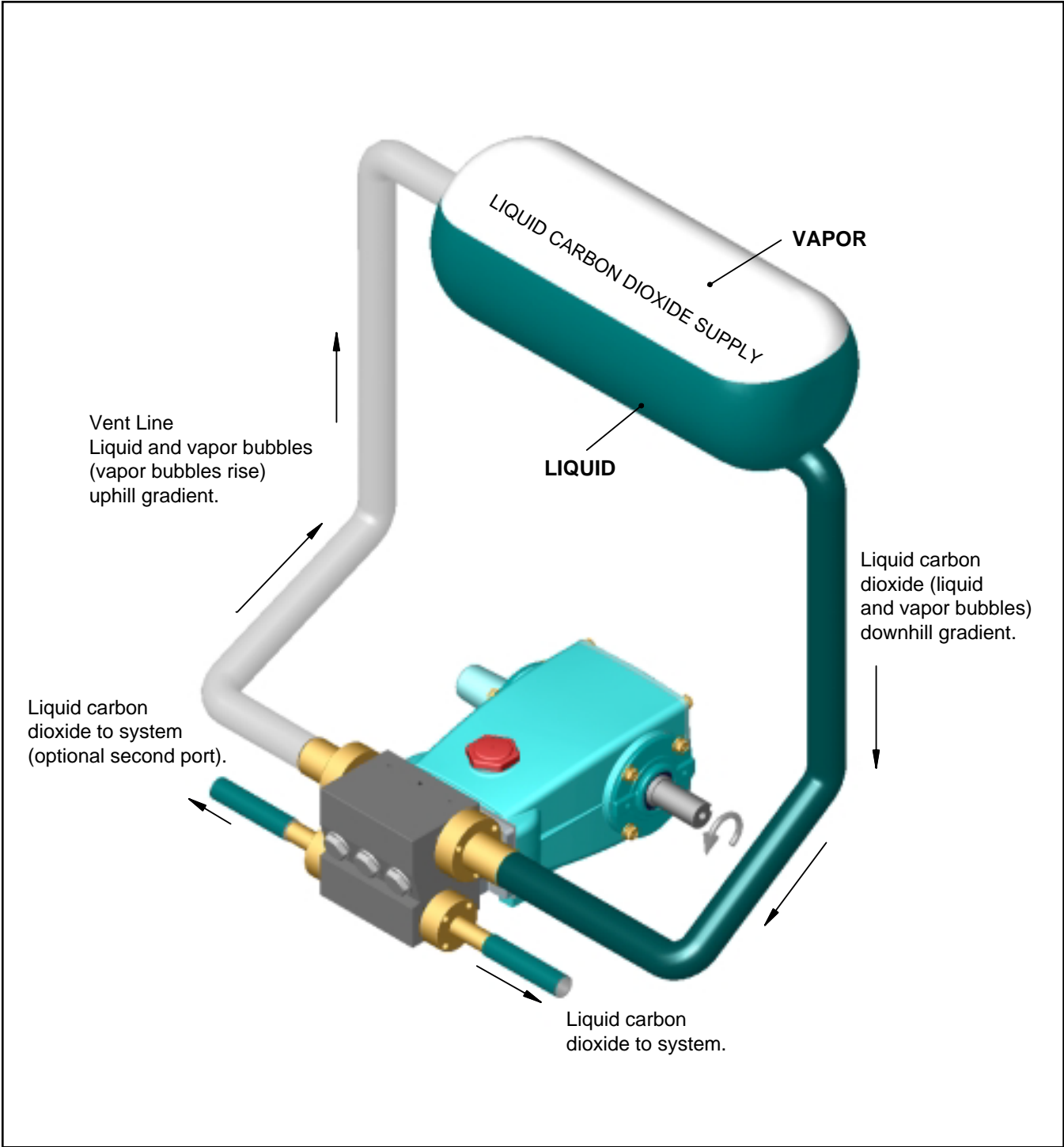

**SCHEMATIC INSTALLATION DIAGRAM
"VENTED INLET"**

CO₂ VAPOR PRESSURE

