

Model 1DX03ELS.MIST Shown

Electric motor sold separately.

Direct-Drive Misting Plunger Pumps

Models 1DX03ELS.MIST
1DX015ELS.MIST

FEATURES

- Single or dual plunger design provides a smooth liquid flow.
- Specially formulated Hi-Pressure Seals and concentrically ground ceramic plungers assure maximum seal life.
- Stacked Stainless steel valve design for long life and easy servicing.
- Ultra compact, direct-drive low speed unit for quiet operation.
- Integral Regulator with built-in by-pass to assure system pressure control and pump protection.

⚠ WARNING

All systems require both a primary pressure regulating device (i.e., regulator, unloader) and a secondary pressure safety relief device (i.e., pop-off valve, safety valve). Failure to install such relief devices could result in personal injury or damage to the pump or to system components. CAT PUMPS does not assume any liability or responsibility for the operation of a customer's high pressure system.

SPECIFICATIONS

U.S. Measure

Metric Measure

MODEL 1DX03ELS.MIST

Flow.....0.3 GPM (1.14 L/M)
Maximum Discharge Pressure1200 PSI (85 BAR)
Stroke (Dual Plunger)0.078" (2.0 mm)

MODEL 1DX015ELS.MIST

Flow.....0.15 GPM (0.57 L/M)
Maximum Discharge Pressure1200 PSI (85 BAR)
Stroke (Single Plunger)0.078" (2.0 mm)

COMMON SPECIFICATIONS

Maximum RPM.....1725 RPM (1725 RPM)
Inlet Pressure RangeFlooded to 60 PSI (Flooded to 4 Bar)
Bore.....0.630" (16 mm)
Crankcase Capacity8.5 oz. (0.25 L)
Maximum Liquid Temperature140°F (60°C)
Above 130°F call CAT PUMPS for inlet conditions and elastomer recommendations.
Inlet Ports (1)3/8" NPTF (3/8" NPTF)
Discharge Port (1).....3/8" NPTM (3/8" NPTM)
Shaft Diameter5/8" Hollow (15.8 mm Hollow)
Weight.....10.7 lbs. (4.9 kg)
Dimensions.....7.99 x 7.75 x 6.29" (203 x 197 x 160 mm)

ELECTRIC HORSEPOWER REQUIREMENTS

MODEL	FLOW		PRESSURE		RPM
	U.S. GPM	L/M	PSI	PSI	
			1000	1200	
		BAR	BAR		
1DX03ELS.MIST	0.3	1.14	0.20	0.24	1725
1DX015ELS.MIST	0.15	0.57	0.10	0.12	1725

DETERMINING THE PUMP R.P.M. $\frac{\text{Rated G.P.M.}}{\text{Rated R.P.M.}} = \frac{\text{"Desired" G.P.M.}}{\text{"Desired" R.P.M.}}$

DETERMINING THE REQUIRED H.P. $\frac{\text{GPM x PSI}}{1460} = \text{Electric Brake H. P. Required}$

DETERMINING MOTOR PULLEY SIZE $\frac{\text{Motor Pulley O.D.}}{\text{Pump R.P.M.}} = \frac{\text{Pump Pulley O.D.}}{\text{Motor R.P.M.}}$

Refer to pump **Service Manual** for repair procedure, additional technical information and **pump warranty**.

"Customer confidence is our greatest asset"

EXPLODED VIEW

October 2007

PLUNGER PUMP MODELS

1DX03ELS.MIST, 1DX015ELS.MIST

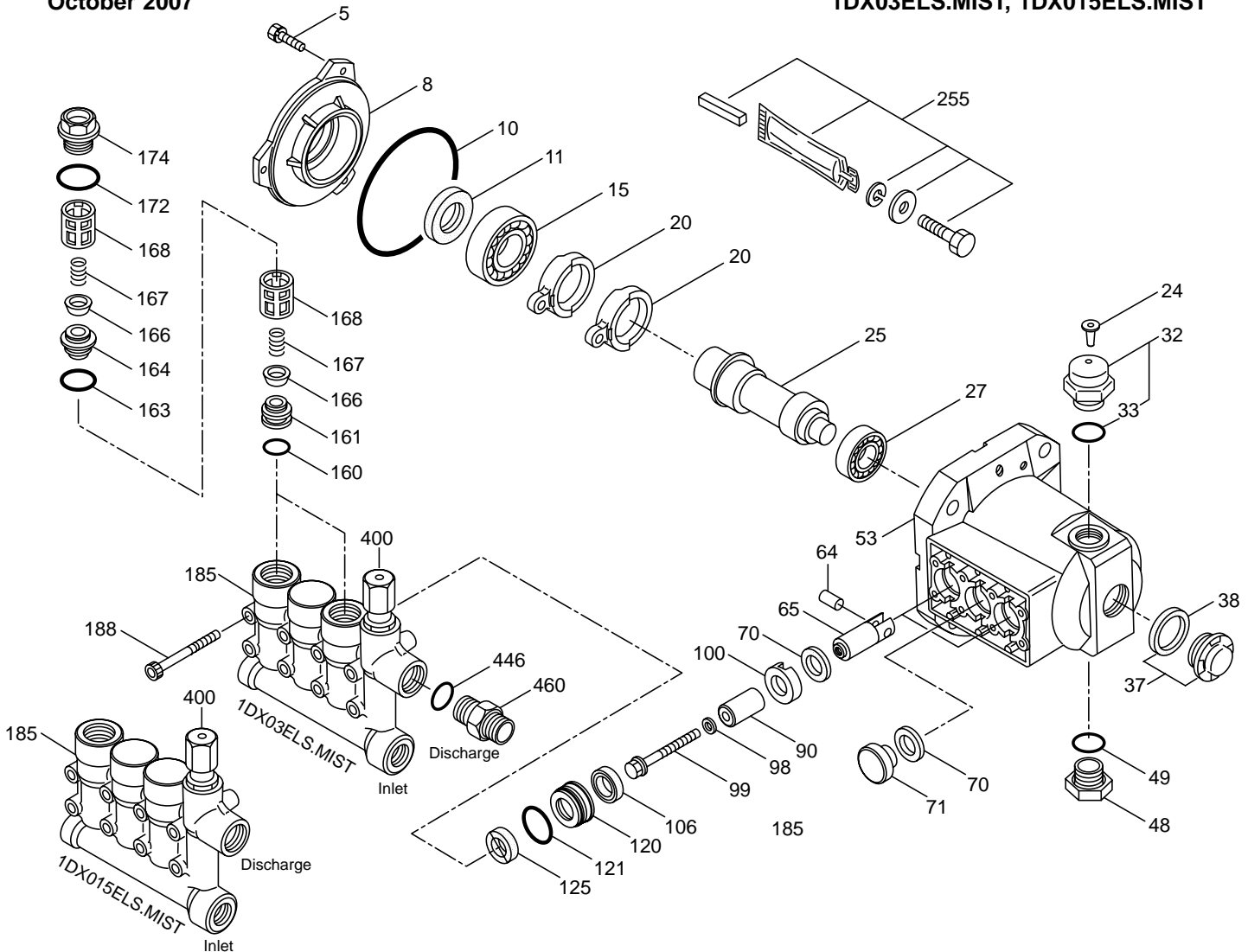

PARTS LIST

ITEM	P/N	MATL	DESCRIPTION	QTY	ITEM	P/N	MATL	DESCRIPTION	QTY
5	547161	STCP	Screw, HH (M6x14)	3	125	46240	NBR	Seal, HPS w/S	2/1
	<i>549360</i>	<i>STCP R</i>	<i>Screw, HH (M6x14)</i>	<i>3</i>	160	13965	NBR	O-Ring, Inlet Valve Seat - 70D	2/1
8	547153	AL	Cover, Bearing	1	161	545177	S	Seat, Inlet	2/1
10	14041	NBR	O-Ring, Bearing Cover - 70D	1	163	19285	NBR	O-Ring, Seat - 70D	2/1
11	55337	NBR	Seal, Oil - 70D	1	164	545178	S	Seat, Discharge	2/1
15	14488	STL	Bearing, Ball	1	166	46764	S	Valve	4/2
20	547048	TNM	Rod, Connecting	2/1	167	46865	S	Spring	4/2
24	76045	LDPE	Plug, Oil Cap (Remove Before Startup)	1	168	543988	PVDF	Retainer, Spring	4/2
25	548879	CM	Crankshaft, 1725 RPM, 5/8", 2.0 mm	1	172	142807	NBR	O-Ring, Plug - 90D	2/1
27	13832	STL	Bearing, Ball	1	174	46759	BB	Plug, Valve (M20x1.5)	2/1
32	547961	RTP	Cap, Oil Filler w/O-Ring	1	185	548882	BB	Head, Manifold w/Modular Reg. Body (03ELS)	1
33	14179	NBR	O-Ring, Oil Filler Cap - 70D	1		549002	BB	Head, Manifold w/Modular Reg. Body (015ELS)	1
37	92241	—	Gauge, Bubble Oil w/Gasket - 80D	1	188	542406	STZP	Screw, HSH (M6x60)	8
38	44428	NBR	Gasket, Flat Flex, Oil Gauge - 80D	1		<i>549357</i>	<i>STCP R</i>	<i>Screw, HSH (M6x60)</i>	<i>8</i>
48	44842	NY	Plug, Drain	1	255	30516	STZP	Assy, Bolt Mount	1
49	14179	NBR	O-Ring, Drain Plug - 70D	1		126543	STCP R	Screw, HH (3/8"-16UNCx1-3/8")	4
53	542407	AL	Crankcase	1		30980	STZP R	Washer, Flat (3/8")	4
64	46229	CM	Pin, Crosshead	2/1		30921	STZP R	Lockwasher (3/8")	4
65	542402	BBCP	Rod, Plunger	2/1		6106	—	Lubricant, Antiseize	1
70	47215	NBR	Seal, Oil - 70D	3		34050	STL	Key (3/16x3/16x27 HD)	1
71	548331	BB	Retainer, Oil Seal	1/2	283	990394	—	<i>Kit, Oil Drain (Not Shown)</i>	<i>1</i>
90	542403	CC	Plunger (M16x27)	2/1	300	76054	NBR	<i>Kit, Seal (Incls: 98,106,121,125) (03ELS)</i>	<i>1</i>
98	46730	NBR	Washer, Seal - 90D	2/1		76053	NBR	<i>Kit, Seal (Incls: 98,106,121,125) (015ELS)</i>	<i>1</i>
99	542405	S	Retainer, Plunger (M6x35)	2/1	310	76058	NBR	<i>Kit, Valve (Incls: 160,161,163,164,166,167,168,172) (03ELS)</i>	<i>1</i>
100	46233	NY	Retainer, Seal	2/1		76057	NBR	<i>Kit, Valve (Incls: 160,161,163,164,166,167,168,172) (015ELS)</i>	<i>1</i>
106	48222	NBR	Seal, LPS w/S-Spg - 85D	2/1	400	—	—	Regulator, Modular (See Indiv. Parts)	1
120	547357	BB	Case, Seal	2/1	446	13969	NBR	O-Ring, Discharge Fitting - 70D	1
121	13976	NBR	O-Ring, Seal Case - 70D	2/1	460	107681	BB	Fitting, Discharge (3/8" NPTM)	1

Italics are optional items. See Tech Bulletins 002, 024, 036, 043, 055, 074 and 083 for additional information. R Components comply with RoHS Directive.

MATERIAL CODES (Not Part of Part Number): AL=Aluminum BB=Brass BBCP=Brass/Chrome Plated CC=Ceramic CM=Chrome-moly LDPE=Low Density Polyethylene NBR=Medium Nitrile (Buna-N) NY=Nylon PVDF=Polyvinylidene Fluoride RTP=Reinforced Composite S=304SS STL=Steel STCP=Steel/Chrome Plated STZP=Steel/Zinc Plated TNM=Special High Strength

NOTE: Discard Key which may come standard with most motors and **use only the key included in this kit.**

INTEGRAL REGULATOR EXPLODED VIEW

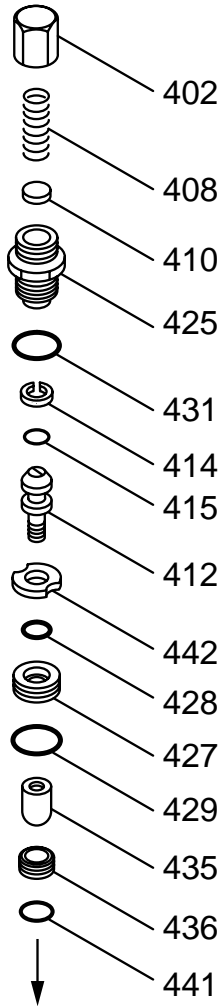

PARTS LIST

ITEM	PN	MATL	DESCRIPTION	QTY.
402	46570	BB	Cap, Adjusting	1
408	46433	STZP	Spring, Pressure	1
	549924	STCP R	Spring, Pressure	1
410	549352	STCP R	Retainer, Spring	1
412	46251	BB	Stem, Piston	1
—	548229	BB	Assy, Piston	1
414	28338	PTFE	Back-up-Ring, Piston Stem	1
415	22056	NBR	O-Ring, Piston Stem - 70D	1
425	46248	BB	Retainer, Piston	1
427	46249	BB	Retainer, Valve	1
428	17399	NBR	O-Ring, Valve Retainer (Inner) - 80D	1
429	13966	NBR	O-Ring, Valve Retainer (Outer) - 70D	1
431	13969	NBR	O-Ring, Piston Retainer - 70D	1
435	548193	S	Valve	1
436	46253	S	Seat	1
441	13963	NBR	O-Ring, Seat - 70D	1
442	46250	S	Washer	1
468	33099	NBR	Kit, O-Ring (Incls: 414,415,428,429,431,441)	1
—	31088	NBR	Kit, Repair (Incls: 412,431,436,441)	1

Italics are optional items. R Components comply with RoHS Directive.

MATERIAL CODES (Not Part of Part Number):

BB=Brass NBR=Medium Nitrile (Buna-N) PTFE=Pure Polytetrafluoroethylene
S=304SS STCP=Steel/Chrome Plated STZP=Steel/Zinc Plated

SPECIFICATIONS

	U.S. Measure	Metric Measure
GPM.....	0.3 GPM	(1.14 L/M)
PSI Range.....	100-1200 PSI	(7-85 BAR)
Discharge Port	3/8" NPTM	(3/8" NPTM)

INSTALLATION

An integral Regulator comes with each .MIST pump to provide system pressure regulation and pump protection.

OPERATION

Set the Regulator while the high pressure system is turned on. Adjust the Adjusting Cap in small increments until the desired system pressure is reached. Install a pressure gauge close to the manifold head of the pump to check pressure during start-up and periodically to monitor system performance.

System should be **purged of air before operation**. System liquid must flow through the pump without discharge restriction to assure full system pressure is reached.

SERVICE

The Regulator should be serviced on the same schedule as the seals in the pump.

1. Remove hex Adjusting Cap, Spring and Spring Retainer.
2. Using a socket or wrench, remove Piston Retainer from the unloader body.

NOTE: Loctite® 242® is used in the assembly process.

3. Using a needle nose pliers, pull the complete assembly, Piston Stem through Valve from the unloader body.
4. Using caution, grasp the Valve with a pliers near the top next to the Valve Retainer and unthread the Piston Stem using a flat head screwdriver.
5. Remove o-rings from Valve Retainer, and back-up-ring and o-ring from Piston Stem. Examine o-rings and back-up-ring for cuts or wear and replace as needed.
6. Examine the Valve, Valve Retainer and Piston Stem for wear and replace as needed.

NOTE: The seat will be damaged during removal and must be replaced.

7. Replace seat and stem from Repair Kit.
8. Lubricate all o-rings for ease of installation and install on Seat, Piston Retainer, Valve Retainer and Piston Stem.
9. Assemble the Washer, Valve Retainer with o-rings and Valve onto the Piston Stem with o-ring and back-up-ring and thread together hand tight. Press complete assembly into body until completely seated.
10. Apply Loctite® 242® to threads of Piston Retainer with o-ring. Thread into body and tighten using a wrench.
11. Insert Spring Retainer and Spring into the body.
12. Thread the Adjusting Cap into the body and set for system pressure.

NOTE: If unit is infrequently used or periodically stored, o-rings may become dry and will need to be replaced.

CAUTION

This pump has an internally by-passed Regulator and if the pump is operated with no flow out the nozzles (100% by-pass), heat damage will occur to the seals and valve retainers in a short period of time.

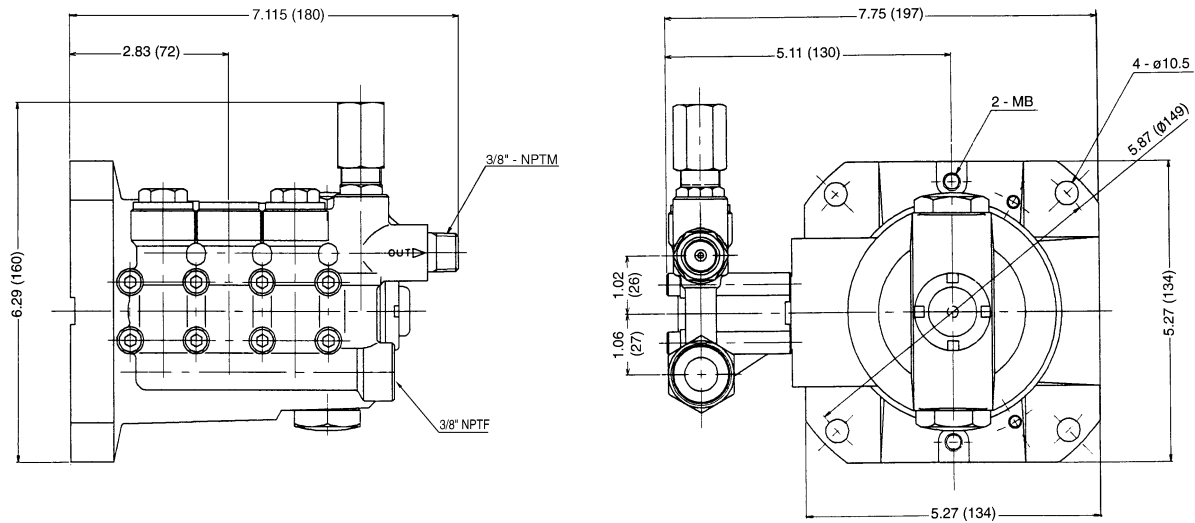

Models 1DX03ELS.MIST, 1DX015ELS.MIST

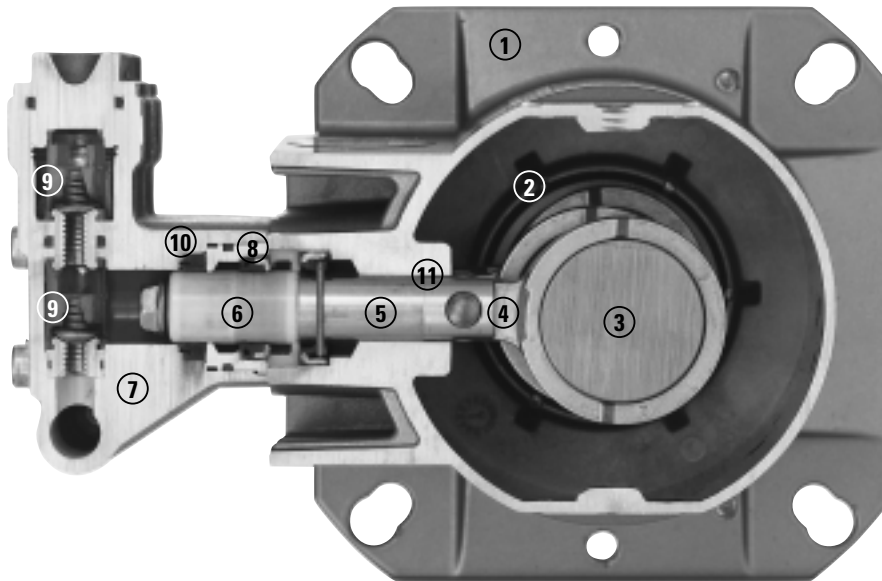

- | | | |
|--------------------------------------------------------------------------------------------------------------------------------------------------------------------------------------------------------------------------------------------------------------------------------------------------------------------------------------------------------------------------------------------------------------|-----------------------------------------------------------------------------------------------------------------------------------------------------------------------------------------------------------------------------------------------------------------------------------------------------------------------------------------------------------------------------------------------------------------------------------------------------------------------------------------------------------------|-------------------------------------------------------------------------------------------------------------------------------------------------------------------------------------------------------------------------------------------------------------------------------------------------------------------------------|
| <p>1 Die cast flange-style aluminum crankcase means high strength, lightweight, and excellent tolerance control.</p> <p>2 Heavy-duty dual crankshaft bearings provide extended drive-end life.</p> <p>3 Chrome-moly crankshaft provides unmatched strength and surface hardness for long life.</p> <p>4 High strength connecting rods assure durability and bearing quality.</p> | <p>5 Strong chrome plated brass plunger rods with chrom-moly crosshead pins.</p> <p>6 Special, concentric, high-density, polished solid ceramic plungers provide a true wear surface and extended seal life.</p> <p>7 High tensile strength, forged brass manifold head with built-in integral regulator and eight mounting screws for exceptional strength.</p> <p>8 100% wet seal design adds to service life by allowing pumped liquids to cool and lubricate on both sides.</p> | <p>9 Stainless steel valves, seats and springs provide corrosion-resistance, ultimate seating and extended life.</p> <p>10 Unique design and specially formulated Hi-Pressure Seals offer unmatched performance and seal life.</p> <p>11 Crossheads are 360° supported for uncompromising alignment.</p> |
|--------------------------------------------------------------------------------------------------------------------------------------------------------------------------------------------------------------------------------------------------------------------------------------------------------------------------------------------------------------------------------------------------------------|-----------------------------------------------------------------------------------------------------------------------------------------------------------------------------------------------------------------------------------------------------------------------------------------------------------------------------------------------------------------------------------------------------------------------------------------------------------------------------------------------------------------|-------------------------------------------------------------------------------------------------------------------------------------------------------------------------------------------------------------------------------------------------------------------------------------------------------------------------------|

World Headquarters

CAT PUMPS

1681 - 94th Lane N.E. Minneapolis, MN 55449-4324

Phone (763) 780-5440 — FAX (763) 780-2958

e-mail: techsupport@catpumps.com

www.catpumps.com

International Inquiries

FAX (763) 785-4329

e-mail: intlsales@catpumps.com



The Pumps with Nine Lives

CAT PUMPS (U.K.) LTD.

1 Fleet Business Park, Sandy Lane, Church Crookham

FLEET, Hampshire, GU52 8BF, England

Phone Fleet 44 1252-622031 — Fax 44 1252-626655

e-mail: sales@catpumps.co.uk

N.V. CAT PUMPS INTERNATIONAL S.A.

Heiveldekens 6A, B-2550 Kontich, Belgium

Phone 32-3-450.71.50 — Fax 32-3-450.71.51

e-mail: cpi@catpumps.be www.catpumps.be

CAT PUMPS DEUTSCHLAND GmbH

Buchwiese 2, D-65510 Idstein, Germany

Phone 49 6126-9303 0 — Fax 49 6126-9303 33

e-mail: catpumps@t-online.de www.catpumps.de