



# 3 Frame Plunger Pump Models 230 240, 270

## FEATURES

### Superior Design

- Triplex plunger design provides smoother liquid flow.
- Hi-Pressure Seals are completely lubricated and cooled by the liquid being pumped.
- Inlet and discharge valve assemblies interchange for easier maintenance.
- Lubricated Lo-Pressure Seals provide double protection against external leakage.
- Oil bath crankcase assures optimum lubrication.
- Close tolerance concentricity of the ceramic plunger maximizes seal life.
- Optional Belt Drive or Motorized versions offer system flexibility.

### Quality Materials

- Precision design 304 stainless steel valves and seats are hardened and polished for ultimate seating and extended valve life.
- Brass manifold is strong and corrosion resistant.
- Special concentric, high-density, polished, solid ceramic plungers provide a true wear surface and extended seal life.
- Specially formulated, CAT PUMP exclusive, Hi-Pressure Seals offer unmatched performance and seal life.
- Die cast aluminum crankcase provides high strength, minimum weight and precision tolerance control.
- Chrome-moly crankshaft gives unmatched strength and surface hardness.
- Oversized crankshaft bearings with greater capacity mean longer bearing life.

### Easy Maintenance

- Wet-end is easily serviced without entering crankcase, requiring less time and effort.
- Preset packings mean no packing gland adjustment is necessary, reducing maintenance costs.

### **⚠ WARNING**

All systems require both a primary pressure regulating device (i.e., regulator, unloader) and a secondary pressure safety relief device (i.e., pop-off valve, safety valve). Failure to install such relief devices could result in personal injury or damage to the pump or to system components. CAT PUMPS does not assume any liability or responsibility for the operation of a customer's high pressure system.

## SPECIFICATIONS

	U.S. Measure	Metric Measure
<b>MODEL 230 Direct-Drive</b>		
Flow .....	2.3 GPM	(8.7 L/M)
Pressure Range .....	100 to 1500 PSI	(7 to 105 BAR)
RPM .....	<b>1725 RPM</b>	<b>(1725 RPM)</b>
Stroke .....	0.276"	(7 mm)
<b>MODEL 240 Direct-Drive</b>		
Flow .....	3.6 GPM	(13.6 L/M)
Pressure Range .....	100 to 1200 PSI	(7 to 85 BAR)
RPM .....	<b>1725 RPM</b>	<b>(1725 RPM)</b>
Stroke .....	0.433"	(11 mm)
<b>MODEL 270</b>		
Flow .....	3.5 GPM	(13.2 L/M)
Pressure Range .....	100 to 1500 PSI	(7 to 105 BAR)
RPM .....	1420 RPM	(1420 RPM)
Stroke .....	0.512"	(13 mm)
<b>Alternate Specifications</b>		
Flow* .....	4.25 GPM	(16 L/M)
Pressure Range .....	100 to 1000 PSI	(7 to 70 BAR)
RPM .....	1725 RPM	(1725 RPM)
Stroke .....	0.512"	(13 mm)

\*This specification for intermittent, freshwater duty.

## COMMON SPECIFICATIONS

Bore .....	0.709"	(18 mm)
Inlet Pressure Range .....	Flooded to 60 PSI	(Flooded to 4 BAR)
Crankcase Capacity .....	15 oz.	(.45 L)
Maximum Liquid Temperature .....	160°F	(71°C)
Above 130°F call CAT PUMPS for inlet conditions and elastomer recommendations.		
Inlet Ports (2) .....	1/2" NPTF	(1/2" NPTF)
Discharge Ports (2) .....	3/8" NPTF	(3/8" NPTF)
Pulley Mounting .....	Either Side	(Either Side)
Shaft Diameter .....	0.650"	(16.5 mm)
Weight .....	13.9 lbs.	(6.3 kg)
Dimensions .....	10.22 x 8.78 x 5.30"	(259.5 x 223 x 134.5 mm)

## ELECTRIC HORSEPOWER REQUIREMENTS

MODEL	FLOW		PRESSURE			MOTOR PULLEY SIZE Using 1725 RPM Motor & Std. 5.0" Pump Pulley O.D.	
	U.S. GPM	L/M	PSI 1000 BAR 70	PSI 1200 BAR 85	PSI 1500 BAR 105	RPM	Pulley O.D.
270	4.0	15.0	2.8	N/A	N/A	1623	4.7
	3.5	13.2	2.4	2.9	3.6	1450	4.1
	3.0	11.4	2.1	2.5	3.1	1218	3.5
230	2.3	8.7	1.6	1.9	2.4	1725	Direct Drive
240	3.6	13.6	2.5	3.0	N/A	1725	Direct Drive
270	4.25	16	2.9	N/A	N/A	1725	Direct Drive

**DETERMINING THE PUMP R.P.M.**       $\frac{\text{Rated G.P.M.}}{\text{Rated R.P.M.}} = \frac{\text{"Desired" G.P.M.}}{\text{"Desired" R.P.M.}}$

**DETERMINING THE REQUIRED H.P.**       $\frac{\text{GPM} \times \text{PSI}}{1460} = \text{Electric Brake H. P. Required}$

**DETERMINING MOTOR PULLEY SIZE**       $\frac{\text{Motor Pulley O.D.}}{\text{Pump R.P.M.}} = \frac{\text{Pump Pulley O.D.}}{\text{Motor R.P.M.}}$

See complete Drive Packages [Includes: Pulleys, Belts, Hubs, Key] Tech Bulletin 003. Refer to pump **Service Manual** for repair procedure, additional technical information and **pump warranty**.

*"Customer confidence is our greatest asset"*

# PARTS LIST

ITEM	PART NUMBER			DESCRIPTION	QTY			
	230	MATL	240	MATL	270	MATL		
2	30047	STL	30047	STL	30047	STL	Key (M5x5x24)	1
5	92519	STZP	92519	STZP	92519	STZP	Screw, HHC Sems (M6x16)	8
	125824	STCP R	125824	STCP R	125824	STCP R	Screw, HHC Sems (M6x16)	8
8	27950	AL	27950	AL	27950	AL	Cover, Bearing	2
10	26536	NBR	26536	NBR	26536	NBR	O-Ring, Oil Seal Case - 70D	2
11	24159	NBR	24159	NBR	24159	NBR	Seal, Oil	2
15	14487	STLR	14487	STLR	14487	STLR	Bearing, Ball	2
20	48867	TNM	48867	TNM	48867	TNM	Rod, Connecting Assembly [09/02]	3
25	46946	FCM	46951	FCM	108062	FCM	Crankshaft, Dual End	1
31	828710	—	828710	—	828710	—	Protector, Oil Cap w/Foam Gasket	1
32	43211	ABS	43211	ABS	43211	ABS	Cap, Oil Filler	1
33	14177	NBR	14177	NBR	14177	NBR	O-Ring, Oil Filler Cap - 70D	1
37	92241		92241		92241		Gauge, Oil, Bubble w/Gasket - 80D	1
38	44428	NBR	44428	NBR	44428	NBR	Gasket, Flat, Oil Gauge - 80D	1
40	92520	STZP	92520	STZP	92520	STZP	Screw, HHC Sems (M6x20)	6
	126541	STCP R	126541	STCP R	126541	STCP R	Screw, HHC Sems (M6x20)	6
48	25625	STCP	25625	STCP	25625	STCP	Plug, Drain (1/4"x19BSP)	1
49	23170	NBR	23170	NBR	23170	NBR	O-Ring, Drain Plug - 70D	1
50	48772	AL	48772	AL	48772	AL	Cover, Rear [07/08]	1
51	48773	NBR	48773	NBR	48773	NBR	O-Ring, Rear Cover [07/08]	1
53	128354	AL	128354	AL	128354	AL	Crankcase [07/08]	1
64	16948	CM	16948	CM	16948	CM	Pin, Crosshead	3
65	45114	SSZZ	45114	SSZZ	45114	SSZZ	Rod, Plunger	3
69	126259	STCP R	126259	STCP R	126259	STCP R	Washer, Oil Seal	3
70	25301	NBR	25301	NBR	25301	NBR	Seal, Oil, Crankcase - 80D	3
71	126189	STCP R	126189	STCP R	126189	STCP R	Washer, Oil Seal	3
75	43900	S	43900	S	43900	S	Slinger, Barrier	3
88	45697	S	45697	S	45697	S	Washer, Keyhole (M18)	3
90	43901	CC	43901	CC	43901	CC	Plunger (M18x43)	3
95	126550	STCP R	126550	STCP R	126550	STCP R	Stud, Plunger Retainer (M6x43)	3
96	43235	PTFE	43235	PTFE	43235	PTFE	Back-up-Ring, Plunger Retainer	3
97	17399	NBR	17399	NBR	17399	NBR	O-Ring, Plunger Retainer - 80D	3
	14160	FPM	14160	FPM	14160	FPM	O-Ring, Plunger Retainer - 70D	3
	46204	EPDM	46204	EPDM	46204	EPDM	O-Ring, Plunger Retainer - 70D	3
98	45891	CU	45891	CU	45891	CU	Gasket, Plunger Retainer (M12.5)	3
99	46504	S	46504	S	46504	S	Retainer, Plunger (M6)	3
100	28597	PVDF	28597	PVDF	28597	PVDF	Retainer, Seal	3
106	43243	NBR	43243	NBR	43243	NBR	Seal, LPS w/S-Spg	3
	44926	FPM	44926	FPM	44926	FPM	Seal, LPS w/SS-Spg	3
	46651	EPDM	46651	EPDM	46651	EPDM	Seal, LPS w/SS-Spg	3
110	43902	BB	43902	BB	43902	BB	Manifold, Inlet	1
118	126520	STCP R	126520	STCP R	126520	STCP R	Screw, HSH Sems (M10x35)	2
125	43245	SNG	43245	SNG	43245	SNG	Seal, HPS w/S	3
	44925	FPM	44925	FPM	44925	FPM	Seal, HPS w/SS	3
	46652	HT*	46652	HT*	46652	HT*	Seal, HPS "Hi-Temp", 2-Pc w/S-Support	3
139	22179	BBCP	22179	BBCP	22179	BBCP	Plug, Inlet (1/2" NPT)	1
143	17547	NBR	17547	NBR	17547	NBR	O-Ring, Inlet Valve Adapter, Rear - 85D	3
	11685	FPM	11685	FPM	11685	FPM	O-Ring, Inlet Valve Adapter, Rear - 85D	3
	46648	EPDM	46648	EPDM	46648	EPDM	O-Ring, Inlet Valve Adapter, Rear - 70D	3
150	43904	BB	43904	BB	43904	BB	Adapter, Inlet Valve	3
154	43893	NBR	43893	NBR	43893	NBR	O-Ring, Inlet Valve Adapter, Front - 80D	3
	44927	FPM	44927	FPM	44927	FPM	O-Ring, Inlet Valve Adapter, Front	3
	46649	EPDM	46649	EPDM	46649	EPDM	O-Ring, Inlet Valve Adapter, Front - 80D	3
155	26089	NBR	26089	NBR	26089	NBR	O-Ring, Discharge Valve Adapter, Rear - 80D	3
	11377	FPM	11377	FPM	11377	FPM	O-Ring, Discharge Valve Adapter, Rear - 80D	3
	46647	EPDM	46647	EPDM	46647	EPDM	O-Ring, Discharge Valve Adapter, Rear - 80D	3
157	43905	BB	43905	BB	43905	BB	Adapter, Discharge Valve	3
159	26089	NBR	26089	NBR	26089	NBR	O-Ring, Discharge Valve Adapter, Front - 80D	3
	11377	FPM	11377	FPM	11377	FPM	O-Ring, Discharge Valve Adapter, Front - 80D	3
	46647	EPDM	46647	EPDM	46647	EPDM	O-Ring, Discharge Valve Adapter, Front - 80D	3
164	44002	S	44002	S	44002	S	Seat	6
165	44001	NBR	44001	NBR	44001	NBR	O-Ring, Seat - 80D	6
	44928	FPM	44928	FPM	44928	FPM	O-Ring, Seat - 80D	6
	46650	EPDM	46650	EPDM	46650	EPDM	O-Ring, Seat - 80D	6
166	43723	S	43723	S	43723	S	Valve	6
167	43750	S	43750	S	43750	S	Spring	6
168	43907	S	43907	S	43907	S	Retainer, Spring	6
185	43903	BB	43903	BB	43903	BB	Manifold, Discharge	1
186	12503	STZP	12503	STZP	12503	STZP	Lockwasher (M10)	4
	126231	STCP R	126231	STCP R	126231	STCP R	Lockwasher (M10)	4
188	87933	STZP	87933	STZP	87933	STZP	Screw, HSH (M10x55)	4
	126515	STCP R	126515	STCP R	126515	STCP R	Screw, HSH (M10x55)	4
250	25130	STCP	25130	STCP	25130	STCP	Protector, Shaft	1
260	30612	STZP	30612	STZP	30612	STZP	Mount, Rail, Assy	1
265	30651	—	30651	—	30651	—	Kit, Mounting (Incls: 30612, 30032, 30047, 25130)	1
270	30246	STL	30246	STL	30246	STL	Assy, Pulley (Incls: 30032, 30047)	1
							<b>[See Drive Packages, Tech Bulletin 003]</b>	
275	30942	STL	30942	STL	30942	STL	Assy, Hub & Key (M16.5 w/M5 Keyway) (Belt Drive Only)	1
277	34121	AL	34121	AL	34121	AL	Bell Housing Assy (56C-145FR, 2.0 HP)	1
	34126	AL	34126	AL	34126	AL	Bell Housing Assy (182TC-184TC, 3.0 HP)	1
278	8215	AL	8215	AL	8215	AL	Flexible Coupling Assy (M16.5 to 5/8")	1
	8225	AL	8225	AL	8225	AL	Flexible Coupling Assy (M16.5 to 1-1/8")	1

# EXPLODED VIEW

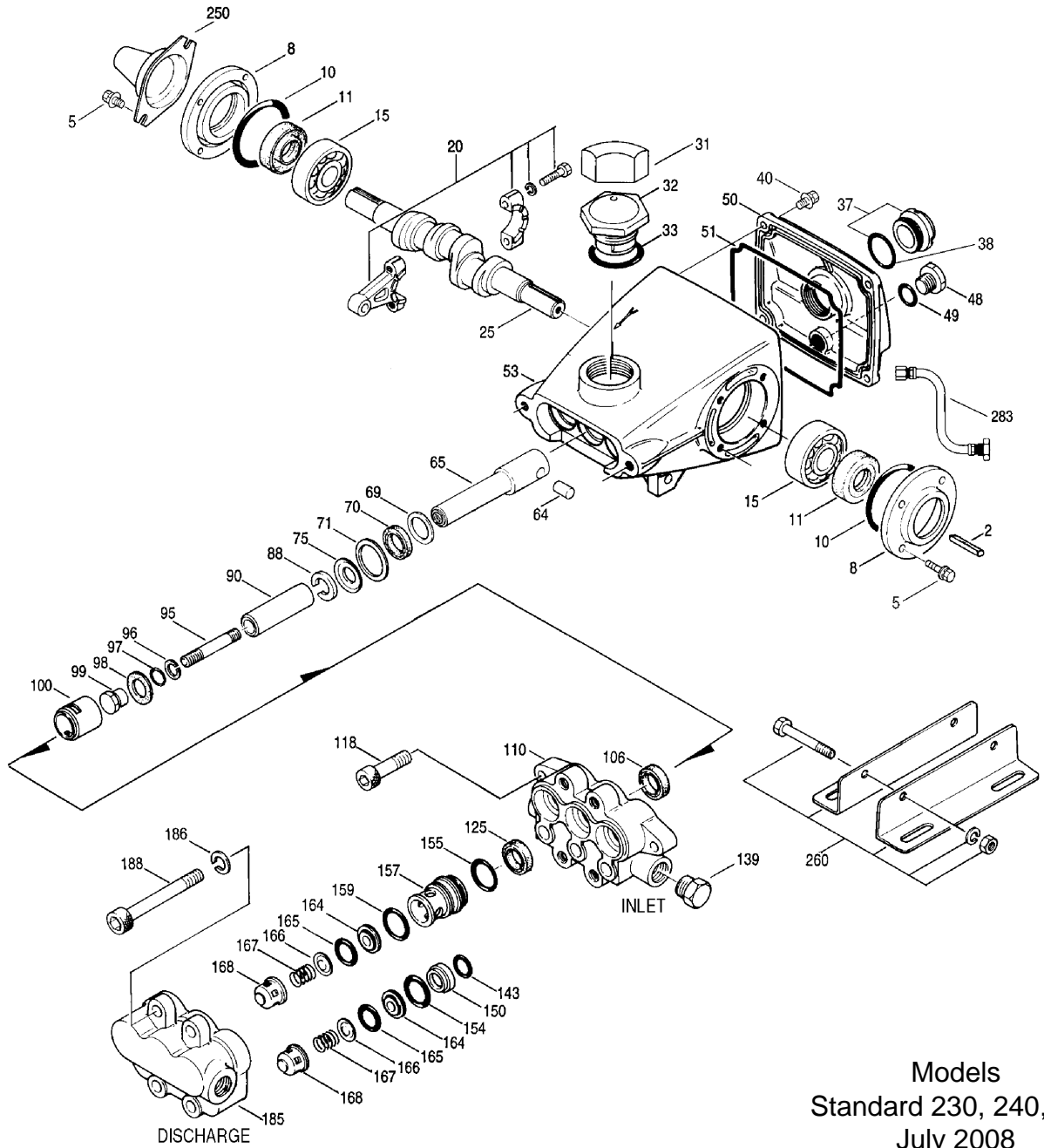

Models  
Standard 230, 240, 270  
July 2008

	<b>230</b>	<b>MATL</b>	<b>240</b>	<b>MATL</b>	<b>270</b>	<b>MATL</b>		
283	34334	—	34334	—	34334	—	Kit, Oil Drain	1
298	34961	STZP	34961	STZP	34961	STZP	Clutch Assy, Single Groove, 16.5mm, 12VDC	1
	34964	STZP	34964	STZP	34964	STZP	Clutch Assy, Dual Groove, 16.5mm, 12VDC	1
299	814611	BB	814611	BB	814611	BB	Head, Complete	1
300	30914	NBR	30914	NBR	30914	NBR	Kit, Seal (Incls: 97, 106, 125, 143, 154, 155, 159, 165)	1
	33609	FPM	33609	FPM	33609	FPM	Kit, Seal (Incls: 97, 106, 125, 143, 154, 155, 159, 165)	1
	◆ 33914	EPDM*	◆ 33914	EPDM*	◆ 33914	EPDM*	Kit, Seal (Incls: 97, 106, 125, 143, 154, 155, 159, 165)	1
	33915	HT	33915	HT	33915	HT	Kit, Seal (Incls: 97, 106, 125, 143, 154, 155, 159, 165) Hi-Temp	1
310	30915	NBR	30915	NBR	30915	NBR	Kit, Valve (Incls: 143, 154, 159, 164, 165, 166, 167, 168)	1
	31214	FPM	31214	FPM	31214	FPM	Kit, Valve (Incls: 143, 154, 159, 164, 165, 166, 167, 168)	1
	◆ 31215	EPDM	◆ 31215	EPDM	◆ 31215	EPDM	Kit, Valve (Incls: 143, 154, 159, 164, 165, 166, 167, 168)	1
350	30696	STZP	30696	STZP	30696	STZP	Plier, Reverse	1
—	—	—	—	—	—	—	BD Motors (See Individual Data Sheet)	
—	—	—	—	—	—	—	Gearbox (See Individual Data Sheet)	
—	6107	—	6107	—	6107	—	Oil, Bottle (21 oz.) ISO 68 Multi-viscosity Hydraulic (Fill to specified crankcase capacity prior to start-up)	1

**Bold print part numbers are unique to a particular pump model. Italics are optional items. [ ] Date of latest production change. ◆ Silicone oil/grease required.**

R Components comply with RoHS Directive. \*Review material codes for individual items (HT generally may be used as alternate).

See Tech Bulletins 002, 003, 024, 035, 036, 043, 067, 073, 074, 077 and 083 for additional information.

MATERIAL CODES (Not Part of Part Number): AL=Aluminum ABS=ABS Plastic BB=Brass BBCP=Brass/Chrome Plated CC=Ceramic CM=Chrome-Moly CU=Copper EPDM=Ethylene Propylene Diene Monomer FCM=Forged Chrome-moly FPM=Fluorocarbon HT=Hi-Temp (EPDM Alternative) NBR=Medium Nitrile (Buna-N) PTFE=Pure Polytetrafluoroethylene PVDF=Polyvinylidene Fluoride S=304SS SSZZ=316SS/Zamak SNG=Special Blend (Buna) STCP=Steel/Chrome Plated STL=Steel STZP=Steel/Zinc Plated TNM=Special High Strength

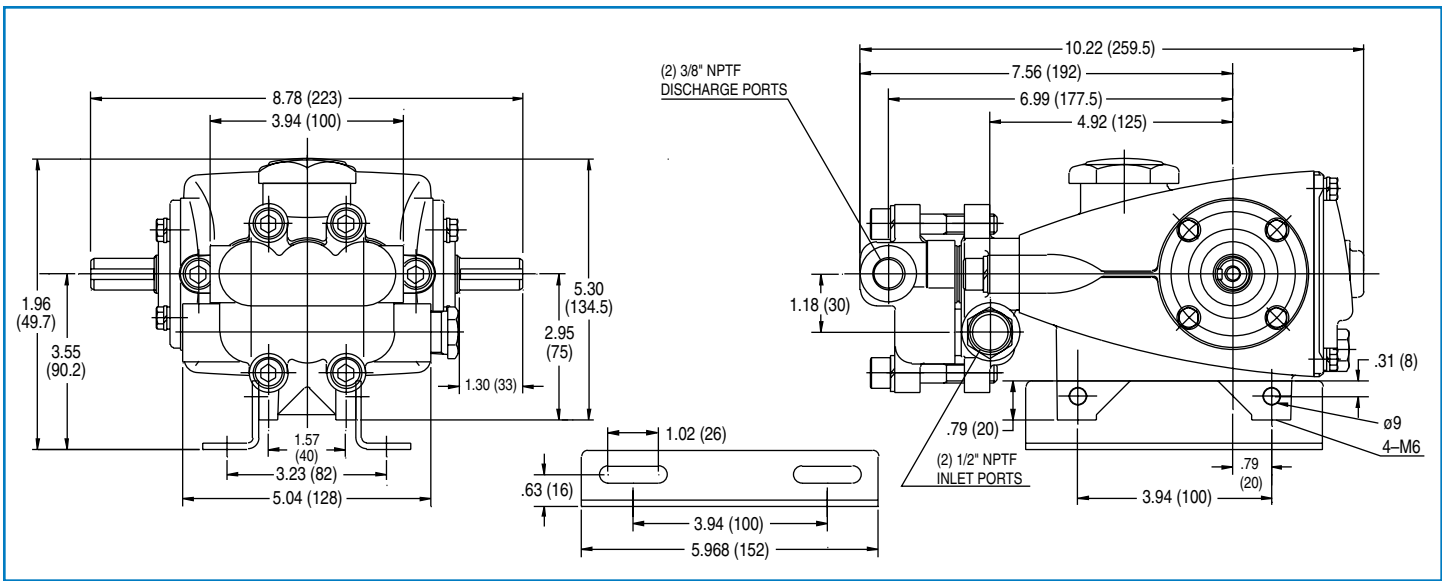

Models 230, 240, 270

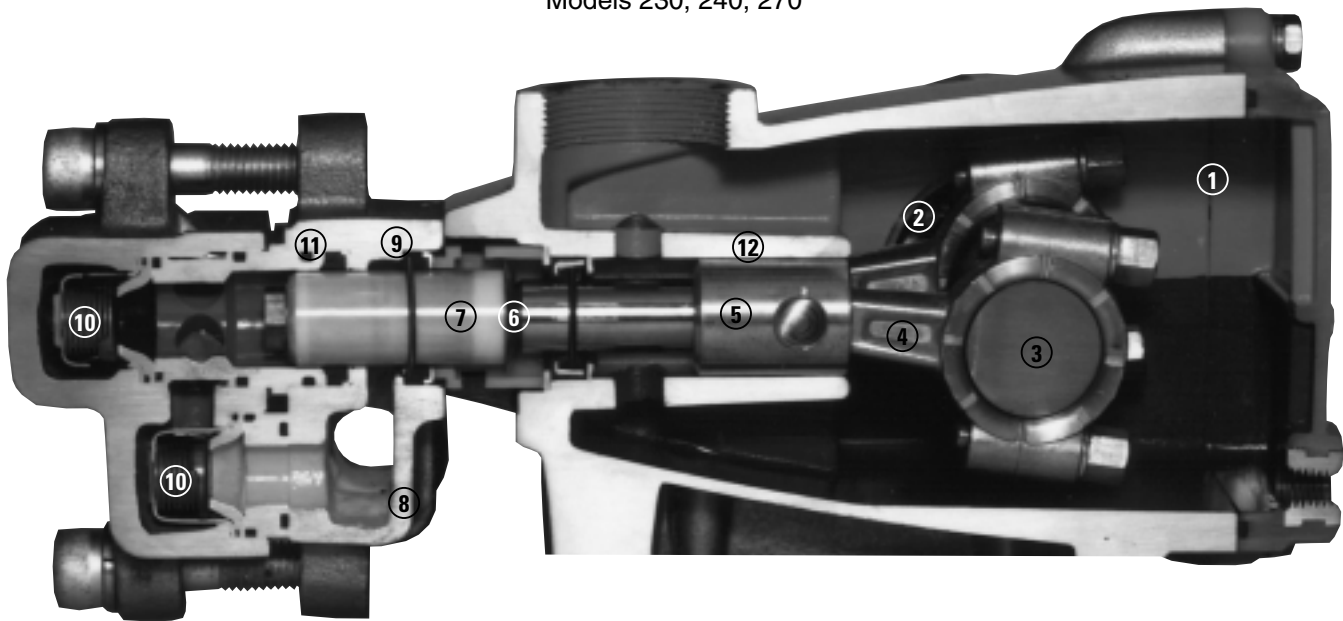

- |  |  |   |
|--|--|---|
| <p><b>1</b> Die cast aluminum <b>crankcase</b> means high strength, lightweight, and excellent tolerance control.</p> <p><b>2</b> Oversized crankshaft <b>bearings</b> provide extended bearing life and pump performance.</p> <p><b>3</b> Chrome-moly <b>crankshaft</b> provides unmatched strength and surface hardness for long life.</p> <p><b>4</b> Matched oversized TNM <b>connecting rods</b> noted for superior tensile strength and bearing quality.</p> | <p><b>5</b> The <b>plunger rods</b> are high tensile strength stainless steel with ZAMAK crossheads.</p> <p><b>6</b> The stainless steel <b>slinger</b> provides back-up protection for the crankcase seal, keeping pumped liquids out of the crankcase.</p> <p><b>7</b> Special concentric, high-density, polished, solid ceramic <b>plungers</b> provide a true wear surface and extended seal life.</p> <p><b>8</b> <b>Manifolds</b> are a high tensile strength forged brass for long term, continuous duty.</p> | <p><b>9</b> 100% wet <b>seal</b> design adds to service life by allowing pumped liquids to cool and lubricate on both sides.</p> <p><b>10</b> Stainless steel <b>valves, seats and springs</b> provide corrosion-resistance, ultimate seating and extended life.</p> <p><b>11</b> Specially formulated, CAT PUMP exclusive, <b>Hi-Pressure Seals</b> offer unmatched performance and seal life.</p> <p><b>12</b> <b>Crossheads</b> are 360° supported for uncompromising alignment.</p> |
|--|--|---|

**World Headquarters**

**CAT PUMPS**

1681 - 94th Lane N.E. Minneapolis, MN 55449-4324

Phone (763) 780-5440 — FAX (763) 780-2958

e-mail: techsupport@catpumps.com

www.catpumps.com

**International Inquiries**

FAX (763) 785-4329

e-mail: intlsales@catpumps.com



*The Pumps with Nine Lives*

**CAT PUMPS (U.K.) LTD.**

1 Fleet Business Park, Sandy Lane, Church Crookham

FLEET, Hampshire, GU52 8BF, England

Phone Fleet 44 1252-622031 — Fax 44 1252-626655

e-mail: sales@catpumps.co.uk www.catpumps.co.uk

**N.V. CAT PUMPS INTERNATIONAL S.A.**

Heiveldekens 6A, B-2550 Kontich, Belgium

Phone 32-3-450.71.50 — Fax 32-3-450.71.51

e-mail: cpi@catpumps.be www.catpumps.be

**CAT PUMPS DEUTSCHLAND GmbH**

Buchwiese 2, D-65510 Idstein, Germany

Phone 49 6126-9303 0 — Fax 49 6126-9303 33

e-mail: catpumps@t-online.de www.catpumps.de