

Electric motor must be purchased separately.

## FEATURES

- Triplex plunger design provides a smooth liquid flow.
- Specially formulated Hi-Pressure Seals and concentrically ground ceramic plungers assure maximum seal life.
- Stacked Stainless steel valve design for long life and easy servicing.
- Ultimate compact, direct-drive unit for maximum portability.
- Standard Integral Regulator with built-in by-pass assures system pressure control and pump protection.

## COMMON SPECIFICATIONS

Inlet Pressure Range.....	Flooded to 60 psi	(Flooded to 4 bar)
Bore .....	0.630"	(16 mm)
Max. Liquid Temperature .....	140°F	(60°C)
Crankcase Capacity.....	8.5 oz.	(0.25 l)
Inlet Ports (1).....	3/8" NPTF	(3/8" NPTF)
Discharge Port (1).....	3/8" NPTM	(3/8" NPTM)
Shaft Diameter .....	5/8"	(15.8 mm)
Weight.....	10.7 lbs.	(4.9 kg)
Dimensions.....	7.75 x 7.12 x 6.29"	(197 x 180 x 160 mm)

NOTE: 3450 rpm models with 1725 rpm motor deliver half original flow.

### ⚠ CAUTIONS AND WARNINGS

All High Pressure Systems require a primary pressure regulating device (i.e. regulator, unloader) and a secondary pressure relief device (i.e. pop-off valve, relief valve). Failure to install such relief devices could result in personal injury or damage to pump or property. CAT PUMPS does not assume any liability or responsibility for the operation of a customer's high pressure system.

Read all CAUTIONS and WARNINGS before commencing service or operation of any high pressure system. The CAUTIONS and WARNINGS are included in each service manual and with each Accessory Data sheet. CAUTIONS and WARNINGS can also be viewed online at [www.catpumps.com/cautions-warnings](http://www.catpumps.com/cautions-warnings) or can be requested directly from CAT PUMPS.

### WARRANTY

View the Limited Warranty on-line at [www.catpumps.com/warranty](http://www.catpumps.com/warranty).

## Direct-Drive Misting Plunger Pumps

**1725 RPM Model**      **2DX05ELS.MIST**

**3450 RPM Models**      **2DX15ES.MIST**  
**2DX20ES.MIST**  
**2DX27ES.MIST**  
**2DX30ES.MIST**

## SPECIFICATIONS

MODEL	U.S. Measure		Metric Measure		U.S. Measure		Metric Measure	
	Flow	Max. Discharge Pressure	Max. RPM	Stroke	Flow	Max. Discharge Pressure	Max. RPM	Stroke
<b>2DX05ELS.MIST</b>	0.5 gpm	2000 psi	1725 rpm	0.078"	1.89 lpm	(140 bar)	(1725 rpm)	(2.0 mm)
<b>2DX15ES.MIST</b>	1.5 gpm	2000 psi	3450 rpm	0.118"	(5.7 lpm)	(140 bar)	(3450 rpm)	(3.0 mm)
<b>2DX20ES.MIST</b>	2.0 gpm	2000 psi	3450 rpm	0.157"	(7.6 lpm)	(140 bar)	(3450 rpm)	(4.0 mm)
<b>2DX27ES.MIST</b>	2.7 gpm	2000 psi	3450 rpm	0.220"	(10.2 lpm)	(140 bar)	(3450 rpm)	(5.6 mm)
<b>2DX30ES.MIST</b>	3.0 gpm	1500 psi	3450 rpm	0.244"	(11.4 lpm)	(105 bar)	(3450 rpm)	(6.2 mm)

## ELECTRIC HORSEPOWER REQUIREMENTS

MODEL	FLOW		PRESSURE				rpm
	U.S. gpm	lpm	psi 1000	psi 1200	psi 1500	psi 2000	
			bar 70	bar 85	bar 105	bar 140	
2DX05ELS.MIST	0.5	1.89	0.34	0.41	0.51	0.68	1725
2DX15ES.MIST	1.5	5.7	1.03	1.23	1.54	2.05	3450
2DX20ES.MIST	2.0	7.6	1.37	1.64	2.05	2.74	3450
2DX27ES.MIST	2.7	10.2	1.85	2.22	2.77	3.70	3450
2DX30ES.MIST	3.0	11.4	2.05	2.46	3.08	N/A	3450

<b>DETERMINING THE PUMP R.P.M.</b>	$\frac{\text{Rated gpm}}{\text{Rated rpm}}$	=	$\frac{\text{"Desired" gpm}}{\text{"Desired" rpm}}$
<b>DETERMINING THE REQUIRED H.P.</b>	$\frac{\text{gpm} \times \text{psi}}{1460}$	=	Electric Brake H. P. Required
<b>DETERMINING MOTOR PULLEY SIZE</b>	$\frac{\text{Motor Pulley O.D.}}{\text{Pump rpm}}$	=	$\frac{\text{Pump Pulley O.D.}}{\text{Motor rpm}}$

Refer to pump **Service Manual** for repair procedure and additional technical information.

# EXPLODED VIEW

April 2011

# PLUNGER PUMP MODELS

2DX05ELS.MIST, 2DX15ES.MIST,  
2DX20ES.MIST, 2DX27ES.MIST  
2DX30ES.MIST

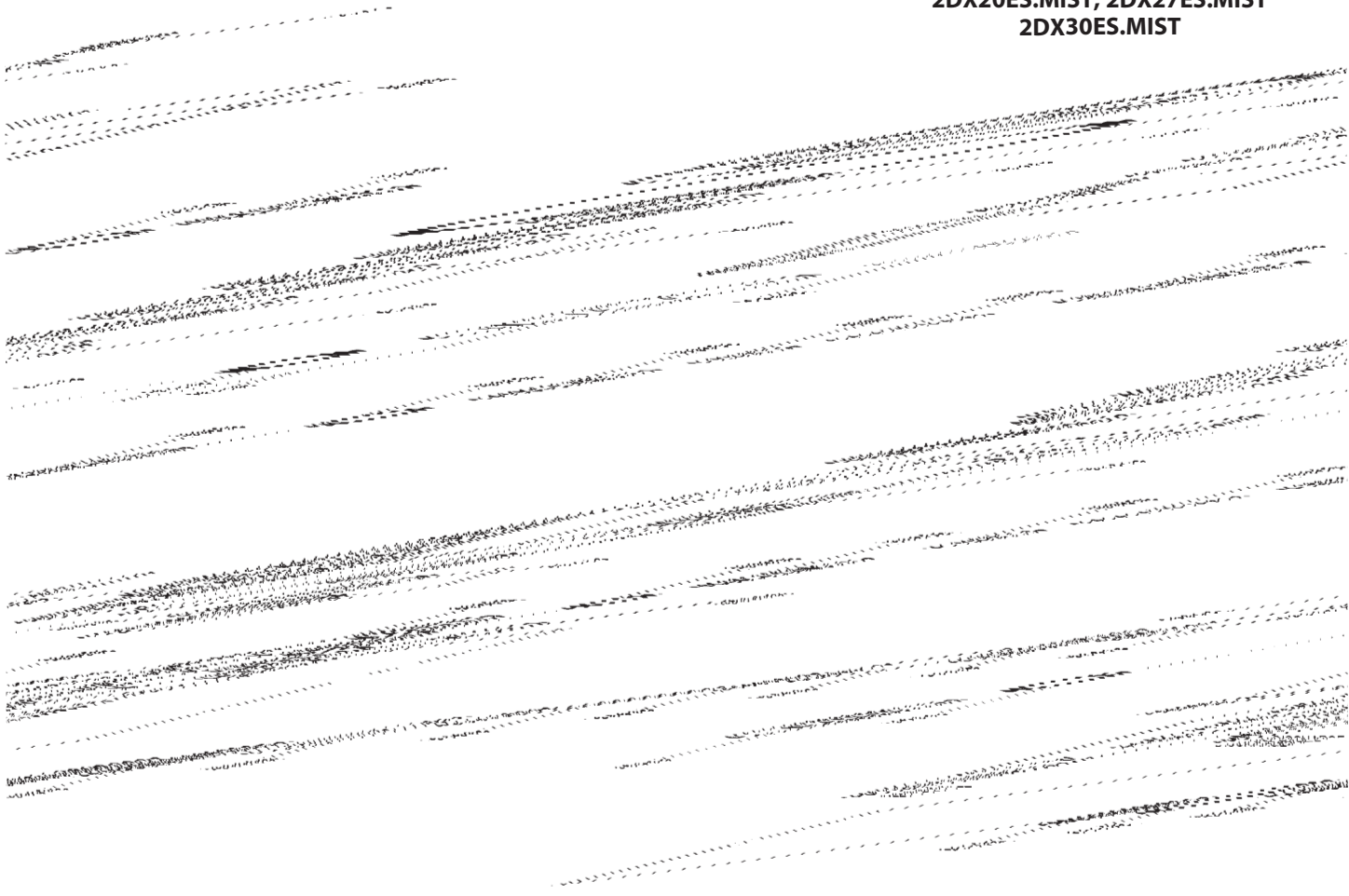

## PARTS LIST

ITEM	P/N	MATL	DESCRIPTION	MODEL USED	QTY	ITEM	P/N	MATL	DESCRIPTION	MODEL USED	QTY
5	549360	STCP R	Screw, HH (M6x14)	All Models	3	98	46730	NBR	Washer, Seal 90D	All Models	3
8	547153	AL	Cover, Bearing [04/05]	All Models	1	99	542405	S	Retainer, Plunger (M6x35)	All Models	3
10	14041	NBR	O Ring, Bearing Cover 70D	All Models	1	100	46233	D	Retainer, Seal	All Models	3
11	55337	NBR	Seal, Oil 70D	All Models	1	106	48222	NBR	Seal, LPS w/S Spg 85D	All Models	3
15	14488	STL	Bearing, Ball Inner	All Models	1	120	547357	BB	Case, Seal [02/03]	All Models	3
20	547048	TNM	Rod, Connecting	All Models	3	121	13976	NBR	O Ring, Seal Case 70D	All Models	3
24	76045	LDPE	Plug, Oil Cap (remove before startup)	All Models	1	125	46240	NBR	Seal, HPS w/S	All Models	3
25	<b>545653</b>	<b>CM</b>	Crankshaft, 1725 RPM, 5/8", 2.0 mm	05ELS.MIST	1	160	13965	NBR	O Ring, Inlet Valve Seat 70D	All Models	3
	<b>545144</b>	<b>CM</b>	Crankshaft, 3450 RPM, 5/8", 3.0 mm	15ES.MIST	1	161	545177	S	Seat, Inlet	All Models	3
	<b>545765</b>	<b>CM</b>	Crankshaft, 3450 RPM, 5/8", 4.0 mm	20ES.MIST	1	163	19285	NBR	O Ring, Seat 70D	All Models	3
	<b>545145</b>	<b>CM</b>	Crankshaft, 3450 RPM, 5/8", 5.6 mm	27ES.MIST	1	164	545178	S	Seat, Discharge	All Models	3
	<b>549901</b>	<b>CM</b>	Crankshaft, 3450 RPM, 5/8", 6.2 mm	30ES.MIST	1	166	46764	S	Valve	All Models	6
27	13832	STL	Bearing, Ball Outer	All Models	1	167	46865	S	Spring	All Models	6
32	547961	RTP	Cap, Oil Filler w/O Ring	All Models	1	168	543988	PVDF	Retainer, Spring	All Models	6
33	14179	NBR	O Ring, Oil Filler Cap 70D	All Models	1	172	142807	NBR	O Ring, Plug 90D	All Models	3
37	92241		Gauge, Bubble Oil w/Gasket	All Models	1	174	46759	BB	Plug, Valve (M20x1.5)	All Models	3
38	44428	NBR	Gasket, Flat Flex, Oil Gauge 80D	All Models	1	185	49523	BB	Head, Manifold w/Integral Regulator Body	All Models	1
48	44842	NY	Plug, Drain	All Models	1	188	542406	STZP	Screw, HSH (M6x60)	All Models	8
49	14179	NBR	O Ring, Drain Plug 70D	All Models	1		549357	STCP R	Screw, HSH (M6x60)	All Models	8
53	542407	AL	Crankcase [02/05]	All Models	1	255	30516	STZP R	Assy, Bolt Mount	All Models	1
64	46229	STL	Pin, Crosshead	All Models	3	300	33053	NBR	Kit, Seal (Incls: 98,106,121,125)	All Models	1
65	542402	BB	Rod, Plunger	All Models	3	310	33057	NBR	Kit, Valve	All Models	1
70	47215	NBR	Seal, Oil 70D	All Models	3				(Incls: 160,161,163,164,166,167,168,172)		
90	542403	CC	Plunger (M16x27)	All Models	3	400			Regulator, Integral (See Indiv. Parts)	All Models	1

**Bold Part Numbers are unique to a particular pump model. Italics are optional items.** [ ] Date of latest production change. R Components comply with RoHS Directive. View Tech Bulletins 002, 024, 036, 043, 055, 074, 083, and 094 for additional information.

MATERIAL CODES (Not Part of Part Number): AL=Aluminum BB=Brass CC=Ceramic CM Chrome moly D=Acetal LDPE=Low Density Polyethylene NBR=Medium Nitrile (Buna N) NY=Nylon PVDF=Polyvinylidene Fluoride RTP=Reinforced Composite S=304SS STL=Steel STCP=Steel/Chrome Plated STZP=Steel/Zinc Plated TNM=Special High Strength

NOTE: Discard Key which may come standard with most motors and **use only the key included in this kit.**

# INTEGRAL REGULATOR

## SPECIFICATIONS

	U.S. Measure	Metric Measure
GPM.....	3.1 gpm	(11.7 lpm)
PSI Range.....	100 2000 psi	(7 140 bar)
Discharge Port .....	3/8" NPTM	(3/8" NPTM)

## REGULATOR TYPE

An integral regulator with built-in by-pass is part of the discharge manifold to provide system pressure regulation and pump protection.

### OPERATION:

Purge pump of air before commencing operation by allowing liquid to flow through the pump without discharge restriction. Removing trapped air will assure full system pressure can be obtained.

Install a pressure gauge close to the manifold head of the pump to assist in setting system pressure and to periodically monitor system pressure.

Setting and adjusting the regulator pressure must be done with the system turned on. Start the system with the regulator backed off to the lowest pressure setting (counterclockwise direction). Read the pressure on the gauge at the pump. Do not read pressure at the nozzle. If more pressure is desired, turn adjusting cap one quarter turn in a clockwise direction and read the pressure. Repeat this process until the desired system pressure is reached.

**NOTE:** Pressure is not set at the factory.

### SERVICE:

The regulator should be serviced on the same schedule as the seals in the pump. Refer to 2DX Service Manual for start-up, servicing of seals and valves, torque requirements and diagnosis and maintenance chart.

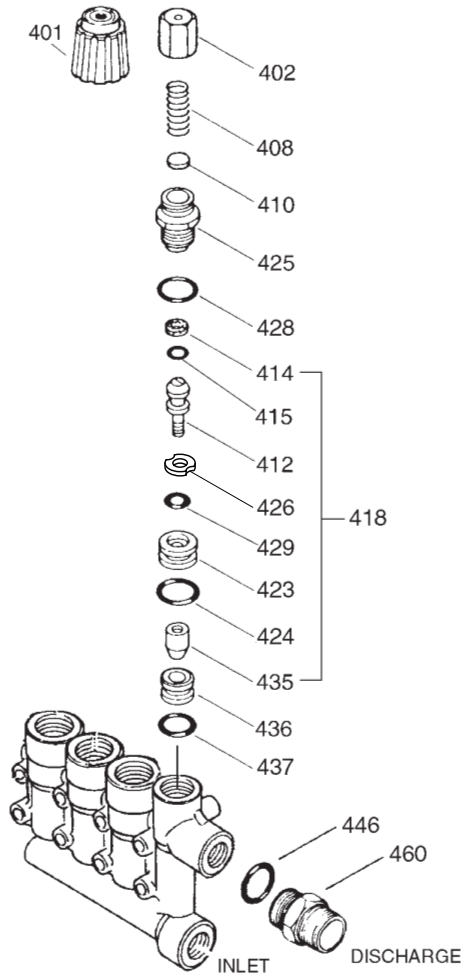

## PARTS LIST

ITEM	PN	MATL	DESCRIPTION	QTY.
401	32088	NY	Handle, Adjusting	1
402	46570	BB	Cap, Adjusting	1
408	33394	STZP R	Spring, Pressure	1
410	549352	STCP R	Retainer, Spring	1
412	46251	BB	Stem, Piston	1
414	28338	PTFE	Back up Ring, Piston Stem	1
415	22056	NBR	O Ring, Piston Stem 70D	1
418	548229	BB	Assy, Piston <i>Incls: (412,414,415,423,424,426,429,435)</i>	1
423	46249	BB	Retainer, Valve	1
424	13966	NBR	O Ring, Valve Retainer (Outer) 70D	1
425	46248	BB	Retainer, Piston	1
426	46250	S	Washer	1
428	13969	NBR	O Ring, Piston Retainer 70D	1
429	17399	NBR	O Ring, Valve Retainer (Inner) 80D	1
435	548193	S	Valve	1
436	46253	S	Seat	1
437	13963	NBR	O Ring, Seat 70D	1
446	13969	NBR	O Ring, Discharge Fitting 70D	1
460	107681	BB	Fitting, Discharge (3/8" NPTM)	1
468	33099	NBR	Kit, O Ring <i>(Incls: 414,415,424,428,429,437)</i>	1
	31088	NBR	Kit, Repair <i>(Incls: 418,428,436,437)</i>	1

*Italics are optional items. R Components comply with RoHS Directive.*

MATERIAL CODES (Not Part of Part Number):

BB=Brass NBR=Medium Nitrile (Buna N) NY=Nylon

PTFE=Pure Polytetrafluoroethylene S=304SS STCP=Steel/Chrome Plated STZP=Steel/Zinc Plated

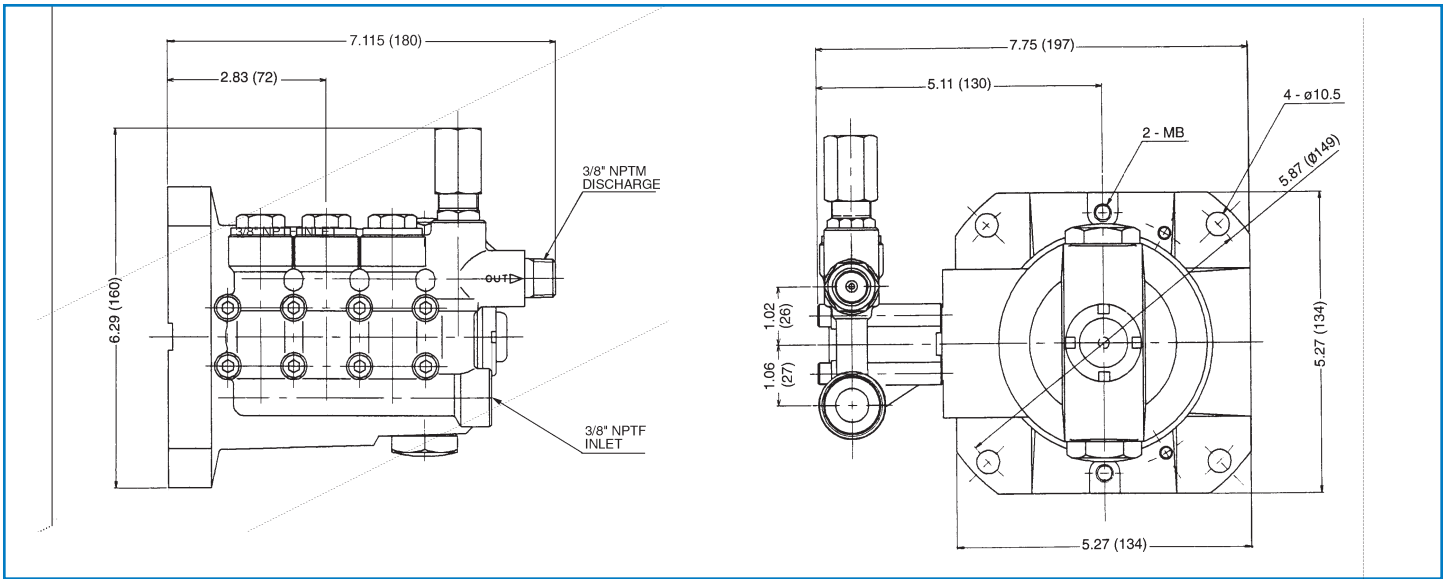

Models 2DX05ELS.MIST, 2DX15ES.MIST, 2DX20ES.MIST, 2DX27ES.MIST, 2DX30ES.MIST

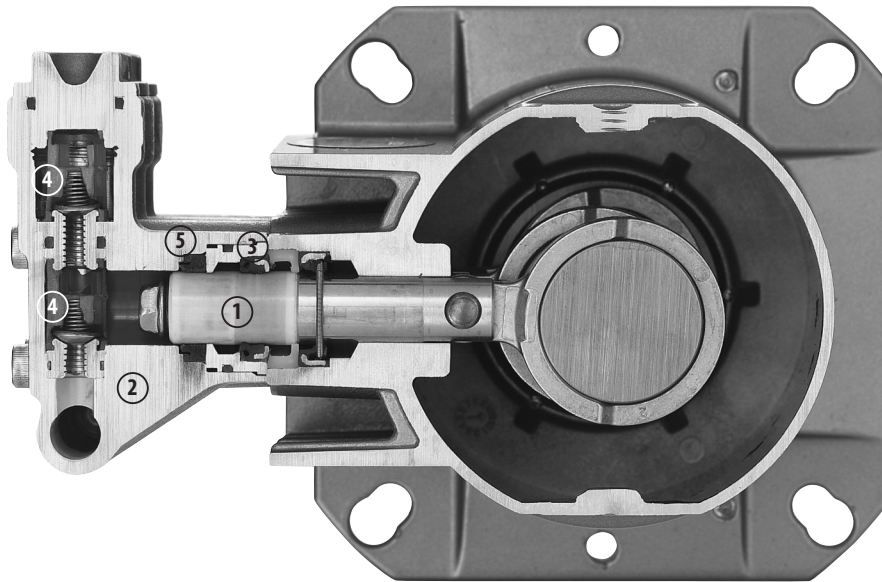

- 1 Special, concentric, high-density, polished solid ceramic **plungers** provide a true wear surface and extended seal life.
- 2 High tensile strength, forged brass **manifold head** with built-in integral regulator and eight mounting screws for exceptional strength.
- 3 100% wet **seal** design adds to service life by allowing pumped liquids to cool and lubricate on both sides.
- 4 Stainless steel **valves, seats and springs** provide corrosion-resistance, ultimate seating and extended life.
- 5 Unique design and specially formulated **Hi-Pressure Seals** offer unmatched performance and seal life.



**CAT PUMPS**  
 1681 - 94TH LANE N.E. MINNEAPOLIS, MN 55449-4324  
 PHONE (763) 780-5440 — FAX (763) 780-2958  
 e-mail: techsupport@catpumps.com  
 www.catpumps.com