

Model 311 Shown

## FEATURES

### Superior Design

- Triplex plunger design provides smoother liquid flow.
- Hi-Pressure Seals are completely lubricated and cooled by the liquid being pumped.
- Special flushed Inlet Manifold permits external flush for added cooling with high temperature liquids and lubrication with low lubricity liquids.
- Lubricated Lo-Pressure Seal provides double protection against external leakage.
- Oil bath crankcase assures optimum lubrication.
- Close tolerance concentricity of the ceramic plunger maximizes seal life.
- Optional direct drive electric motor models.

### Quality Materials

- Precision design 316 stainless steel valves and seats are hardened and polished for ultimate seating and extended valve life.
- 316 Stainless Steel or Nickel Aluminum Bronze manifolds for strength and corrosion resistance.
- Special concentric, high-density, polished, solid ceramic plungers provide a true wear surface and extended seal life.
- Specially formulated, CAT PUMP exclusive, Hi-Pressure Seals offer unmatched performance and seal life.
- Die cast aluminum crankcase provides high strength, minimum weight and precision tolerance control.
- Chrome-moly crankshaft gives unmatched strength and surface hardness.
- Oversized crankshaft bearings with greater loading capacity mean longer bearing life.

### Easy Maintenance

- Wet-end easily serviced without entering crankcase.
- Valve assemblies are accessible without disturbing piping.
- Interchangeable inlet and discharge valve assemblies.
- Preset seals require no packing adjustment.

## CAUTIONS AND WARNINGS

All High Pressure Systems require a primary pressure regulating device (i.e. regulator, unloader) and a secondary pressure relief device (i.e. pop-off valve, relief valve). Failure to install such relief devices could result in personal injury or damage to pump or property. CAT PUMPS does not assume any liability or responsibility for the operation of a customer's high pressure system.

Read all CAUTIONS and WARNINGS before commencing service or operation of any high pressure system. The CAUTIONS and WARNINGS are included in each service manual and with each Data sheet. CAUTIONS and WARNINGS can also be viewed online at [www.catpumps.com/cautions-warnings](http://www.catpumps.com/cautions-warnings) or can be requested directly from CAT PUMPS.

## WARRANTY

View the Limited Warranty on-line at [www.catpumps.com/warranty](http://www.catpumps.com/warranty).

# 5 Frame Plunger Pump

**Stainless Steel Models 311, 341, 351**  
**Stainless Steel Flushed Model 311C**  
**Nickel Aluminum Bronze Models 317, 347, 357**

## SPECIFICATIONS

U.S. Measure

Metric Measure

### MODEL 311, 311C, 317

Flow ..... 4.0 gpm (15 l/m)  
 Pressure Range ..... 100 to 2200 psi (7 to 155 bar)  
**rpm ..... 950 rpm (950 rpm)**  
 Inlet Pressure Range ..... -5 to 60 psi (-0.35 to 4 bar)  
**Stroke ..... 0.709" (18 mm)**

### MODEL 341, 347 Direct Drive

Flow ..... 4.0 gpm (15 l/m)  
 Pressure Range ..... 100 to 1800 psi (7 to 125 bar)  
**rpm ..... 1725 rpm (1725 rpm)**  
 Inlet Pressure Range ..... Flooded to 60 psi (Flooded to 4 bar)  
**Stroke ..... 0.394" (10 mm)**

### MODEL 351, 357 Direct Drive

Flow\* ..... 5.0 gpm (19 l/m)  
 Pressure Range ..... 100 to 1500 psi (7 to 105 bar)  
**rpm ..... 1725 rpm (1725 rpm)**  
 Inlet Pressure Range ..... Flooded to 60 psi (Flooded to 4 bar)  
**Stroke ..... 0.472" (12 mm)**

\*This specification for intermittent, fresh water duty.

## COMMON SPECIFICATIONS

Bore ..... 0.787" (20 mm)  
 Crankcase Capacity ..... 18 oz. (0.55 l)  
 Maximum Liquid Temperature ..... 160°F (71°C)  
 Above 130°F call CAT PUMPS for inlet conditions and elastomer recommendations.  
 Inlet Ports (2) ..... 1/2" NPTF (1/2" NPTF)  
 Flushed Ports (2) (311C Only) ..... 1/8" NPTF (1/8" NPTF)  
 Discharge Ports (2) ..... 3/8" NPTF (3/8" NPTF)  
 Shaft Diameter ..... 0.787" (20 mm)  
 Weight ..... 19.8 lbs. (9 kg)  
 Dimensions ..... 11.81 x 10.0 x 5.24" (300x254 x 133 mm)

## ELECTRIC HORSEPOWER REQUIREMENTS

MODEL	FLOW		PRESSURE					MOTOR PULLEY SIZE	
	U.S. gpm	l/m	psi 1200	psi 1500	psi 1800	psi 2000	psi 2200	rpm	Pulley O.D.
311, 311C, 317	4.0	15	4.1	5.1	N/A	N/A	N/A	1190	5.5
	5.0	19	3.3	4.1	5.0	5.5	6.0	950	4.4
	3.0	11.4	2.5	3.1	3.7	4.2	4.5	713	3.3
341, 347	4.0	15	3.3	4.1	5.0	N/A	N/A	1725	Direct Drive
351, 357	5.0	19	4.1	5.1	N/A	N/A	N/A	1725	Direct Drive

**DETERMINING THE PUMP rpm** =  $\frac{\text{Rated gpm}}{\text{Rated rpm}}$  = "Desired" gpm / "Desired" rpm  
**DETERMINING THE REQUIRED H.P.** =  $\frac{\text{gpm} \times \text{psi}}{1460}$  = Electric Brake / H. P. Required  
**DETERMINING MOTOR PULLEY SIZE** =  $\frac{\text{Motor Pulley O.D.}}{\text{Pump rpm}}$  = Pump Pulley O.D. / Motor rpm

See complete Drive Packages [Incls: Pulleys, Belts, Hubs, Key] Tech Bulletin 003. Refer to pump **Service Manual** for repair procedure and additional technical information.

*"Customer confidence is our greatest asset"*

# PARTS LIST

ITEM	PART NUMBER		DESCRIPTION	QTY
	<b>311, 311C</b>	<b>317</b>		
	<b>341</b>	<b>347</b>		
	<b>351 MATL</b>	<b>357 MATL</b>		
2	30057 STL	30057 STL	Key (M6x6x25)	1
5	92538 S	92538 S	Screw, Sems HHC (M6x16)	8
8	43344 AL	43344 AL	Cover, Bearing	1/2
10	43343 NBR	43343 NBR	O-Ring, Bearing Cover - 70D	2
11	43222 NBR	43222 NBR	Seal, Oil, Crankshaft - (311, 311C, 351-2) (341-1)	1/2
15	14480 STL	14480 STL	Bearing, Ball	2
20	45883 HS	45883 HS	Rod, Connecting Assy [09/05]	3
25	43342 FCM	43342 FCM	Crankshaft, Dual End - 311, 311C, 317	1
	44945 FCM	44945 FCM	Crankshaft, Single End - 341, 347	1
	43838 FCM	43838 FCM	Crankshaft, Dual End - 351, 357	1
30	44949 AL	44949 AL	Cover, Blind Shaft - 341	1
31	828710 —	828710 —	Protector, Oil Cap w/Foam Gasket	1
32	43211 ABS	43211 ABS	Cap, Oil Filler	1
33	14177 NBR	14177 NBR	O-Ring, Filler Cap - 70D	1
37	92241 —	92241 —	Gauge, Oil, Bubble w/Gasket	1
38	44428 NBR	44428 NBR	Gasket, Flat, Oil Gauge - 80D	1
40	92542 S	92542 S	Screw, Sems HHC (M6x20)	4
48	25625 STCP	25625 STCP	Plug, Drain (1/4"x19 BSP)	1
49	23170 NBR	23170 NBR	O-Ring, Drain Plug - 70D	1
50	48772 AL	48772 AL	Cover, Rear [10/01] (See Tech Bulletin 090)	1
51	48773 NBR	48773 NBR	O-Ring, Rear Cover [10/01] (See Tech Bulletin 090)	1
53	48769 AL	48769 AL	Crankcase [05/02] (See Tech Bulletin 090)	1
56	43355 POP	43355 POP	Pan, Oil	1
64	43351 CM	43351 CM	Pin, Crosshead	3
65	45256 SSZZ	45256 SSZZ	Rod, Plunger	3
70	43228 NBR	43228 NBR	Seal, Oil, Crankcase	3
75	43328 S	43328 S	Slinger, Barrier	3
88	45697 S	45697 S	Washer, Keyhole (M18)	3
90	43367 CC	43367 CC	Plunger (M20x72)	3
95	89653 SS	89653 SS	Stud, Plunger Retainer (M6x58)	3
96	43235 PTFE	43235 PTFE	Back-up-Ring, Plunger Retainer	3
97	17399 NBR	17399 NBR	O-Ring, Plunger Retainer - 80D	3
	14160 FPM	14160 FPM	O-Ring, Plunger Retainer - 80D	3
	◆46204 EPDM	◆46204 EPDM	O-Ring, Plunger Retainer - 70D	3
98	44041 SS	44041 SS	Gasket	3
99	44031 SS	44031 SS	Retainer, Plunger	3
100	45688 PVDF	45688 PVDF	Retainer, Seal 2-PC [04/06] (See Tech Bulletin 105)	3
101	43302 —	43302 —	Wick, Long Tab	3
106	44127 NBR	44127 NBR	Seal, LPS w/SS-Spg	3
	45153 FPM	45153 FPM	Seal, LPS w/SS-Spg	3
	◆48429 EPDM	◆48429 EPDM	Seal, LPS w/SS-Spg	3
120	45680 SS	45680 SS	Case, Seal	3
121	14200 NBR	14200 NBR	O-Ring, Seal Case - 70D	3
	11719 FPM	11719 FPM	O-Ring, Seal Case	3
	◆48907 EPDM	◆48907 EPDM	O-Ring, Seal Case	3
125	44649 SNG	44649 SNG	Seal, HPS w/SS	3
	44936 FPM	44936 FPM	Seal, HPS w/SS	3
	46667 HT*	46667 HT*	Seal, HPS "Hi-Temp", 2-Pc w/S-Support	3
139	<b>45156 SS</b>	<b>44563 NAB</b>	Plug, Inlet (1/2" NPT)	1
162	48361 D	48361 D	Back-up-Ring, Seat	6
163	43358 NBR	43358 NBR	O-Ring, Seat - 70D	6
	44938 FPM	44938 FPM	O-Ring, Seat - 70D	6
	◆48908 EPDM	◆48908 EPDM	O-Ring, Seat	6
164	44128 SS	44128 SS	Seat	6
166	44057 SS	44057 SS	Valve	6
167	44056 SS	44056 SS	Spring, Valve	6
168	44565 PVDF	44565 PVDF	Retainer, Valve Spring	6
171	44832 S	44832 S	Spring, Coil	6
172	17615 NBR	17615 NBR	O-Ring, Valve Plug - 75D	6
	15855 FPM	15855 FPM	O-Ring, Valve Plug - 70D	6
	◆48431 EPDM	◆48431 EPDM	O-Ring, Valve Plug - 75D	6
174	<b>49296 SS</b>	<b>44833 NAB</b>	Plug, Valve [05/06]	6
185	<b>45151 SS</b>	<b>44124 NAB</b>	Manifold Head (See Tech Bulletin 079 - NAB Only)	1
	49583 SS	—	Manifold Head-Flushed (311C Only)	1
186	15847 S	15847 S	Lockwasher (M10)	2
188	87950 S	87950 S	Screw HSH (M10x35) [01/04]	2
250	118672 STCP	118672 STCP	Protector, Shaft (Belt Drive Only)	1
255	30243 STZP	30243 STZP	Mount, Direct (Belt Drive Only)	1
260	30611 STZP	30611 STZP	Mount, Assy Rail - B (Belt Drive Only)	1
265	30659 —	30659 —	Mount, Assy (30611,30633,118672) (Belt Drive Only)	1
270	30633 STL	30633 STL	Assy, Pulley & Key (30058,30057) (Belt Drive Only)	1
275	30944 STL	30944 STL	Assy, Hub & Key (M20 w/M6 Keyway) (30945, 30057) (Belt Drive Only)	1
			[See Drive Packages, Tech Bulletin 003]	
283	34334 —	34334 —	Kit, Oil Drain (See Tech Bulletin 077)	1

# EXPLODED VIEW

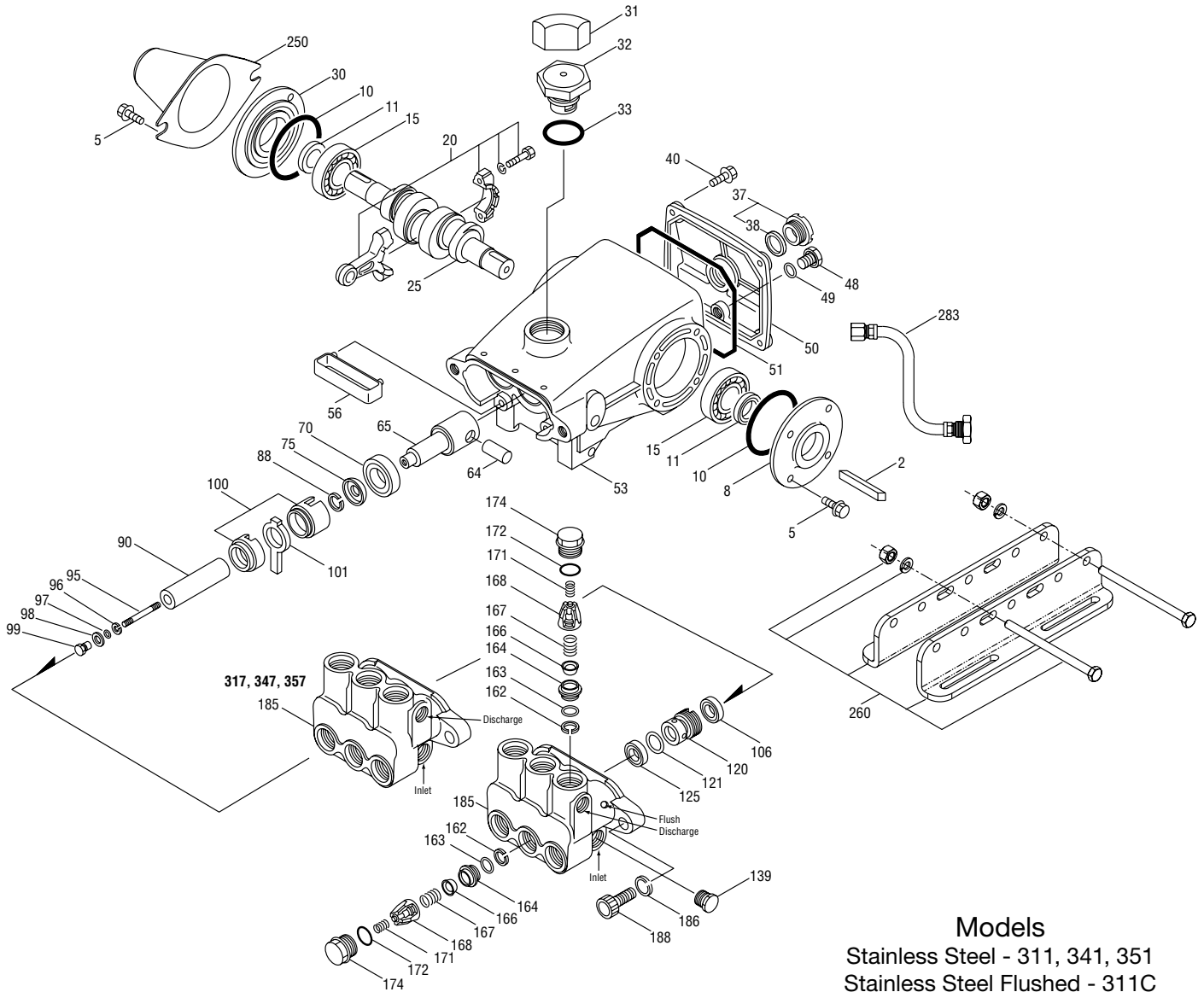

**Models**  
 Stainless Steel - 311, 341, 351  
 Stainless Steel Flushed - 311C  
 Nickel Aluminum Bronze - 317, 347, 357

	<b>311, 311C</b>	<b>341</b>	<b>351</b>	<b>MATL</b>	<b>317</b>	<b>347</b>	<b>357</b>	<b>MATL</b>		
298	34962	STZP	34962	STZP	34962	STZP	34962	STZP	Clutch Assy, Single Groove, 20mm, 12VDC	1
	34963	STZP	34963	STZP	34963	STZP	34963	STZP	Clutch Assy, Dual Groove, 20mm, 12VDC	1
299	812207	SS	814559	NAB	814559	NAB	814559	NAB	Head, Complete	1
	818444	SS	—	—	—	—	—	—	Head, Complete-Flushed (311C Only)	1
300	34153	NBR	34153	NBR	34153	NBR	34153	NBR	Kit, Seal (Incls: 97,101,106,121,125)	1
	34155	FPM	34155	FPM	34155	FPM	34155	FPM	Kit, Seal (Incls: 97,101,106,121,125)	1
	33623	HT	33623	HT	33623	HT	33623	HT	Kit, Seal, "Hi-Temp" (Incls: 97,101,106,121,125)	1
	◆ 31163	EPDM*	◆ 31163	EPDM*	◆ 31163	EPDM*	◆ 31163	EPDM*	Kit, Seal (Incls: 97,101,106,121,125)	1
310	31152	NBR	31152	NBR	31152	NBR	31152	NBR	Kit, Valve pre-assembled (Incls: 162-164,166-168,171,172)	2
	34152	FPM	34152	FPM	34152	FPM	34152	FPM	Kit, Valve pre-assembled (Incls: 162-164,166-168,171,172)	2
350	30696	STZP	30696	STZP	30696	STZP	30696	STZP	Plier, Reverse	1
351	33004	STZP	33004	STZP	33004	STZP	33004	STZP	Socket, Seal Case (1/2" Drive)	1
—	6107	—	6107	—	6107	—	6107	—	Oil, Bottle (21 oz.) ISO 68 Hydraulic (Fill to specified crankcase capacity prior to start-up)	1
—	6119	—	—	—	—	—	—	—	Lubricant, Antiseize (1 oz.) (See Tech Bulletin 095)	1

**Bold print part numbers are unique to a particular pump model. Italics are optional items. ◆ Silicone oil/grease required.**

[ ] Date of latest production change. \*Review individual parts in each kit for material code information.

Veiv Tech Bulletins 002, 003, 008, 024, 027, 032, 035, 036, 043, 045, 046, 049, 052, 053, 054, 073, 074, 077, 079, 083, 090, 095 and 105 for additional information.  
 MATERIAL CODES (Not Part of Part Number): ABS=ABS Plastic AL=Aluminum CC=Ceramic CM=Chrome-moly D=Acetal EPDM=Ethylene Propylene Diene Monomer  
 FCM=Forged Chrome-moly FPM=Fluorocarbon HS=High Strength HT=High Temp (EPDM Alternative) NAB=Nickel Aluminum Bronze NBR=Medium Nitrile (Buna-N)  
 POP=Polypropylene PTFE=Pure Polytetrafluoroethylene PVDF=Polyvinylidene Fluoride S=304SS SNG=Special Blend (Buna) SS=316SS  
 SSZZ=316SS/Zamak STL=Steel STCP=Steel/Chrome Plated STZP=Steel/Zinc Plated

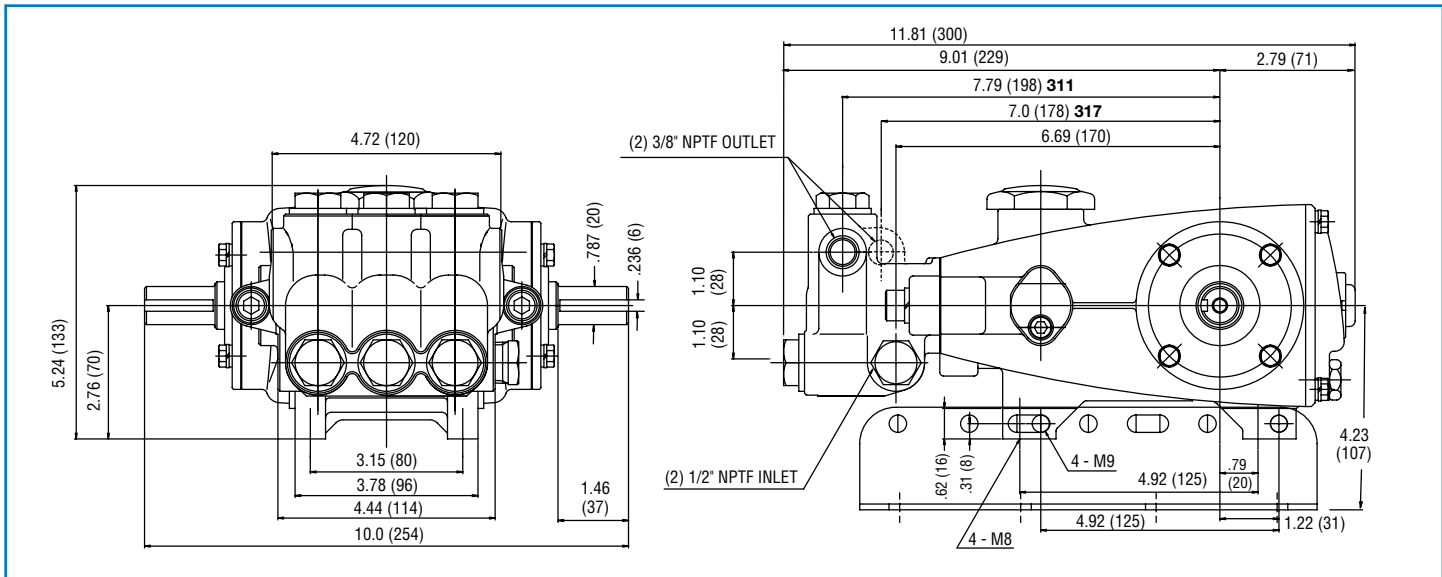

Models 311, 311C, 317, 341, 347, 351, 357



- 1 Die cast aluminum **crankcase** means high strength, lightweight, and excellent tolerance control.
- 2 Oversized crankshaft **bearings** provide extended bearing life and pump performance.
- 3 Chrome-moly **crankshaft** provides unmatched strength and surface hardness for long life.
- 4 Matched oversized high strength **connecting rods** noted for superior tensile strength and bearing quality.
- 5 Special stainless steel high strength **plunger rods** for high load bearing and longevity.
- 6 The stainless steel **slinger** provides back-up protection for the crankcase seal, keeping pumped liquids out of the crankcase.
- 7 Special concentric, high-density, polished, solid ceramic **plungers** provide a true wear surface and extended seal life.
- 8 **Manifolds** are a high tensile strength 316 stainless steel or nickel aluminum bronze for long life, continuous duty and compatibility.
- 9 100% wet **seal** design adds to service life by allowing pumped liquids to cool and lubricate on both sides.
- 10 Stainless steel **valves, seats and springs** provide corrosion-resistance, ultimate seating and extended life.
- 11 Specially formulated, CAT PUMP exclusive, **Hi-Pressure Seals** offer unmatched performance and seal life.
- 12 **Crossheads** are 360° supported for uncompromising alignment.
- 13 Special flushed **Inlet Manifold** permits external flush for added cooling with high temperature liquids and lubrication with low lubricity liquids.

**World Headquarters**

**CAT PUMPS**

1681 - 94th Lane N.E. Minneapolis, MN 55449-4324

Phone (763) 780-5440 — FAX (763) 780-2958

e-mail: techsupport@catpumps.com

www.catpumps.com

**International Inquiries**

FAX (763) 785-4329

e-mail: intl@catpumps.com



*The Pumps with Nine Lives*

**CAT PUMPS (U.K.) LTD.**

1 Fleet Business Park, Sandy Lane, Church Crookham, Fleet

Hampshire GU52 8BF, England

Phone Fleet 44 1252-622031 — Fax 44 1252-626655

e-mail: sales@catpumps.co.uk www.catpump.co.uk

**N.V. CAT PUMPS INTERNATIONAL S.A.**

Heiveldkens 6A, B-2550 Kontich, Belgium

Phone 32-3-450.71.50 — Fax 32-3-450.71.51

e-mail: cpi@catpumps.be www.catpumps.be

**CAT PUMPS DEUTSCHLAND GmbH**

Buchwiese 2, D-65510 Idstein, Germany

Phone 49 6126-9303 0 — Fax 49 6126-9303 33

e-mail: catpumps@t-online.de www.catpumps.de