

Model 3507 Shown

FEATURES

Superior Design

- Triplex plunger design gives smoother liquid flow.
- V-Packings are completely lubricated and cooled by the liquid being pumped.
- Special flushed inlet manifold lubricates and cools seals for extended life with DI water and high temp liquids.
- Lubricated Lo-Pressure Seals provide double protection against external leakage.
- Oil bath crankcase assures optimum lubrication.
- Close tolerance concentricity of the ceramic plunger maximizes seal life.

Quality Materials

- Precision design 316 stainless steel valves and seats are hardened and polished for ultimate seating and extended valve life.
- Nickel Aluminum Bronze manifolds are strong and corrosion resistant.
- Special concentric, high-density, polished, solid ceramic plungers provide a true wear surface and extended seal life.
- Specially formulated, CAT PUMP exclusive, V-Packings offer unmatched performance and seal life.
- Die cast aluminum crankcase provides high strength, minimum weight and precision tolerance control.
- Chrome-moly crankshaft gives unmatched strength and surface hardness.
- Oversized crankshaft bearings with greater loading capacity means longer bearing life.

Easy Maintenance

- Wet-end is easily serviced without entering crankcase, requiring less time and effort.
- Valve assemblies are accessible without disturbing piping, for quick service.
- Inlet and discharge valve assemblies interchange for easier maintenance.
- Preset packings mean no packing gland adjustment is necessary, reducing maintenance costs.

⚠ WARNING

All systems require both a primary pressure regulating device (i.e., regulator, unloader) and a secondary pressure safety relief device (i.e., pop-off valve, safety valve). Failure to install such relief devices could result in personal injury or damage to the pump or to system components. CAT PUMPS does not assume any liability or responsibility for the operation of a customer's high pressure system.

35 Frame Plunger Pump

Nickel Aluminum Bronze

Standard Models

3507, 3517

Flushed Models

3507C, 3517C

SPECIFICATIONS

U.S. Measure

Metric Measure

MODEL 3507

Flow	9.0 GPM	(34 L/M)
Pressure Range	100 to 5000 PSI	(7 to 345 BAR)
RPM	824 RPM	(824 RPM)
Bore	0.787"	(20 mm)
Discharge Ports (2)	3/4" NPTF	(3/4" NPTF)

MODEL 3517

Flow	14 GPM	(53 L/M)
Pressure Range	100 to 3000 PSI	(7 to 210 BAR)
RPM	800 RPM	(800 RPM)
Bore	0.984"	(25 mm)
Discharge Ports (2)	1" NPTF	(1" NPTF)

COMMON SPECIFICATIONS

Inlet Pressure Range	Flooded to 70 PSI	(Flooded to 4.9 BAR)
Stroke	1.890"	(48 mm)
Crankcase Capacity	4.2 Qts.	(4 L)
Maximum Liquid Temperature	160°F	(71°C)
Above 130°F call CAT PUMPS for inlet conditions and elastomer recommendations.		
Inlet Ports (2)	1-1/2" NPTF	(1-1/2" NPTF)
Flushing Ports (2) (3507C, 3517C)	1/4" NPTF	(1/4" NPTF)
Pulley Mounting	Either Side	(Either Side)
Shaft Diameter	1.378"	(35 mm)
Weight	152 lbs.	(69 kg)
Dimensions	24.51 x 18.11 x 9.72"	(623 x 460 x 247 mm)

ELECTRIC HORSEPOWER REQUIREMENTS

MODEL	FLOW		PRESSURE						RPM
	U.S. GPM	L/M	PSI 2000	PSI 2500	PSI 3000	PSI 4000	PSI 4500	PSI 5000	
			BAR	BAR	BAR	BAR	BAR	BAR	
			140	175	210	275	310	345	
3507	9	34	N/A	N/A	N/A	24.7	27.8	30.8	824
3507C	8	30	N/A	N/A	N/A	22.0	24.7	27.4	711
	7	27	N/A	N/A	N/A	19.2	21.6	24.0	622
3517	14	53	19.2	24.0	28.8	N/A	N/A	N/A	800
3517C	12	45	16.5	20.6	24.7	N/A	N/A	N/A	685
	10	38	13.7	17.2	20.6	N/A	N/A	N/A	571

DETERMINING THE PUMP R.P.M.

$\frac{\text{Rated G.P.M.}}{\text{Rated R.P.M.}} = \frac{\text{"Desired" G.P.M.}}{\text{"Desired" R.P.M.}}$

DETERMINING THE REQUIRED H.P.

$\frac{\text{GPM} \times \text{PSI}}{1460} = \text{Electric Brake H. P. Required}$

DETERMINING MOTOR PULLEY SIZE

$\frac{\text{Motor Pulley O.D.}}{\text{Pump R.P.M.}} = \frac{\text{Pump Pulley O.D.}}{\text{Motor R.P.M.}}$

See complete Drive Packages [Incls: Pulleys, Belts, Hubs, Key] Tech Bulletin 003.
Refer to pump **Service Manual** for repair procedure, additional technical information and **pump warranty**.

"Customer confidence is our greatest asset"

PARTS LIST

ITEM	PART NUMBER		DESCRIPTION	QTY
	3507	3517		
2	34021	34021	Key (M10x8x70)	1
5	125753	125753	Screw, HH Sems (M8x25)	8
8	44542	44542	Cover, Bearing	2
9	815279	815279	Shim, Split, 2 pc	2
10	12398	12398	O-Ring, Bearing Cover - 70D	2
11	13296	13296	Seal, Oil, Crankshaft	2
15	29326	29326	Bearing, Roller	2
20	121467	121467	Rod, Connecting Assy (Incls: 21, 22, 23) [10/00]	3
21	126749	126749	Washer, Locking (M10)	3
22	12490	12490	Washer, Flat (M10)	6
	126574	126574	Washer, Flat (M10)	6
23	122045	122045	Screw, HH (M10x55)	6
25	29325	29325	Crankshaft, Dual End (M48)	1
31	828710	828710	Protector, Oil Cap w/Foam Gasket	1
32	43211	43211	Cap, Oil Filler	1
33	14177	14177	O-Ring, Oil Filler Cap - 70D	1
34	126743	126743	Bolt, Eye (M12x1.75) (For Lifting Pump Only)	1
37	92241	92241	Gauge, Bubble Oil w/Gasket - 80D	1
38	44428	44428	Gasket, Flat Oil Gauge - 80D	1
40	125753	125753	Screw, HH Sems (M8x25)	8
48	25625	25625	Plug, Drain (1/4"x19BSP)	1
49	23170	23170	O-Ring, Drain Plug - 70D	1
50	45936	45936	Cover, Rear	1
51	16612	16612	O-Ring, Cover - 70D	1
53	44487	44487	Crankcase Assy (Incls: 34, 54)	1
54	27488	27488	Pin, Guide	2
56	27790	27790	Pan, Oil	1
59	92538	92538	Screw, HHC Sems (M6x16)	2
64	43864	43864	Pin, Crosshead	3
65	45118	45118	Rod, Plunger	3
69	126587	126587	Washer, Oil Seal	3
70	100488	100488	Seal, Oil, Crankcase	3
	44739	44739	Seal, Oil, Crankcase	3
75	43506	43506	Slinger, Barrier	3
88	45675	45675	Washer, Keyhole	3
90	43945	43945	Plunger (M20x145)	3
	—	43866	Plunger (M25x145)	3
95	89779	89779	Stud, Retainer (M7x123)	3
	—	89778	Stud, Retainer (M10x135)	3
96	20184	20189	Back-up-Ring, Plunger Retainer	3
97	14190	11345	O-Ring, Plunger Retainer - 70D	3
	14161	11375	O-Ring, Plunger Retainer	3
98	44069	—	Gasket, Plunger Retainer (M7)	3
	—	44085	Gasket, Plunger Retainer (M10)	3
99	44068	—	Retainer, Plunger (M7)	3
	—	44084	Retainer, Plunger (M10)	3
100	814279	814279	Retainer, Seal, 2 Pc.	3
101	44095	44096	Wick	3
104	43875	43875	O-Ring, Adapter - 70D	3
	44826	44826	O-Ring, Adapter - 70D	3
105	44073	44088	Adapter, LPS	3
106	44071	44086	Seal, LPS w/SS-Spg	3
	44381	45846	Seal, LPS w/SS-Spg	3
107	44074	44089	Washer, LPS	3
110	44206	44206	Manifold, Inlet	1
	125970	125970	Manifold, Inlet, Flushed (1/4" Inlet Port) 3507C, 3517C	1
112	11379	11379	O-Ring, Inlet Manifold - 70D	3
	14183	14183	O-Ring, Inlet Manifold	3
117	44585	44585	Screw, HSH (M14x40)	4
123	12391	12391	O-Ring, V-Packing Cylinder - 70D	3
	13266	13266	O-Ring, V-Packing Cylinder - 70D	3
124	44075	44090	Cylinder, V-Packing	3
126	44076	44091	Adapter, Female	3
127	44607	—	V-Packing	9
	—	44610	V-Packing	6
128	44077	44092	Adapter, Male	3
155	17622	11379	O-Ring, V-Packing Spacer	6
	11719	14183	O-Ring, V-Packing Spacer	6
156	28675	28243	Back-up-Ring, V-Packing Spacer	6
157	46668	44093	Spacer, V-Packing	3
162	21985	21985	Back-up-Ring, Seat	6
163	26089	26089	O-Ring, Seat - 80D	6
	11377	11377	O-Ring, Seat - 80D	6
164	44080	44080	Seat	6
166	44081	44081	Valve	6
167	44082	44082	Spring	6
168	44735	44735	Retainer, Spring	6
170	44794	44794	Washer, Spring Retainer	6
171	44793	44793	Spring, Coil, Valve Plug	6
172	15853	15853	O-Ring, Valve Plug - 70D	6
	11720	11720	O-Ring, Valve Plug - 70D	6
173	20224	20224	Back-up-Ring, Valve Plug	6
174	44795	44795	Plug, Valve	6
175	87951	87951	Screw, HSH (M10x30)	36
185	46561	46565	Manifold, Discharge [10/99]	1
188	89981	89981	Screw, HSH (M12x70)	8
250	44516	44516	Protector, Shaft, w/2 Screws, Lockwashers and Washers (Included with Pump)	1
255	34018	34018	Assy, Direct Mount	1
—	34039	34039	Assy, Direct Mount	1
260	92674	92674	Mounting, Rail, Assy (Incls: 34018)	1

EXPLODED VIEW

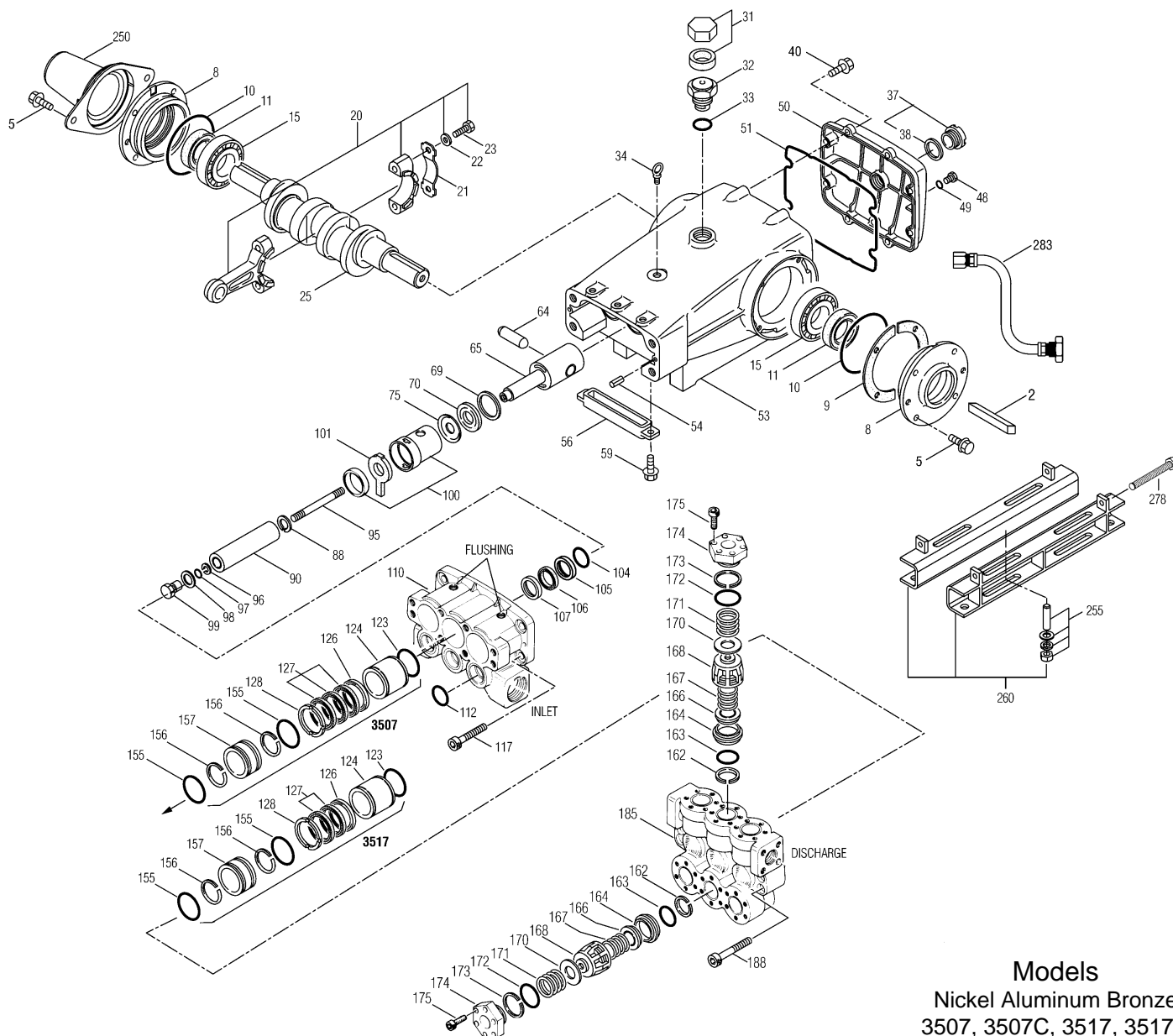

Models
Nickel Aluminum Bronze
3507, 3507C, 3517, 3517C
February 2008

	3507	MATL	3517	MATL		
275	990013	STL	990013	STL	Hub, 'B' 35mm w/Keyway [See Drive Packages, Tech Bulletin 003]	1
278	80540	ZP	80540	ZP	Screw, HH (M12x100) (Rail Adjusting Screw)	1
279	30278	STZP	30278	STZP	Oiler (1 oz.)	3
281	30967	—	30967	—	Glass, Oiler	3
282	10069	NBR	10069	NBR	Gasket, Oiler	3
283	34314	—	34314	—	Kit, Oil Drain	1
290	6124	—	6124	—	Gasket, Liquid (3 oz.)	1
299	816755	NAB	816750	NAB	Head, Complete	1
300	31037	NBR*	31038	NBR*	Kit, Seal (Incls: 97,104,106,112,123,127,155,156)	1
	33265	FPM*	31266	FPM*	Kit, Seal (Incls: 97,104,106,112,123,127,155,156)	1
310	34151	NBR	34151	NBR	Kit, Valve (Incls: 162,163,164,166,167,168,170,172,173)	2
	701798	FPM	701798	FPM	Kit, Valve (Incls: 162,163,164,166,167,168,170,172,173)	2
390	711500	SS	711500	SS	C.A.T. (Inlet pressure stabilizer for RO and boosted inlet applications)	1
391	711506	SS	711506	SS	Adapter (2 per C.A.T.) (See Data Sheet for complete selection)	2
—	819000	F	819000	F	Assy, Crankcase, Cast Iron Conversion	1
—	6575	—	6575	—	Plunger Pump Service DVD	1
—	6100	—	6100	—	Oil, Case (12 Bottles) ISO 68 Multi-viscosity Hydraulic (Fill to specified crankcase capacity prior to start-up)	1

Bold print part numbers are unique to a particular pump model. Italics are optional items. [] Date of latest production change.
R Components comply with RoHS Directive. *Review material codes for individual items (STG generally may be used as alternate).

C.A.T. highly recommended for pressurized inlet, R.O. and Industrial applications.

See Tech Bulletins 002, 003, 024, 035, 036, 041, 043, 052, 053, 068, 069, 074, 077, 080 and 083 for additional information.

MATERIAL CODES (Not Part of Part Number): ABS=ABS Plastic AL=Aluminum BB=Brass BBCP=Brass/Chrome Plated CC=Ceramic CM=Chrome-Moly F=Cast Iron
FBR=Fiber FCM=Forged Chrome-moly FPM=Fluorocarbon NAB=Nickel Aluminum Bronze NBR=Medium Nitrile (Buna-N)
NBRS=Buna, Silicone Free NY=Nylon POP=Polypropylene PTFE=Pure Polytetrafluoroethylene PVDF=Polyvinylidene Fluoride S=304SS SS=316SS
SSL=316SS/Low Carbon STG=Special Blend PTFE White SSZZ=316SS/Zamak STL=Steel STCP=Steel/Chrome Plated STZP=Steel/Zinc Plated
TNN=Special High Strength ZP=Zinc Plated

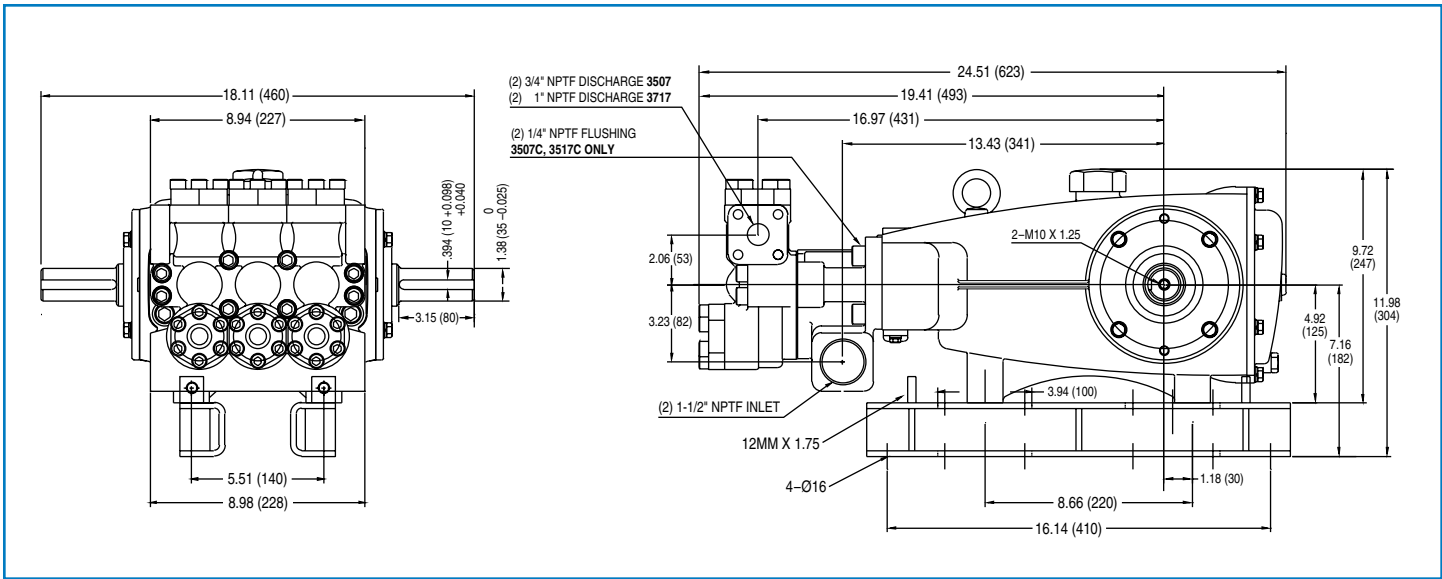

Models 3507, 3507C, 3517, 3517C

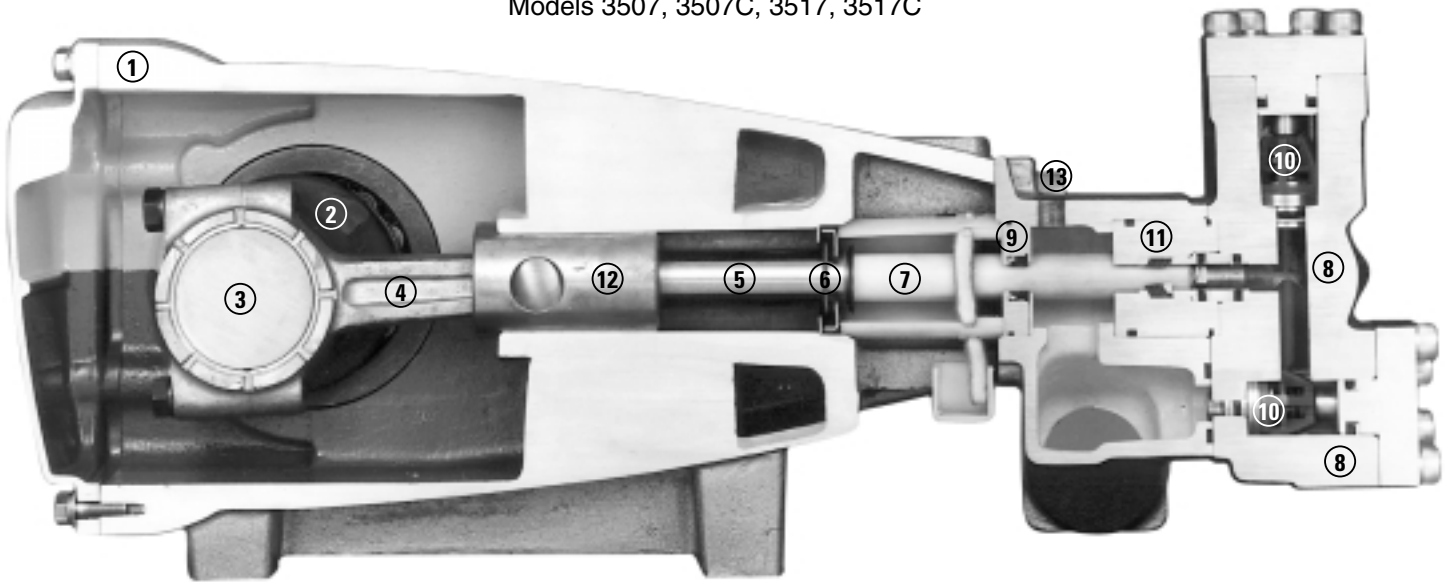

- 1 Die cast aluminum **crankcase** means high strength, lightweight, and excellent tolerance control.
- 2 Oversized crankshaft **bearings** provide extended bearing life and pump performance.
- 3 Chrome-moly **crankshaft** provides unmatched strength and surface hardness for long life.
- 4 Matched oversized TNM **connecting rods** noted for superior tensile strength and bearing quality.
- 5 Special stainless steel **plunger rods** with high strength crossheads for longevity and corrosion resistance.
- 6 The stainless steel **slinger** provides back-up protection for the crankcase seal, keeping pumped liquids out of the crankcase.
- 7 Special concentric, high-density, polished, solid ceramic **plungers** provide a true wear surface and extended seal life.
- 8 **Manifolds** are high tensile strength nickel aluminum bronze for long term, continuous duty.
- 9 100% wet **seal** design adds to service life by allowing pumped liquids to cool and lubricate on both sides.
- 10 Stainless steel **valves, seats and springs** provide corrosion-resistance, ultimate seating and extended life.
- 11 Specially formulated, CAT PUMP exclusive, **V-Packings** offer unmatched performance and seal life.
- 12 **Crossheads** are 360° supported for uncompromising alignment.
- 13 Optional special **ported Flushed Inlet Manifold** permits external flush for lubricating and cooling seals when pumping liquids such as DI water, Hi-Temp or low lubricity.

World Headquarters

CAT PUMPS

1681 - 94th Lane N.E. Minneapolis, MN 55449-4324

Phone (763) 780-5440 — FAX (763) 780-2958

e-mail: techsupport@catpumps.com

www.catpumps.com

International Inquiries

FAX (763) 785-4329

e-mail: intlsales@catpumps.com



The Pumps with Nine Lives

CAT PUMPS (U.K.) LTD.

1 Fleet Business Park, Sandy Lane, Church Crookham

FLEET, Hampshire, GU52 8BF, England

Phone Fleet 44 1252-622031 — Fax 44 1252-626655

e-mail: sales@catpumps.co.uk

N.V. CAT PUMPS INTERNATIONAL S.A.

Heiveldekens 6A, B-2550 Kontich, Belgium

Phone 32-3-450.71.50 — Fax 32-3-450.71.51

e-mail: cpi@catpumps.be www.catpumps.be

CAT PUMPS DEUTSCHLAND GmbH

Buchwiese 2, D-65510 Idstein, Germany

Phone 49 6126-9303 0 — Fax 49 6126-9303 33

e-mail: catpumps@t-online.de www.catpumps.de