

Gas engine must be purchased separately.

FEATURES

- Triplex plunger design provides a smooth liquid flow.
- Specially formulated V-Packings and concentric solid ceramic plungers assure true wear surface and extended seal life.
- Stacked valve design for ease in servicing.
- Ultra-compact, hollow-shafted pump for direct mounting to gas engine.
- Integral Pressure Unloader with built-in by-pass standard on all units to assure system pressure control and pump protection.
- Fixed chemical injector standard on all units offers cleaning flexibility.
- Swivel garden hose fitting for easy inlet connection.

⚠ CAUTIONS AND WARNINGS

All High Pressure Systems require a primary pressure regulating device (i.e. regulator, unloader) and a secondary pressure relief device (i.e. pop-off valve, relief valve). Failure to install such relief devices could result in personal injury or damage to pump or property. CAT PUMPS does not assume any liability or responsibility for the operation of a customer's high pressure system.

Read all CAUTIONS and WARNINGS before commencing service or operation of any high pressure system. The CAUTIONS and WARNINGS are included in each service manual and with each Accessory Data sheet. CAUTIONS and WARNINGS can also be viewed online at www.catpumps.com/cautions-warnings or can be requested directly from CAT PUMPS.

WARRANTY

View the Limited Warranty on-line at www.catpumps.com/warranty.

Direct-Drive Plunger Pumps

Models

3DNX25GSI 3DNX27GSI

SPECIFICATIONS

MODEL 3DNX25GSI

	U.S. Measure	Metric Measure
Flow.....	2.5 gpm	(9.5 lpm)
Maximum Discharge Pressure.....	2850 psi	(196 bar)
Maximum RPM.....	3450 rpm	(3450 rpm)
Stroke.....	0.268"	(6.8 mm)

MODEL 3DNX27GSI

Flow.....	2.7 gpm	(10.2 lpm)
Maximum Discharge Pressure.....	2850 psi	(196 bar)
Maximum RPM.....	3450 rpm	(3450 rpm)
Stroke.....	0.280"	(7.2 mm)

COMMON PUMP SPECIFICATIONS

Inlet Pressure Range.....	Flooded to 60 psi	(Flooded to 4 bar)
Bore.....	0.551"	(14 mm)
Crankcase Capacity.....	8.5 oz.	(0.25 l)
Maximum Liquid Temperature.....	140°F	(60°C)
Above 130°F call CAT PUMPS for inlet conditions and elastomer recommendations.		
Inlet Ports (1).....	3/4" GHF	(3/4" GHF)
Accessory Port (1).....	1/4" NPTF	(1/4" NPTF)
Discharge Port (1).....	M18 x 1.0	(M18 x 1.0)
Chemical Discharge Port (1).....	3/8" NPTM	(3/8" NPTM)
Chemical Injection Hose Barb.....	1/4"	(1/4")
Shaft Diameter (Hollow).....	3/4"	(19.0 mm)
Weight.....	10.7 lbs.	(4.9 kg)
Dimensions.....	8.03 x 7.83 x 6.61"	(204 x 199 x 168 mm)

ELECTRIC HORSEPOWER REQUIREMENTS

MODELS	FLOW		PRESSURE					RPM
			psi 1000	psi 1200	psi 1500	psi 2000	psi 2850	
	U.S. gpm	lpm	bar 70	bar 85	bar 105	bar 140	bar 196	
3DNX25GSI	2.5	9.5	1.7	2.0	2.6	3.4	4.9	3450
3DNX27GSI	2.7	10.2	1.8	2.2	2.8	3.7	5.3	3450

DETERMINING THE PUMP R.P.M.	$\frac{\text{Rated gpm}}{\text{Rated rpm}}$	=	$\frac{\text{"Desired" gpm}}{\text{"Desired" rpm}}$
DETERMINING THE REQUIRED H.P.	$\frac{\text{gpm} \times \text{psi}}{1460}$	=	Electric Brake H. P. Required
DETERMINING MOTOR PULLEY SIZE	$\frac{\text{Motor Pulley O.D.}}{\text{Pump rpm}}$	=	$\frac{\text{Pump Pulley O.D.}}{\text{Motor rpm}}$

Refer to pump **Service Manual** for repair procedure and additional technical information.

EXPLODED VIEW

April 2011

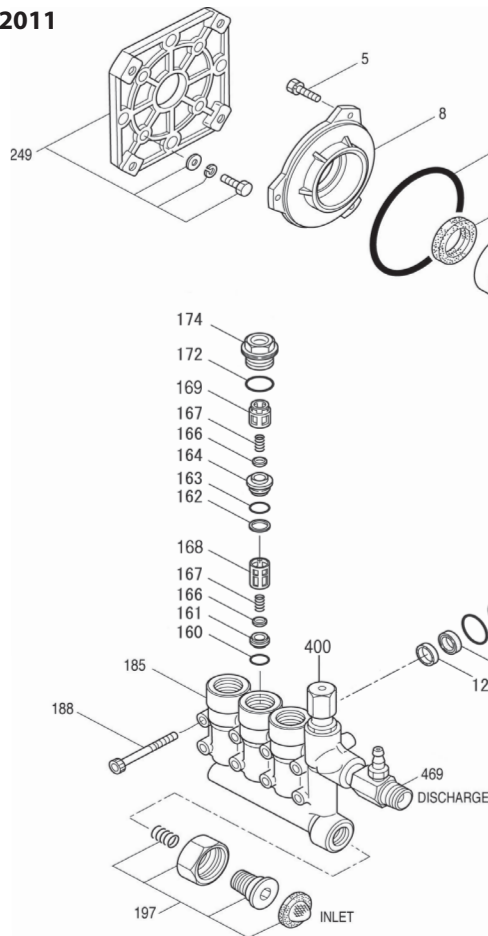

PLUNGER PUMP MODELS

3DNX25GSI, 3DNX27GSI

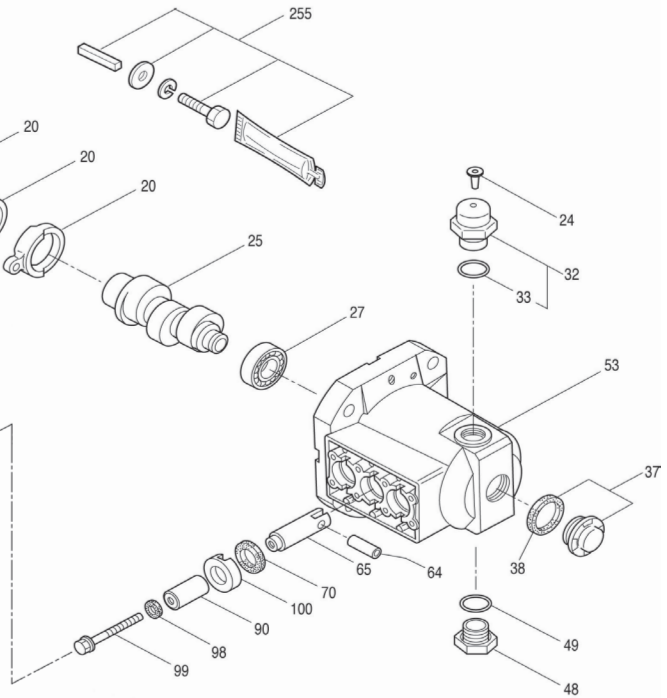

PARTS LIST

ITEM	P/N	MATL	DESCRIPTION	QTY	ITEM	P/N	MATL	DESCRIPTION	QTY
5	549360	STCP R	Screw, HH (M6x14)	3	127	547082	SNG	V Packing	3
8	547153	AL	Cover, Bearing	1	128	547083	PVDF	Adapter, Male	3
10	14041	NBR	O Ring, Bearing Cover 70D	1	160	17428	NBR	O Ring, Inlet Seat 80D	3
11	55337	NBR	Seal, Oil 70D	1	161	547077	S	Seat, Inlet	3
15	14488	STL	Bearing, Ball Inner	1	162	48361	D	Back up Ring, Discharge Seat	3
20	547048	TNM	Rod, Connecting	3	163	43358	NBR	O Ring, Discharge Seat 70D	3
24	549608	LDPE	Plug, Oil Cap	1	164	547076	S	Seat, Discharge	3
25	549446	CM	Crankshaft, 3450 RPM, 3/4", 6.8 mm	1	166	547098	S	Valve	6
	548558	CM	Crankshaft, 3450 RPM, 3/4", 7.2 mm	1	167	46865	S	Spring	6
27	56084	STL	Bearing, Ball	1	168	543988	PVDF	Retainer, Spring, Inlet	3
32	547961	RTP	Cap, Oil Filler w/O Ring	1	169	547441	PVDF	Retainer, Spring, Discharge	3
33	14179	NBR	O Ring, Oil Filler Cap 70D	1	172	142807	NBR	O Ring, Plug 90D	3
37	92241		Gauge, Bubble Oil w/Gasket	1	174	547078	BB	Plug, Valve (M20x15)	3
38	44428	NBR	Gasket, Flat Flex, Oil Gauge 80D	1	185	548509	BB	Head, Manifold w/Integral Regulator Body	1
48	44842	NY	Plug, Drain	1	188	542406	STZP	Screw, HSH (M6x60)	8
49	14179	NBR	O Ring, Drain Plug 70D	1		549357	STCP R	Screw, HSH (M6x60)	8
53	548062	AL	Crankcase	1	197	941516	BB	Assy, GH, 3/8"	1
64	46229	STL	Pin, Crosshead	3				Nut, Swivel (3/4"FGH)	1
65	542402	BB	Rod, Plunger	3				Fitting, (3/8" NPTM)	1
70	47215	NBR	Seal, Oil 70D	3				Screen, Inlet	1
90	547091	CC	Plunger (M14x25.5)	3				Spring	1
98	46730	NBR	Washer, Seal 90D	3	249	30520		Assy, Adapter Mount	1
99	542405	S	Retainer, Plunger (M6x35)	3	255	30516	STZP R	Assy, Bolt Mount	1
100	46233	D	Retainer, Seal	3	283	990394		Kit, Oil Drain (Not Shown)	1
106	45188	NBR	Seal, LPS w/S Spg	3	300	31684	NBR	Kit, Seal (Incls: 98,106,121,127,128)	1
120	548559	BB	Case, Seal	3	310	31647	NBR	Kit, Valve (Incls: 160,161,162,163,164,166,167,168,169,172)	1
121	13976	NBR	O Ring, Seal Case 70D	3	400			Unloader, Integral (See Individual Parts)	1
					469	7332	BB	Injector, Chemical Fixed	1

Bold Part Numbers are unique to a particular pump model. Italics are optional items. [] Date of latest production change. R Components comply with RoHS Directive.

View Tech Bulletins 002, 024, 036, 043, 055, 074 and 083 for additional information.

MATERIAL CODES (Not Part of Part Number): AL=Aluminum BB=Brass CC=Ceramic CM Chrome moly D=Acetal LDPE=Low Density Polyethylene NBR=Medium Nitrile (Buna N) NY=Nylon PVDF=Polyvinylidene Fluoride RTP=Reinforced Composite S=304SS SNG=Special Blend (Buna) STL=Steel STCP=Steel/Chrome Plated STZP=Steel/Zinc Plated TNM=Special High Strength

NOTE: Discard Key which may come standard with most motors and **use only the key included in this kit.**

Center raised pilot guide on the **Adapter Plate** assures proper alignment of pump and engine. Before mounting pump onto engine inspect engine for **recessed seal and bearing guide** to permit adapter to completely seat into recess and four bosses to be flush with engine face.

INTEGRAL UNLOADER

SPECIFICATIONS

	U.S. Measure	Metric Measure
Flow.....	3.0 gpm	(11.4 lpm)
PSI Range.....	100 2850 psi	(7 196 bar)
Inlet Port	3/4" GHF	(3/4" GHF)
Discharge Port	M18 x 1.0	(M18 x 1.0)

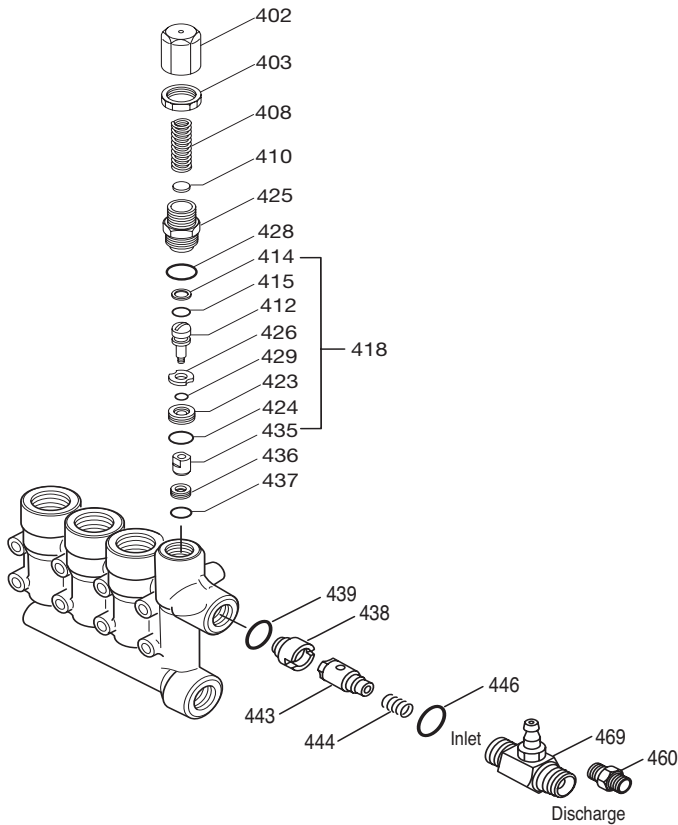

PARTS LIST

ITEM	PN	MATL	DESCRIPTION	QTY.
402	547798	BB	Cap, Adjusting	1
403	45070	BB	Nut, Lock (M18 x 1)	1
408	32094	STZP R	Spring, Pressure	1
410	549352	STCP R	Retainer, Spring	1
412	45694	S	Stem, Piston	1
414	20184	PTFE	Back up Ring, Piston Stem	1
415	14190	NBR	O Ring, Piston Stem 70D	1
418	811528	BB	Assy, Piston (Incls: 412,414,415,423,424,426,429,435)	1
423	46249	BB	Retainer, Valve	1
424	13966	NBR	O Ring, Valve Retainer (Outer) 70D	1
425	547799	BB	Retainer, Piston	1
426	46250	S	Washer	1
428	26133	NBR	O Ring, Piston Retainer 80D	1
429	17399	NBR	O Ring, Valve Retainer (Inner) 80D	1
435	547800	S	Valve	1
436	49664	S	Seat	1
437	13963	NBR	O Ring, Seat 70D	1
438	46254	NY	Seat, Check Valve	1
439	13963	NBR	O Ring, Check Valve Seat 70D	1
443	541060	BB	Valve, Check w/O Ring	1
444	45924	S	Spring	1
446	26133	NBR	O Ring, Body 80D	1
460	107681	BB	Fitting, Discharge (3/8" NPTM)	1
468	31767	NBR	Kit, O Ring (Incls:414,415,424,428,429,437,439,446)	1
	31465	NBR	Kit, Repair (Incls:412,414,415,423,424,425,426,428,429,435)	1
469	7332	BB	Injector, Chemical Fixed	1

Italics are optional items. R Components comply with RoHS Directive.

MATERIAL CODES (Not Part of Part Number):

BB=Brass NBR=Medium Nitrile (Buna N) NY=Nylon

PTFE=Pure Polytetrafluoroethylene S=304SS STCP=Steel/Chrome Plated

STZP=Steel/Zinc Plated

UNLOADER TYPE

An integral unloader with built-in by-pass is part of the discharge manifold to provide system pressure regulation and pump protection. This pump also includes a fixed chemical injector for chemical application.

OPERATION:

Pump should be purged of air before commencing operation. Liquid must flow through the pump without discharge restriction to assure full system pressure is reached.

Install a pressure gauge close to the manifold head of the pump to assist in setting system pressure and to periodically monitor system pressure.

Setting and adjusting the regulator pressure must be done with the system turned on. Start the system with the unloader backed off to the lowest pressure setting (counterclockwise direction). Squeeze the trigger and read the pressure on the gauge at the pump. Do not read pressure at the gun or nozzle. If more pressure is desired, turn adjusting cap one quarter turn in a clockwise direction. Squeeze the trigger and read the pressure. Repeat this process until the desired system pressure is reached. Thread locking nut up to adjusting cap.

NOTE: Pressure is not set at the factory.

SERVICE:

The unloader should be serviced on the same schedule as the seals in the pump. Refer to 3DNX Service Manual for start-up, servicing of seals and valves, torque requirements and diagnosis and maintenance chart.

7332 FIXED CHEMICAL INJECTOR

SPECIFICATIONS

	U.S. Measure	Metric Measure
Flow.....	3.0 gpm	(11.4 lpm)
Nozzle Orifice.....	2.1 mm	(2.1 mm)
Hose Barb	1/4"	(1/4")
Inlet Port	M18 x 1.0	(M18 x 1.0)
Discharge Port	3/8" NPTM	(3/8" NPTM)
Weight	5.3 oz.	(0.15kg)
Dimensions	2 x 1 x 1.75"	(52 x 25 x 45 mm)

CHEMICAL INJECTOR PERFORMANCE CHART

Orifice Size	Maximum Injecting Pressure	Maximum Chemical Draw	Pressure Drop Across Injector At System Pressure (2850 psi)
2.1 mm	250 psi	37.2 oz/min	141 psi

Optimum performance of chemical injector occurs with 35 ft. high pressure hose and a minimum 3/8" I.D. The type of hose, extended lengths, reduced I.D. and fittings may create back pressure in excess of the low pressure nozzle rating and prevent the injector from drawing chemical. See hose friction loss Chart in Service Manual. **Deduct hose friction loss from above low psi nozzle. Contact Cat Pumps for assistance with other options.**

CAUTION: Deduct the pressure drop shown in the performance chart from your desired system pressure to arrive at the maximum high pressure nozzle rating. This is essential to avoid over-pressurizing the pump.

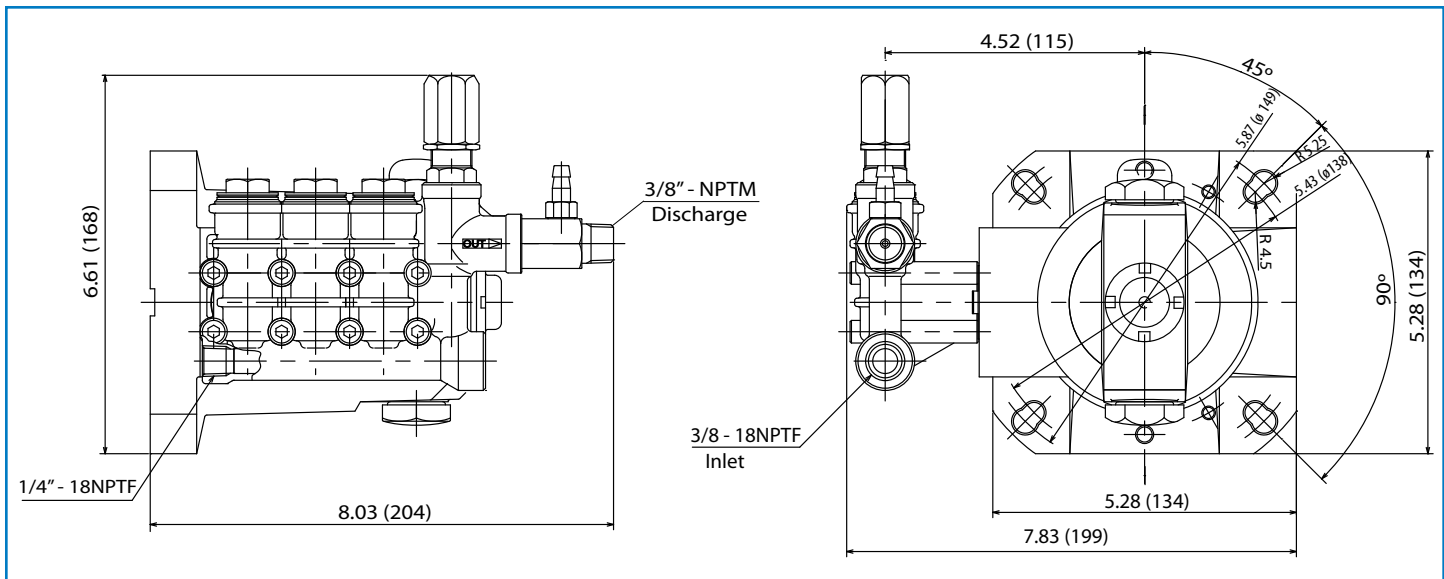

Models 3DNX25GSI, 3DNX27GSI

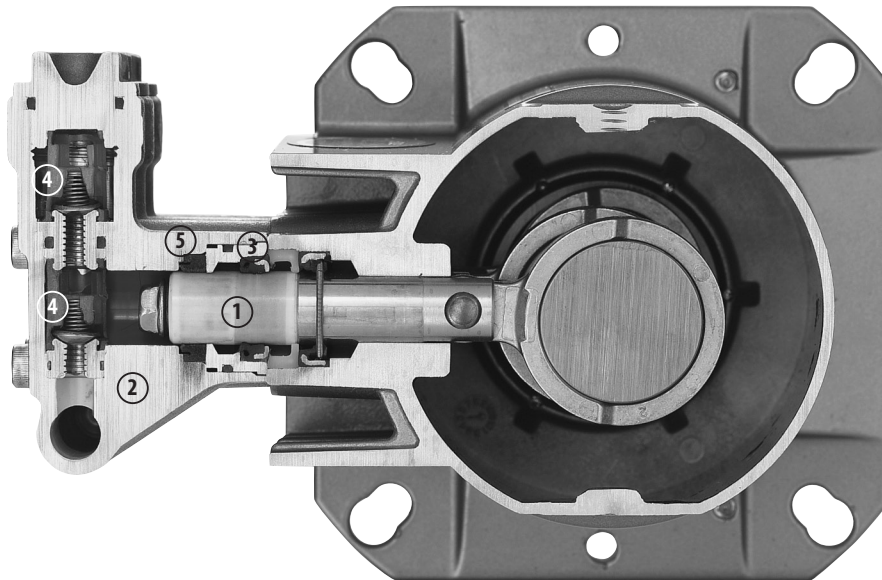

- 1 Special, concentric, high-density, polished solid ceramic **plungers** provide a true wear surface and extended seal life.
- 2 High tensile strength, forged brass **manifold head** with built-in integral unloader and eight mounting screws for exceptional strength.
- 3 100% wet **seal** design adds to service life by allowing pumped liquids to cool and lubricate on both sides.
- 4 Stacked **Valve assemblies** include stainless steel valves, seats and springs to provide corrosion-resistance, ultimate seating and extended life.
- 5 Unique design and specially formulated **V-Packings** offer unmatched performance and seal life.



CAT PUMPS
 1681 - 94TH LANE N.E. MINNEAPOLIS, MN 55449-4324
 PHONE (763) 780-5440 — FAX (763) 780-2958
 e-mail: techsupport@catpumps.com
 www.catpumps.com