

Gas engine must be purchased separately.

PUMP FEATURES

- Triplex plunger design provides a smooth liquid flow.
- Specially formulated Hi-Pressure Seals and concentric solid ceramic plungers assure true wear surface and extended seal life.
- Stacked valve design for ease in servicing.
- Ultra-compact, hollow-shafted pump for direct mounting to gas engine.
- Integral Regulating Unloader with built-in by-pass standard on all units to assure system pressure control and pump protection.
- Fixed chemical injector standard on all units offers cleaning flexibility.
- Swivel garden hose fitting with filter screen for easy inlet connection.

⚠ CAUTIONS AND WARNINGS

All High Pressure Systems require a primary pressure regulating device (i.e. regulator, unloader) and a secondary pressure relief device (i.e. pop-off valve, relief valve). Failure to install such relief devices could result in personal injury or damage to pump or property. CAT PUMPS does not assume any liability or responsibility for the operation of a customer's high pressure system.

Read all CAUTIONS and WARNINGS before commencing service or operation of any high pressure system. The CAUTIONS and WARNINGS are included in each service manual and with each Accessory Data sheet. CAUTIONS and WARNINGS can also be viewed online at www.catpumps.com/cautions-warnings or can be requested directly from CAT PUMPS.

WARRANTY

View the Limited Warranty on-line at www.catpumps.com/warranty.

Direct-Drive Plunger Pump Models

3DX29GSI 3DX30GSI

SPECIFICATIONS

U.S. Measure

Metric Measure

MODEL 3DX29GSI

Flow	2.9 gpm	(10.9 lpm)
Max. Discharge Pressure	2500 psi	(175 bar)
Max. RPM.....	3450 rpm	(3450 rpm)
Stroke	0.232"	(5.9 mm)

MODEL 3DX30GSI

Flow	3.0 gpm	(11.4 lpm)
Max. Discharge Pressure	2500 psi	(175 bar)
Max. RPM.....	3450 rpm	(3450 rpm)
Stroke	0.244"	(6.2 mm)

COMMON PUMP SPECIFICATIONS

Inlet Pressure Range	Flooded to 60 psi	(Flooded to 4 bar)
Bore	0.630"	(16 mm)
Max. Liquid Temperature	140°F	(60°C)
Above 130°F call CAT PUMPS for inlet conditions and elastomer recommendations.		
Crankcase Capacity	8.5 oz.	(0.25 l)
Inlet Port (1)	3/4" GHF	(3/4" GHF)
Discharge Port (1).....	M18x1.0	(M18x1.0)
Chemical Discharge Port (1)	3/8" NPTM	(3/8" NPTM)
Chemical Injection Barb.....	8/32" UNF	(8/32" UNF)
Shaft Diameter	3/4"	(19.0 mm)
Weight	10.7 lbs.	(4.9 kg)
Dimensions.....	7.99 x 7.75 x 6.29"	(203x197x160 mm)

ELECTRIC HORSEPOWER REQUIREMENTS

MODEL	FLOW		PRESSURE					RPM
			psi 1000	psi 1200	psi 1500	psi 2000	psi 2500	
	U.S. gpm	lpm	bar 70	bar 85	bar 105	bar 140	bar 175	
3DX29GSI	2.9	10.9	1.9	2.4	3.0	4.0	5.0	3450
3DX30GSI	3.0	11.4	2.1	2.5	3.1	4.1	5.2	3450

DETERMINING THE PUMP R.P.M. $\frac{\text{Rated gpm}}{\text{Rated rpm}} = \frac{\text{"Desired" gpm}}{\text{"Desired" rpm}}$

DETERMINING THE REQUIRED H.P. $\frac{\text{gpm x psi}}{1460} = \text{Electric Brake H. P. Required}$

Note: Consult engine manufacturer when using gas or diesel engine. Refer to pump **Service Manual** for repair procedure and additional technical information.

"Customer confidence is our greatest asset"

EXPLODED VIEW

October 2010

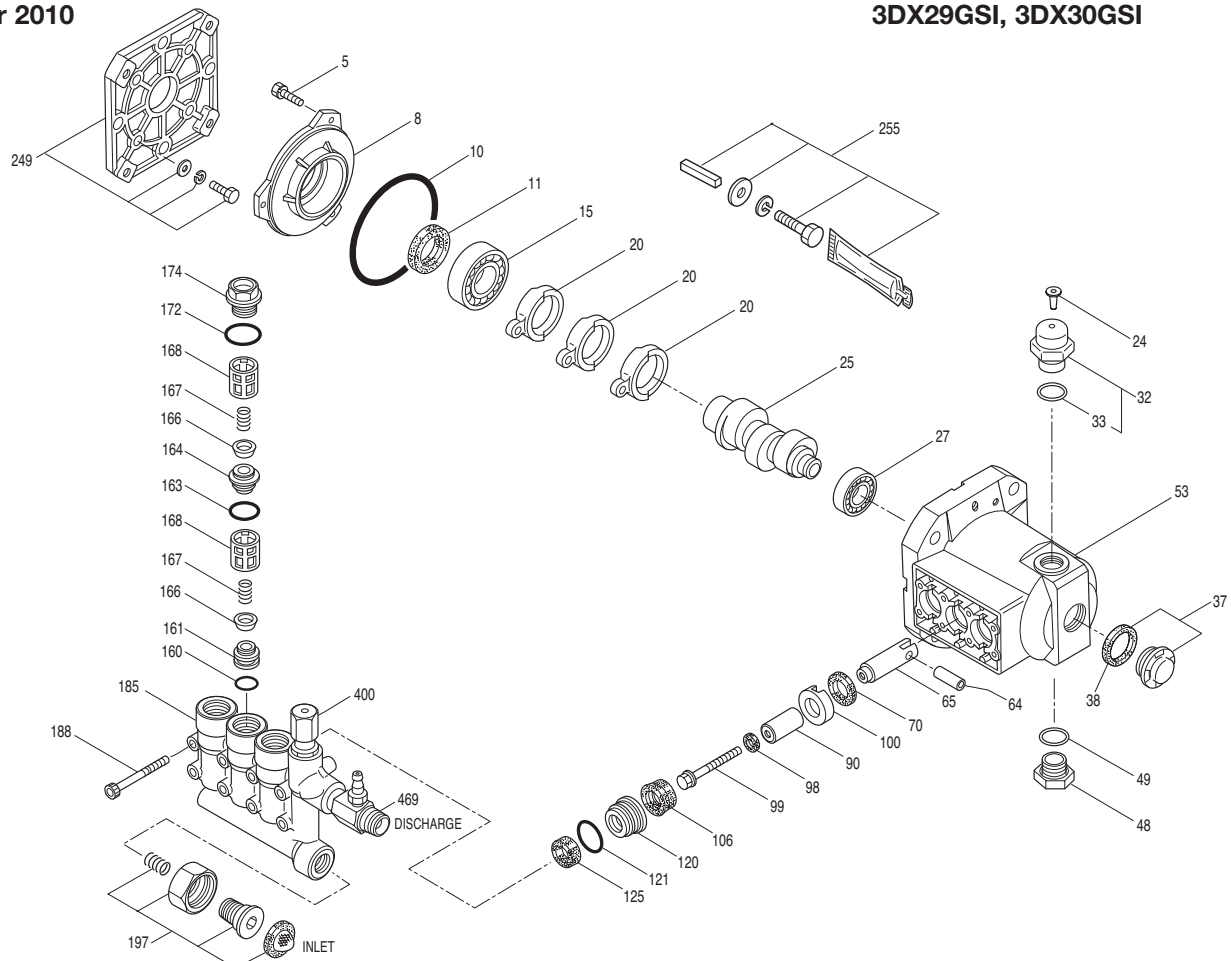

3DX PLUNGER PUMP MODEL

3DX29GSI, 3DX30GSI

PARTS LIST

ITEM	PN	MATL	DESCRIPTION	QTY	ITEM	PN	MATL	DESCRIPTION	QTY
5	549360	STCP R	Screw, HHC Sems (M6x14)	3	125	547157	SNG	Seal, HPS w/S	3
8	547153	AL	Cover, Bearing [4/05]	1	125	547157	SNG	Seal, HPS w/S	3
10	14041	NBR	O-Ring, Bearing Cover - 70D	1	160	13965	NBR	O-Ring, Inlet Valve Seat - 70D	3
11	55337	NBR	Seal, Oil - 70D	1	161	545177	S	Seat, Inlet	3
15	14488	STL	Bearing, Ball	1	163	19285	NBR	O-Ring, Discharge Seat - 70D	3
20	547048	TNM	Rod, Connecting	3	164	545178	S	Seat, Discharge [1/04]	3
24	549608	LDPE	Plug, Oil Cap	1	166	46764	S	Valve	6
25	547946 CM		Crankshaft, 3450 RPM, 3/4", 5.9 mm [01/04]	1	167	46865	S	Spring	6
	548196 CM		Crankshaft, 3450 RPM, 3/4", 6.2 mm [01/04]	1	168	543988	PVDF	Retainer, Spring	6
27	56084	STL	Bearing, Ball [11/03]	1	172	142807	NBR	O-Ring, Plug - 90D	3
32	547961	RTP	Cap, Oil Filler w/O-Ring [01/04]	1	174	46759	BB	Plug, Valve (M20x1.5)	3
33	14179	NBR	O-Ring, Oil Filler Cap - 70D	1		35759	BB	Plug, Valve w/1/4" NPT Port for Accessory	1
37	92241	—	Gauge, Bubble Oil w/Gasket	1	185	† 49523	BB	Head, Manifold w/Integral Unloader Body	1
38	44428	NBR	Gasket, Flat Flex, Oil Gauge - 80D	1	188	542406	STZP	Screw, HSH (M6x60)	8
48	44842	NY	Plug, Drain	1		549357	STCP R	Screw, HSH (M6x60)	8
49	14179	NBR	O-Ring, Drain Plug - 70D	1	197	941516	BB	Assy, GH, 3/8" NPTM (Not Included on 3DX29GSI)	1
53	548062	AL	Crankcase [02/05]	1		—	—	Nut, Swivel (3/4" FGH)	1
64	46229	STL	Pin, Crosshead	3		—	—	Fitting, (3/8" NPTM)	1
65	542402	BB	Rod, Plunger	3		—	—	Screen, Inlet	1
70	47215	NBR	Seal, Oil - 70D	3		—	—	Spring	1
90	542403	CC	Plunger (M16x27)	3	249	30520	—	Assy, Adapter Mount, Standard, GAS	1
98	46730	NBR	Washer, Seal - 90D	3	255	30516	STZP	Assy, Bolt Mount, GAS	1
99	542405	S	Retainer, Plunger (M6x35)	3	300	30530	NBR	Kit, Seal (Incls: 98,106,121,125)	1
100	46233	D	Retainer, Seal	3	310	33057	NBR	Kit, Valve (Incls: 160,161,163,164,166,167,168,172)	1
106	48222	NBR	Seal, LPS w/S-Spg	3	400	—	—	Unloader, Modular (See Individual Parts)	1
120	547357	BB	Case, Seal	3	469	7232	BB	Injector, Chemical Fixed - 3DX30GSI	1
121	13976	NBR	O-Ring, Seal Case - 70D	3		7242	BB	Injector, Chemical Fixed - 3DX29GSI	1

Italics are optional items. [] Date of latest production change. † Production parts different than repair parts. R Components comply with RoHS Directive.

View Tech Bulletins 02, 024, 036, 043, 055, 074 and 083 for additional information.

MATERIAL CODES (Not Part of Part Number): AL=Aluminum BB=Brass CC=Ceramic CM=Chrome-moly D=Acetal LDPE=Low Density Polyethylene

NBR=Medium Nitrile (Buna-N) NY=Nylon PVDF=Polyvinylidene Fluoride RTP=Reinforced Composite S=304SS SNG=Special Blend (Buna) STL=Steel

STCP=Steel/Chrome Plated STZP=Steel/Zinc Plated TNM=Special High Strength

NOTE: Discard Key which may come standard with most engines and **use only the key included in this kit.**

Center raised pilot guide on the **Adapter Plate** assures proper alignment of pump and engine. Before mounting pump onto engine inspect engine for **recessed seal and bearing guide** to permit adapter to completely seat into recess and four bosses to be flush with engine face.

INTEGRAL UNLOADER

SPECIFICATIONS	U.S. Measure	Metric Measure
Flow	3.0 gpm	(11.4 lpm)
PSI Range	100-2500 psi	(7-175 bar)
Inlet Port	3/4" GHF	(3/4" GHF)
Discharge Port	M18x1.0	(M18x1.0)

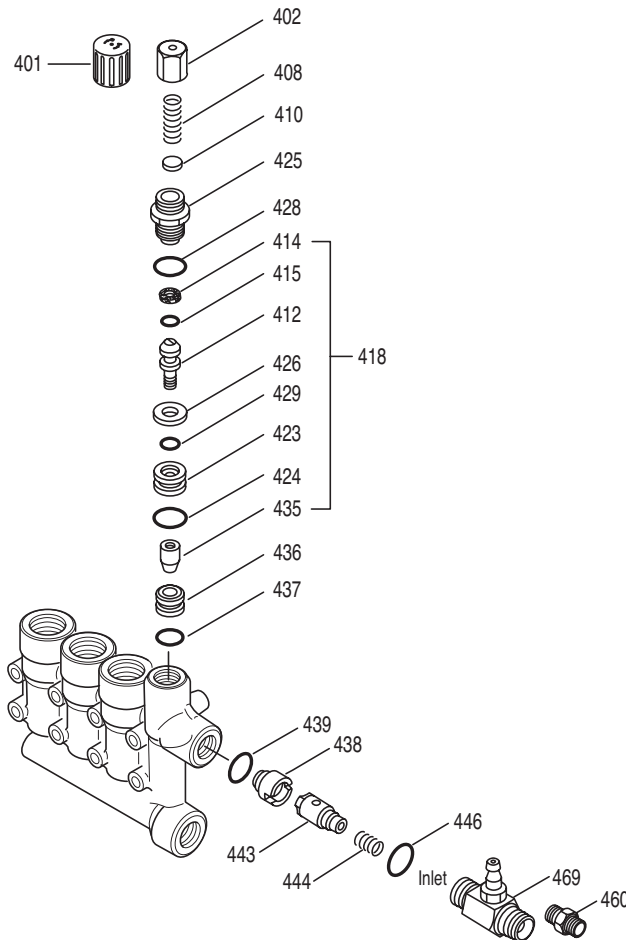

PARTS LIST

ITEM	PN	MATL	DESCRIPTION	QTY.
401	32088	NY	Handle, Adjusting	1
402	46570	BB	Cap, Adjusting	1
403	45070	BB	Nut, Lock (Not Shown) 3DX29GSI ONLY	1
408	33394	STZP R	Spring, Pressure	1
410	549352	STCP R	Retainer, Spring	1
412	46251	BB	Stem, Piston	1
414	28338	PTFE	Back-up-Ring, Piston Stem	1
415	22056	NBR	O-Ring, Piston Stem - 70D	1
418	548230	BB	Assy, Piston (Incls: 412,414,415,423,424,426,429,435)	1
423	46249	BB	Retainer, Valve	1
424	13966	NBR	O-Ring, Valve Retainer (Outer) - 70D	1
425	46248	BB	Retainer, Piston	1
426	46250	S	Washer	1
428	13969	NBR	O-Ring, Piston Retainer - 70D	1
429	17399	NBR	O-Ring, Valve Retainer (Inner) - 80D	1
435	547969	S	Valve	1
436	548075	S	Seat	1
437	13963	NBR	O-Ring, Seat - 70D	1
438	46254	NY	Seat, Check Valve	1
439	13963	NBR	O-Ring, Check Valve Seat - 70D	1
443	541060	BB	Valve, Check w/O-Ring	1
444	45924	S	Spring	1
446	13969	NBR	O-Ring, Body - 70D	1
460	107681	BB	Fitting, Discharge (3/8" NPTM)	1
468	33099	NBR	Kit, O-Ring (Incls: 414,415,424,428,429,437)	1
-	30378	NBR	Kit, Repair (Incls: 418,428,436,437)	1
469	7232	BB	Injector, Chemical Fixed, 3DX25,27,30GSI	1
	7242	BB	Injector, Chemical Fixed, 3DX29GSI	1

Italics are optional items. R Components comply with RoHS Directive.

MATERIAL CODES (Not Part of Part Number): BB=Brass

NBR=Medium Nitrile (Buna-N) NY=Nylon PTFE=Pure Polytetrafluoroethylene
S=304SS STCP=Steel/Chrome Plated STZP=Steel/Zinc Plated

UNLOADER TYPE

An integral unloader with built-in by-pass is part of the discharge manifold to provide system pressure regulation and pump protection. This pump also includes a fixed chemical injector for chemical application.

OPERATION:

Pump should be purged of air before commencing with operation. Liquid must flow through the pump without discharge restriction to assure full system pressure is reached

Install a pressure gauge close to the manifold head of the pump to assist in setting system pressure and to periodically monitor system pressure.

Setting and adjusting the unloader pressure must be done with the system turned on. Start the system with the unloader backed off to the lowest pressure setting (counterclockwise direction). Squeeze the trigger and read the pressure on the gauge at the pump. Do not read pressure at the gun or nozzle. If more pressure is desired, release the trigger, turn adjusting cap one quarter turn in a clockwise direction. Squeeze the trigger and read the pressure. Repeat this process until the desired system pressure is reached. Thread locking nut up to adjusting cap (model 3DX29GSI only).

NOTE: Pressure is not set at the factory.

SERVICE:

The unloader should be serviced on the same schedule as the seals in the pump. Refer to 3DX Service Manual for start-up, servicing of seals and valves, torque requirements and diagnosis and maintenance chart.

FIXED CHEMICAL INJECTOR

SPECIFICATIONS	U.S. Measure	Metric Measure
Model 7232		
GPM	3.0 gpm	(11.4 lpm)
Nozzle Orifice	2.1 mm	(2.1 mm)
Model 7242		
GPM	2.9 gpm	(10.9 lpm)
Nozzle Orifice	2.0 mm	(2.0 mm)
Common Specifications		
Hose Barb	1/4"	(1/4")
Tapped Barb	8/32" UNF	(8/32" UNF)
Inlet Port	M18x1.0	(M18x1.0)
Discharge Port	3/8" NPTM	(3/8" NPTM)
Weight	5.3 oz.	(0.15 kg)
Dimensions	2 x 1 x 1.75"	(52 x 25 x 45 mm)

CHEMICAL INJECTOR PERFORMANCE CHART

Orifice Size	Injector Model	Maximum Injecting Pressure	Maximum Chemical Draw	Pressure Drop Across Injector At System Pressure (2500 psi)
2.1 mm	7232	250 PSI	37.2 oz/min	141 psi
2.0 mm	7242	280 PSI	35.3 oz/min	148 psi

Optimum performance of chemical injector occurs with a 35 ft. high pressure hose and a minimum 3/8" I.D. The type of hose, extended lengths, reduced I.D. and fittings may create back pressures in excess of the low pressure nozzle rating and prevent the injector from drawing chemical. See Hose Friction Loss Chart in Service Manual. Deduct hose friction loss from above low PSI Nozzle. Contact CAT PUMPS for assistance with other options.

CAUTION: Deduct the pressure drop shown in the performance chart from your desired system pressure to arrive at the maximum high pressure nozzle rating. This is essential to avoid over-pressurizing the pump.

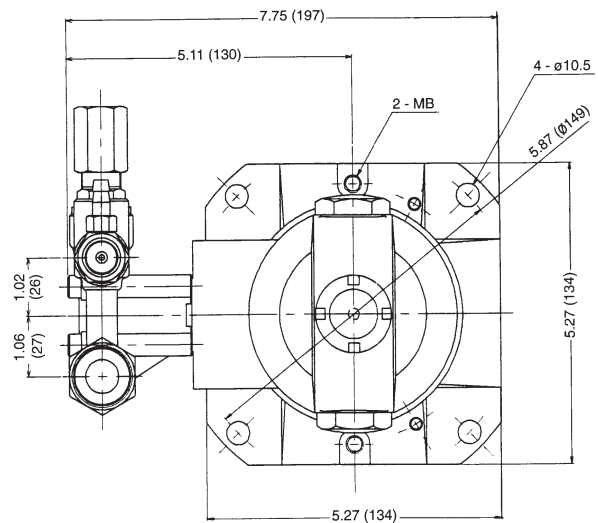
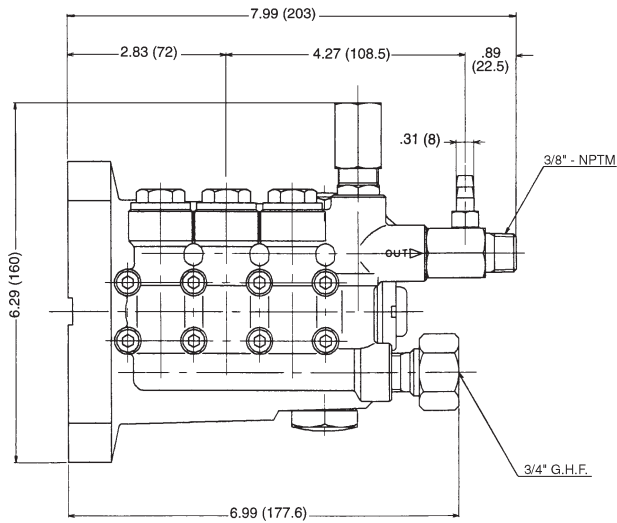

Models 3DX29GSI, 3DX30GSI

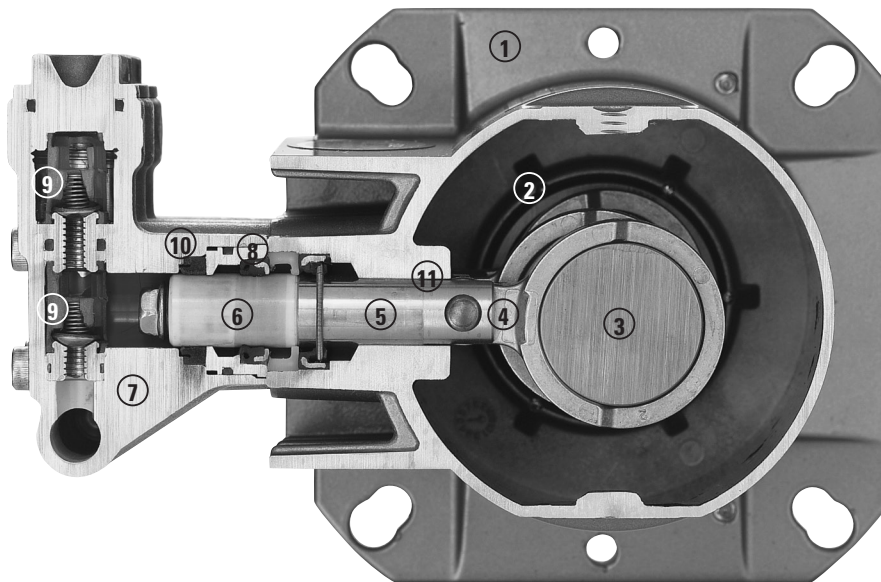

- 1 Die cast flange-style aluminum **crankcase** means high strength, lightweight, and excellent tolerance control.
- 2 Heavy-duty dual crankshaft **bearings** provide extended drive-end life.
- 3 Chrome-moly **crankshaft** provides unmatched strength and surface hardness for long life.
- 4 High strength **connecting rods** assure durability and bearing quality.
- 5 Strong brass **plunger rods** with chrome-moly crosshead pins.
- 6 Special, concentric, high-density, polished solid ceramic **plungers** provide a true wear surface and extended seal life.
- 7 High tensile strength, forged brass **manifold head** with built-in integral unloader and eight mounting screws for exceptional strength.
- 8 100% wet **seal** design adds to service life by allowing pumped liquids to cool and lubricate on both sides.
- 9 Stacked **valve assemblies** include stainless steel valves, seats and springs to provide corrosion-resistance, ultimate seating and extended life.
- 10 Unique design and specially formulated **Hi-Pressure Seals** offer unmatched performance and seal life.
- 11 **Crossheads** are 360° supported for uncompromising alignment.

World Headquarters

CAT PUMPS

1681 - 94th Lane N.E. Minneapolis, MN 55449 - 4324

Phone (763) 780-5440 — FAX (763) 780-2958

e-mail: techsupport@catpumps.com

www.catpumps.com

International Inquiries

FAX (763) 785-4329

e-mail: intlsales@catpumps.com



The Pumps with Nine Lives

CAT PUMPS (U.K.) LTD.

1 Fleet Business Park, Sandy Lane, Church Crookham

FLEET, Hampshire, GU52 8BF, England

Phone Fleet 44 1252-622031 — Fax 44 1252-626655

e-mail: sales@catpumps.co.uk www.catpumps.co.uk

N.V. CAT PUMPS INTERNATIONAL S.A.

Heiveldekens 6A, B-2550 Kontich, Belgium

Phone 32-3-450.71.50 — Fax 32-3-450.71.51

e-mail: cpi@catpumps.be www.catpumps.be

CAT PUMPS DEUTSCHLAND GmbH

Buchwiese 2, D-65510 Idstein, Germany

Phone 49 6126-9303 0 — Fax 49 6126-9303 33

e-mail: catpumps@t-online.de www.catpumps.de