

Gas engine or electric motor must be purchased separately.

## Direct-Drive Plunger Pumps

**Gas Model**            **3SP30G11**  
**Electric Model**      **3SP35GEI**

### FEATURES

- Triplex plunger design provides a smooth liquid flow.
- Specially formulated Hi-Pressure Seals together with concentric, polished Ceramic Plungers assure maximum seal life.
- Compact, hollow shafted pump for direct mounting to either 1" gas or 3/4" electric shaft. Eliminates the need for pulleys, belts or gearboxes.
- Regulating Unloader mounts directly onto pump for system pressure control and pump protection.
- Stacked valve design for ease in servicing.
- Fixed Chemical Injector for cleaning flexibility.

#### **⚠ WARNING**

All systems require both a primary pressure regulating device (i.e., regulator, unloader) and a secondary pressure safety relief device (i.e., pop-off valve, safety valve). Failure to install such relief devices could result in personal injury or damage to the pump or to system components. CAT PUMPS does not assume any liability or responsibility for the operation of a customer's high pressure system.

### SPECIFICATIONS

U.S. Measure

Metric Measure

#### MODEL 3SP30G11

Flow.....3.0 GPM (11.4 L/M)  
 Pressure Range .....100 to 3000 PSI (7 to 210 BAR)  
 Stroke.....0.315" (8.0 mm)  
 Max. RPM .....3400 RPM (3400 RPM)

#### MODEL 3SP35GEI

Flow.....3.5 GPM (13.2 L/M)  
 Pressure Range .....100 to 2500 PSI (7 to 175 BAR)  
 Stroke.....0.346" (8.8 mm)  
 Max. RPM .....3450 RPM (3450 RPM)

#### COMMON PUMP SPECIFICATIONS

Inlet Pressure Range .....Flooded to 60 PSI (Flooded to 4 BAR)  
 Bore.....0.551" (14 mm)  
 Shaft Diameter (Hollow - Gas) .....1" (25.4 mm)  
 Shaft Diameter (Hollow - Elec.) .....3/4" (19 mm)  
 Max. Liquid Temperature .....104°F (40°C)  
 Crankcase Capacity .....10.15 oz. (0.30 L)  
 Inlet Ports (2).....3/8" NPTF (3/8" NPTF)  
 Discharge Ports (2) .....3/8" NPTF (3/8" NPTF)  
 Weight.....11.35 lbs. (5.15 kg)  
 Dimensions (Pump Only) .....5.28 x 7.80 x 8.03" (134 x 198 x 204 mm)

### HORSEPOWER REQUIREMENTS

MODEL	FLOW		PRESSURE			RPM
			PSI 2000	PSI 2500	PSI 3000	
	U.S. GPM	L/M	BAR 140	BAR 175	BAR 210	
<b>3SP30G11</b>	3.0	11.4	4.1	5.1	6.2	3400
<b>3SP35GEI</b>	3.5	13.2	4.8	6.0	N/A	3450

See complete Drive Packages [Incls: Pulleys, Belts, Hubs, Key] Tech Bulletin 003. Refer to pump **Service Manual** for repair procedure, additional technical information and **pump warranty**.

*“Customer confidence is our greatest asset”*

# EXPLODED VIEW

November 2004

# 3SP PLUNGER PUMPS

Electric Model: 3SP35GEI

Gas Model: 3SP30G1I

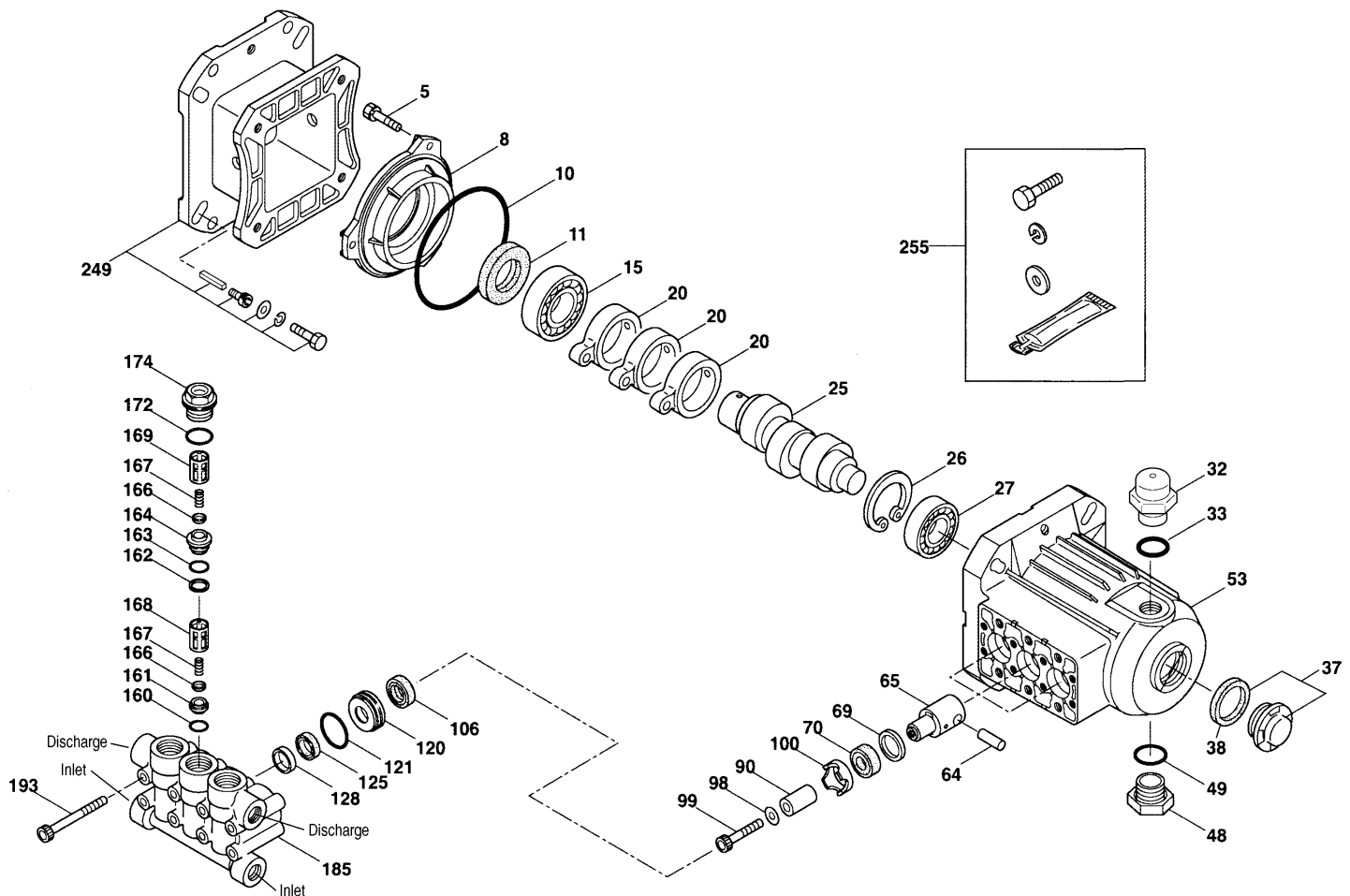

## PARTS LIST

ITEM	P/N	MATL	DESCRIPTION	QTY	ITEM	P/N	MATL	DESCRIPTION	QTY
5	547161	STCP	Screw, HH (M6X14)	3	162	48361	D	Back-up-Ring, Discharge Seat	3
8	547084	AL	Cover, Bearing	1	163	43358	NBR	O-Ring, Discharge Seat - 70D	3
10	14041	NBR	O-Ring, Bearing Cover - 70D	1	164	547076	S	Seat, Discharge	3
11	46419	NBR	Seal, Oil - 70D	1	166	547098	S	Valve	6
15	547112	STL	Bearing, Ball, Inner	1	167	46865	S	Spring	6
20	547020	TNM	Rod, Connecting Assy	3	168	543988	PVDF	Retainer, Spring, Inlet	3
25	547136	FCM	Crankshaft, 3400 RPM, 1", 8.0 mm	1	169	547441	PVDF	Retainer, Spring, Discharge	3
	547148	FCM	Crankshaft, 3450 RPM, 3/4", 8.8 mm	1	172	142807	NBR	O-Ring, Valve Plug - 90D	3
26	12385	STL	Ring, Retaining	1	174	547078	BB	Plug, Valve (M22x1.5)	3
27	15710	STL	Bearing, Ball, Outer	1	185	546962	FBB	Head, Manifold	1
32	547961	RTP	Cap, Oil Filler [1/04]	1	193	542406	STZP	Screw, HSH (M6x60)	8
33	14179	NBR	O-Ring, Oil Filler Cap - 70D	1	249	31643	—	Mount, Adapter Assy, Gas	1
37	92241	—	Gauge, Oil, Bubble w/Gasket - 80D	1		547085	AL	Flange, Adapter	1
38	44428	NBR	Gasket, Flat, Oil Gauge - 80D	1		817033	STCP	Screw, Hex (M8x35)	4
48	44842	NY	Plug, Drain	1		45217	STL	Key (1/4"x1/4"x2-1/2")	1
49	14179	NBR	O-Ring, Drain Plug - 70D	1		87788	STZP	Screw, Set (M5x8)	1
53	547111	AL	Crankcase	1	249	31657	—	Mount, Adapter Assy, Electric	1
64	16948	CM	Pin, Crosshead	3		547085	AL	Flange, Adapter	1
65	547081	SZZ	Rod, Plunger	3		817033	STCP	Screw, Hex (M8x35)	4
69	20017	STZP	Washer, Oil Seal	3		547162	STL	Key (3/16"x3/16"x1-1/2")	1
70	25301	NBR	Seal, Oil - 80D	3		547164	STZP	Screw, Set (M4x10)	1
90	547091	CC	Plunger (M14x25.5)	3	255	30514	STZP	Mount, Bolt Assy, Electric/Gas	1
98	547092	CU	Gasket, Plunger Retainer	3		30980	STZP	Washer, Flat (3/8")	4
99	548522	S	Retainer, Plunger (M6x35)	3		30921	STZP	Lockwasher (3/8")	4
100	44869	PVDF	Retainer, Seal	3		34100	STZP	Screw (3/8"-16x1-3/8")	4
106	45188	NBR	Seal, LPS w/S-SPG	3		6106	—	Lubricant, Antiseize	1
120	547093	BB	Case, Seal	3	300	31644	NBR	Kit, Seal (Incls: 98, 106, 121, 125, 128)	1
121	547103	NBR	O-Ring, Seal Case - 70D	3	310	31647	NBR	Kit, Valve (Incls: 160, 161, 162, 163, 164, 166, 167, 168, 169, 172)	1
125	547082	SNG	V-Packing	3					
128	547083	PVDF	Adapter, Male	3	400	7700	BB	Unloader, Modular w/Fixed Chem Injector [11/04]	1
160	17428	NBR	O-Ring, Inlet Seat - 80D	3					
161	547077	S	Seat, Inlet	3					

*Italics are optional items.* [ ] Date of latest production change. See Tech Bulletins 002, 024, 036, 043, 055, 074, 083 and 092 for additional information.  
 MATERIAL CODES (Not Part of Part Number): AL=Aluminum BB=Brass CC=Ceramic CM=Chrome-Moly CU=Copper D=Acetal FBB=Forged Brass  
 FCM=Forged Chrome-Moly NBR=Medium Nitrile (Buna-N) NY=Nylon PVDF=Polyvinylidene Fluoride RTP=Reinforced Composite S=304SS  
 SNG=Special Blend (Buna) STCP=Steel/Chrome Plated STL=Steel STZP=Steel/Zinc Plated SZZ=304SS/Zamak TNM=Special High Strength  
 NOTE: Discard Key which may come standard with most motors and engines and use only the key included in this kit.

# 7700 UNLOADER WITH INJECTOR

Specifications	U.S. Measure	Metric Measure
GPM .....	0.5-7.8 GPM	(1.9-29.5 L/M)
PSI Range .....	100-3145 PSI	(7-220 BAR)
Inlet Port .....	3/8" NPTF	(3/8" NPTF)
Discharge Port .....	3/8" NPTM	(3/8" NPTM)
Weight .....	20.8 oz.	(0.59 kg)
Dimensions .....	3 2 x 1.5 x 4.7"	(81 x 38 x 119.4 mm)

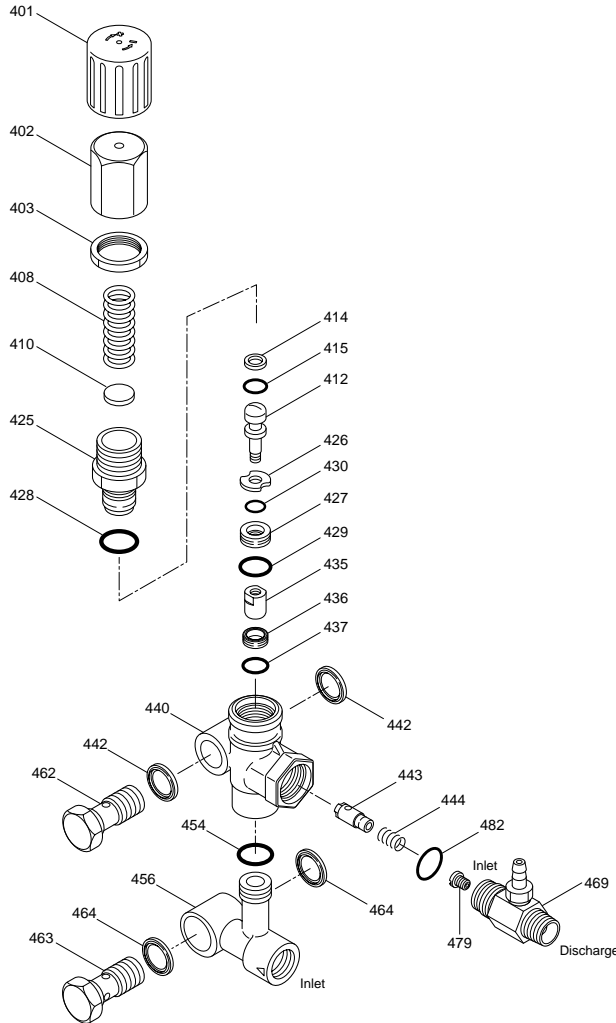

## PARTS LIST

ITEM	P/N	MATL	DESCRIPTION	QTY.
401	547797	NY	Handle, Adjusting	1
402	547798	BB	Cap, Adjusting	1
403	45070	BB	Nut, Lock (M18x1)	1
408	32094	STZP	Spring, Pressure (Silver)	1
410	45862	STZP	Retainer, Spring	1
412	45694	S	Stem, Piston	1
414	20184	PTFE	Back-up-Ring, Stem	1
415	14190	NBR	O-Ring, Stem - 70D	1
425	547799	BB	Retainer, Piston	1
426	46250	S	Washer	1
427	46249	BB	Retainer, Valve	1
428	26133	NBR	O-Ring, Retainer - 80D	1
429	13966	NBR	O-Ring, Retainer - 70D	1
430	17399	NBR	O-Ring, Stem - 80D	1
435	547800	S	Valve/Ball Assembly	1
436	547801	S	Seat	1
437	13963	NBR	O-Ring, Seat - 70D	1
440		FBB	Body	1
442	49121	STL	Washer, Seal 3/8"	2
443	547826	BB	Valve, Check w/NBR O-Ring	1
444	45924	S	Spring, Check Valve	1
454		NBR	O-Ring, Manifold - 70D	1
456		BB	Manifold, Lower Body	1
462	49120	BB	Screw, Flo-Thru, 3/8"	1
463	547806	BB	Screw, Flo-Thru, 3/8"	1
464	49121	STL	Washer, Seal 3/8"	2
468	31707	NBR	Kit, O-Ring <i>(Incls: 414, 415, 428, 429, 430, 437, 454, 482)</i>	1
469	7332	BB	Fixed Chemical Injector (M18x1)	1
482	13969	NBR	O-Ring, Body - 70D	1

*Italics are optional items.*

MATERIAL CODES (Not Part of Part Number): BB=Brass FBB=Forged Brass  
 NBR=Medium Nitrile (Buna-N) NY=Nylon PTFE=Pure Polytetrafluoroethylene  
 S=304SS STZP=Steel/Zinc Plated

## INSTALLATION:

A Regulating Unloader with Chemical Injector comes with each 3SP pump to provide system pressure regulation, pump protection and metered chemical application. The Unloader is mounted directly onto the pump.

## OPERATION:

Set the unloader while the high pressure system is turned on. Adjust in small increments until the desired system pressure is reached. Install a pressure gauge to check pressure during start-up and periodically during operation.

If unit is infrequently used or periodically stored, seals and O-Rings may become dry. Check seals and O-Rings before commencing operation.

The system must be purged before operation (system liquid must flow through the pump without discharge restriction) to assure full system pressure is reached.

**NOTE:** For correct nozzle selection, **read system pressure at the pump. DO NOT READ SYSTEM PRESSURE AT THE HIGH PRESSURE GUN.** Incorrect pressure reading may result in: pump operation at excessive pressures, inconsistent chemical draw or possible damage to the pump or unloader.

## SERVICE:

The unloader should be serviced on the same schedule as your pump. Replacing the O-Rings is generally all that is required. Lubricate the O-Rings for ease in installation and replace all O-Rings included in the kit. Examine the seating surfaces of the seat, ball and valve assembly, and valve stem and replace as needed. Check the spring and replace as needed. Examine the check valve and replace as needed. Thread the adjusting cap onto the unloader and reset system pressure.

Refer to 3SP Service Manual for start up, torque requirements, troubleshooting and servicing the seals and valves.

### CHEMICAL INJECTOR PERFORMANCE CHART

Desired Pump Flow	Orifice Size	Injector Model	Maximum Injecting Pressure	Maximum Chemical Draw	Pressure Drop Across Injector At System Pressure (3000 PSI)
3.0	2.1 mm	7332	163 PSI	35.5 oz/min	200 PSI
3.5	2.1 mm	7332	200 PSI	45.6 oz/min	258 PSI

Optimum performance of chemical injector occurs with a 35 ft. high pressure hose and a minimum 3/8" I.D. The type of hose, extended lengths, reduced I.D. and fittings may create back pressures in excess of the low pressure nozzle rating and prevent the injector from drawing chemical. See Hose Friction Loss Chart in Service Manual. **Deduct hose friction loss from above low PSI Nozzle. Consult CAT PUMPS for assistance with other options.**

**CAUTION:** Deduct the pressure drop shown in the performance chart from your desired system pressure to arrive at the maximum high pressure nozzle rating. This is essential to avoid over-pressurizing the pump.

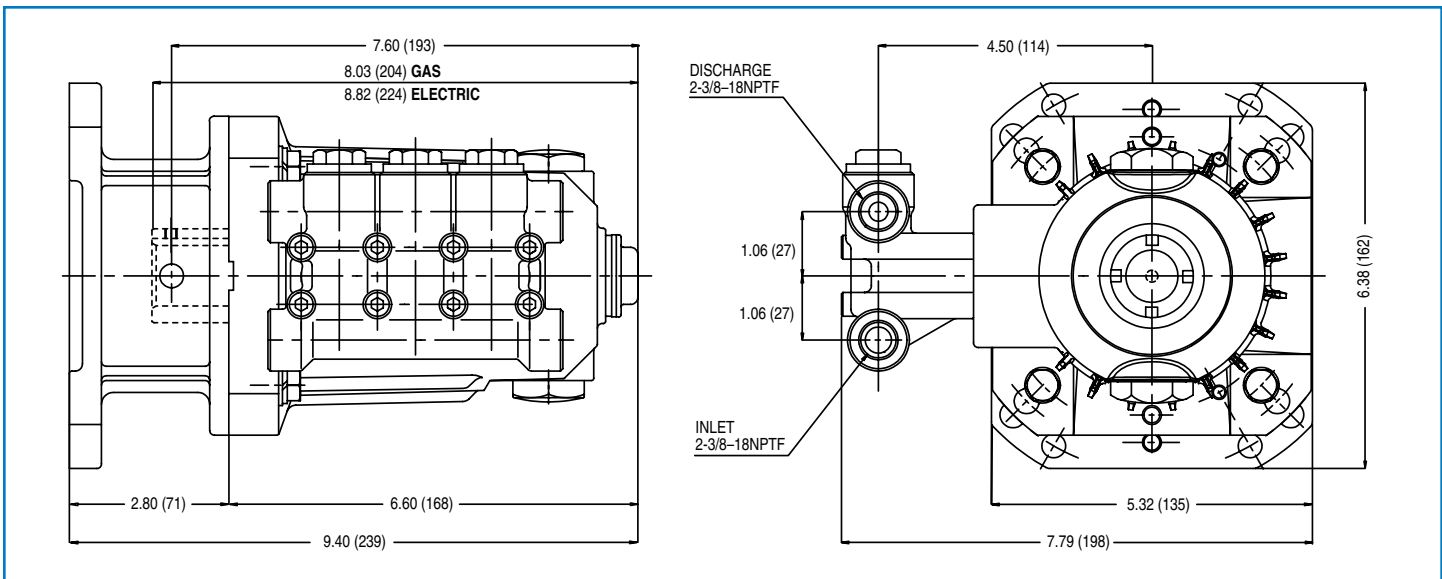

Model 3SP30G11, 3SP35GEI

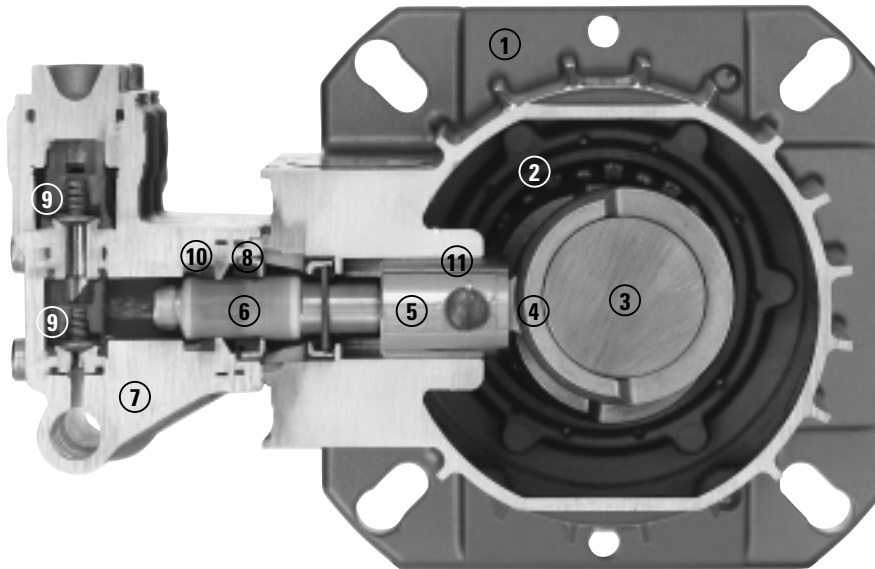

- |   |   |  |
|---|---|--|
| <p><b>1</b> Die cast flange-style aluminum <b>crankcase</b> provides high strength, lightweight, and excellent tolerance control.</p> <p><b>2</b> Heavy-duty dual crankshaft <b>bearings</b> provide extended drive-end life.</p> <p><b>3</b> Chrome-moly <b>crankshaft</b> provides unmatched strength and surface hardness for long life.</p> <p><b>4</b> High strength <b>connecting rods</b> assure durability and bearing quality.</p> | <p><b>5</b> Stainless steel <b>plunger rods</b> with chrom-moly crosshead pins for strength and wear resistance.</p> <p><b>6</b> Special concentric, high-density, polished, solid ceramic <b>plungers</b> provide a true wear surface and extended seal life.</p> <p><b>7</b> High tensile strength, forged brass <b>manifold head</b> with eight mounting screws for exceptional strength.</p> <p><b>8</b> 100% wet <b>seal</b> design adds to service life by allowing pumped liquids to cool and lubricate on both sides.</p> | <p><b>9</b> Stainless steel <b>valves, seats and springs</b> provide corrosion-resistance, positive seating and long life.</p> <p><b>10</b> Unique design and specially formulated <b>Hi-Pressure Seals</b> offer unmatched performance and seal life.</p> <p><b>11</b> <b>Crossheads</b> are 360° supported for uncompromising alignment.</p> |
|---|---|--|

### World Headquarters

CAT PUMPS

1681 - 94th Lane N.E. Minneapolis, MN 55449-4324

Phone (763) 780-5440 — FAX (763) 780-2958

e-mail: techsupport@catpumps.com

www.catpumps.com

### International Inquiries

FAX (763) 785-4329

e-mail: intlsales@catpumps.com



*The Pumps with Nine Lives*

### CAT PUMPS (U.K.) LTD.

1 Fleet Business Park, Sandy Lane, Church Crookham, Fleet

Hampshire GU52 8BF, England

Phone Fleet 44 1252-622031 — Fax 44 1252-626655

e-mail: sales@catpumps.co.uk

### N.V. CAT PUMPS INTERNATIONAL S.A.

Heiveldekens 6A, 2550 Kontich, Belgium

Phone 32-3-450.71.50 — Fax 32-3-450.71.51

e-mail: cpi@catpumps.be www.catpumps.be

### CAT PUMPS DEUTSCHLAND GmbH

Buchwiese 2, D-65510 Idstein, Germany

Phone 49 6126-9303 0 — Fax 49 6126-9303 33

e-mail: catpumps@t-online.de www.catpumps.de