

EXPLODED VIEW

June 2007

3SPX PLUNGER PUMPS

Gas Model: 3SPX30G11

Electric Model: 3SPX35GE1

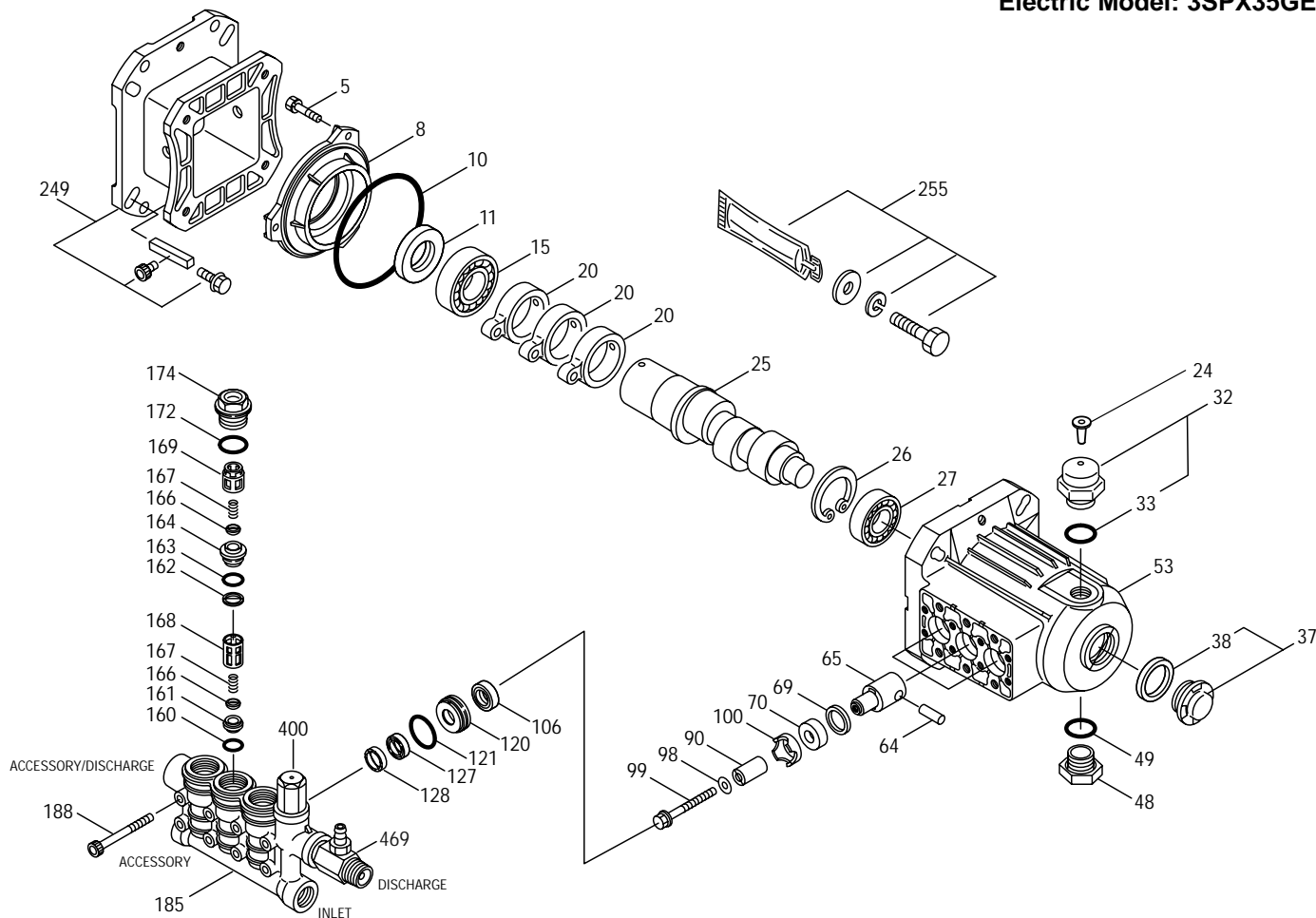

PARTS LIST

ITEM	P/N	MATL	DESCRIPTION	QTY	ITEM	P/N	MATL	DESCRIPTION	QTY
5	547161	STCP	Screw, HHC Sems (M6X14)	3	163	43358	NBR	O-Ring, Discharge Seat - 70D	3
	549360	STCP R	Screw, HHC Sems (M6x14)	3	164	547076	S	Seat, Discharge	3
8	547084	AL	Cover, Bearing	1	166	547098	S	Valve	6
10	14041	NBR	O-Ring, Bearing Cover - 70D	1	167	46865	S	Spring	6
11	125351	NBR	Seal, Oil	1	168	543988	PVDF	Retainer, Spring, Inlet	3
15	547112	STL	Bearing, Ball, Inner	1	169	547441	PVDF	Retainer, Spring, Discharge	3
20	547020	TNM	Rod, Connec ing Assy	3	172	142807	NBR	O-Ring, Valve Plug - 90D	3
24	76045	LDPE	Plug, Oil Cap	1	174	547078	BB	Plug, Valve (M22x1.5)	3
25	548823	FCM	Crankshaft, 3450 RPM, 1", 8.0 mm	1	185	548870	FBB	Head, Manifold w/Integral Unloader Body	1
	547148	FCM	Crankshaft, 3450 RPM, 3/4", 8.8 mm	1	188	542406	STZP	Screw, HSH (M6x60)	8
26	12385	STL	Ring, Retaining	1		549357	STCP R	Screw, HSH (M6x60)	8
27	15710	STL	Bearing, Ball, Outer	1	249	31643	—	Mount, Adapter Assy, Gas	1
32	547961	RTP	Cap, Oil Filler w/O-Ring	1		547085	AL	Flange, Adapter	1
33	14179	NBR	O-Ring, Oil Filler Cap - 70D	1		126764	STCP R	Screw, HH Sems (M8x35)	4
37	92241	—	Gauge, Oil, Bubble w/Gasket - 80D	1		45217	STL	Key (1/4"x1/4"x2-1/2")	1
38	44428	NBR	Gasket, Flat, Oil Gauge - 80D	1		87788	STZP	Screw, HSH Set (M5x8)	1
48	44842	NY	Plug, Drain	1		126761	STCP R	Screw, HSH Set (M5x8)	1
49	14179	NBR	O-Ring, Drain Plug - 70D	1	249	31657	—	Mount, Adapter Assy, Electric	1
53	547111	AL	Crankcase	1		547085	AL	Flange, Adapter	1
64	16948	CM	Pin, Crosshead	3		126764	STCP R	Screw, HH Sems (M8x35)	4
65	548872	BB	Rod, Plunger	3		547162	STL	Key (3/16"x3/16"x1-1/2")	1
69	126259	STCP R	Washer, Oil Seal	3		547164	CM	Screw, Set HSH (M4x10)	1
90	547091	CC	Plunger (M14x25.5)	3	255	30514	STZP	Mount, Bolt Assy, Electric/Gas	1
98	46730	NBR	Washer, Seal - 90D	3		30980	STZP R	Washer, Flat (3/8")	4
99	542405	S	Retainer, Plunger (M6x35)	3		30921	STZP R	Lockwasher (3/8")	4
100	44869	PVDF	Retainer, Seal	3		34100	STZP	Screw, HH (3/8"-16x1-3/8")	4
106	45188	NBR	Seal, LPS w/S-SPG	3		126543	STCP R	Screw, HH (3/8"-16x1-3/8")	4
120	547093	BB	Case, Seal	3		6106	—	Lubricant, Antiseize	1
121	547103	NBR	O-Ring, Seal Case - 70D	3	299	549465	FBB	Head, Complete (Incls: 106-188)	1
127	547082	SNG	V-Packing	3	300	31674	NBR	Kit, Seal (Incls: 98,106,121,127,128)	1
128	547083	PVDF	Adapter, Male	3	310	31647	NBR	Kit, Valve	1
160	17428	NBR	O-Ring, Inlet Seat - 80D	3				(Incls: 160,161,162,163,164,166,167,168,169,172)	
161	547077	S	Seat, Inlet	3	400	—	—	Unloader, Integral (See Individual Parts)	1
162	48361	D	Back-up-Ring, Discharge Seat	3	469	7332	—	Injector, Chemical Fixed	1

Italics are optional items. [] Date of latest production change. R Components comply with RoHS Directive.

See Tech Bulletins 002, 024, 036, 043, 055, 074, 083 and 092 for additional information.

MATERIAL CODES (Not Part of Part Number): AL=Aluminum BB=Brass CC=Ceramic CM=Chrome-Moly D=Acetal FBB=Forged Brass
 FCM=Forged Chrome-Moly LDPE=Low Density Polyethylene BR=Medium Nitrile (Buna-N) NY=Nylon PVDF=Polyvinylidene Fluoride RTP=Reinforced Composite
 S=304SS SNG=Special Blend (Buna) STCP=Steel/Chrome Plated STL=Steel STZP=Steel/Zinc Plated TNM=Special High Strength

NOTE: Discard Key which may come standard with most motors and engines and use only the key included in this kit.

INTEGRAL UNLOADER

Specifications	U.S. Measure	Metric Measure
Flow	3.5 GPM	(13.2 L/M)
PSI Range.....	100-3000 PSI	(7-210 BAR)
Discharge Port	M18 x 1.0	(M18 x 1.0)

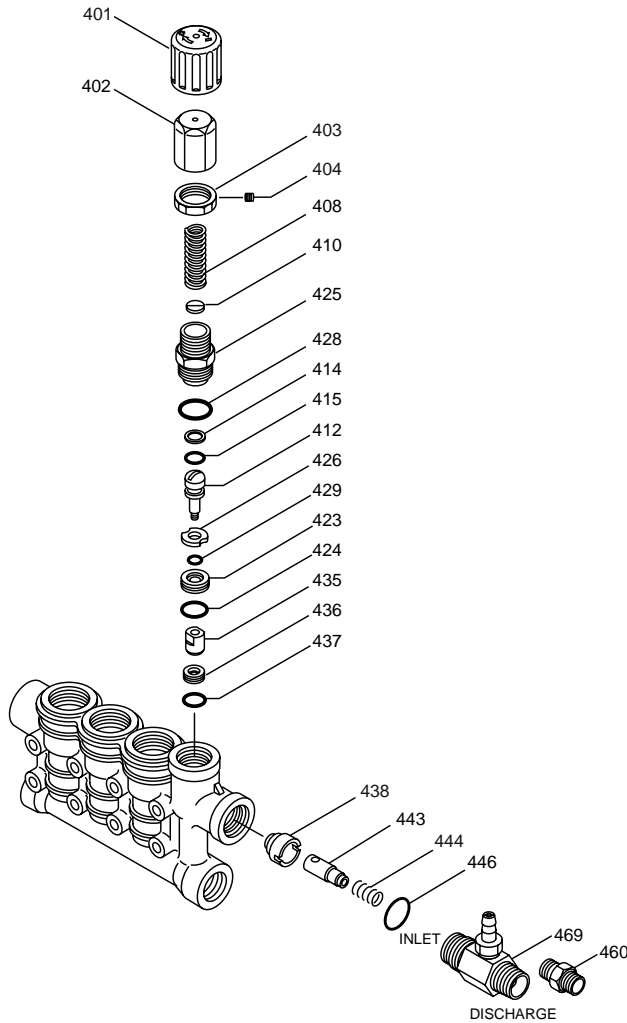

PARTS LIST

ITEM	P/N	MATL	DESCRIPTION	QTY.
401	547797	NY	Handle, Adjusting	1
402	547798	BB	Cap, Adjusting	1
403	548671	BB	Nut, Lock (M18x1)	1
404	548675	STL	Screw, Set (M4x1)	1
408	32094	STZP R	Spring, Pressure	1
410	45862	STZP	Retainer, Spring	1
	<i>549352</i>	<i>STCP R</i>	<i>Retainer, Spring</i>	<i>1</i>
412	45694	S	Stem, Piston (M5)	1
414	20184	PTFE	Back-up-Ring, Piston Stem	1
415	14190	NBR	O-Ring, Piston Stem - 70D	1
423	46249	BB	Retainer, Valve	1
424	13966	NBR	O-Ring, Valve Retainer (Outer) - 70D	1
425	547799	BB	Retainer, Piston	1
426	46250	S	Washer	1
428	26133	NBR	O-Ring, Piston Retainer - 80D	1
429	17399	NBR	O-Ring, Valve Retainer (Inner) - 80D	1
435	547800	S	Valve/Ball Assembly	1
436	547801	S	Seat	1
437	13963	NBR	O-Ring, Seat - 70D	1
438	46254	NY	Seat	1
443	547826	BB	Valve, Check w/NBR O-Ring	1
444	45924	S	Spring, Check Valve	1
446	26133	NBR	O-Ring, Body - 80D	1
460	107681	BB	Fitting, Discharge (3/8" NPTF x M18)	1
468	31767	NBR	Kit, O-Ring <i>(Incls: 414, 415, 424, 428, 429, 437, 446)</i>	1
469	7332	BB	Injector, Fixed Chemical	1

Italics are optional items. R Components comply with RoHS Directive.

MATERIAL CODES (Not Part of Part Number): BB=Brass

NBR=Medium Nitrile (Buna-N) Ny=Nylon PTFE=Pure Polytetrafluoroethylene
S=304SS STL=Steel STCP=Steel/Chrome Plated STZP=Steel/Zinc Plated

UNLOADER TYPE

An integral unloader with built-in by-pass is part of the discharge manifold to provide system pressure regulation and pump protection. This pump also includes a fixed chemical injector for chemical application.

OPERATION:

Pump should be purged of air before commencing with operation. Liquid must flow through the pump only to assure full system pressure is reached.

Install a pressure gauge close to the manifold head of the pump to assist in setting system pressure and to periodically monitor system pressure.

Setting and adjusting the unloader pressure must be done with the system turned on. Start the system with the unloader backed off to the lowest pressure setting (counterclockwise direction). Squeeze the trigger and read the pressure on the gauge at the pump. Do not read pressure at the gun or nozzle. If more pressure is desired, release the trigger, turn adjusting cap one quarter turn in a clockwise direction. Squeeze the trigger and read the pressure. Repeat this process until the desired system pressure is reached. Thread locking nut up to adjusting cap and tighten set screw.

NOTE: Pressure is not set at the factory.

SERVICE:

The unloader should be serviced on the same schedule as the seals in the pump. Refer to 3SPX Service Manual for start-up, servicing of seals and valves, torque requirements and diagnosis and maintenance chart.

7332 FIXED CHEMICAL INJECTOR

SPECIFICATIONS	U.S. Measure	Metric Measure
Flow	3.5 GPM	(13.2 L/M)
Nozzle Orifice	2.1 mm	(2.1 mm)
Hose Barb	1/4"	(1/4")
Tapped Barb	8/32" UNF	(8/32" UNF)
Inlet Port	M18x1.0	(M18x1.0)
Discharge Port	3/8" NPTM	(3/8" NPTM)
Weight	5.3 oz.	(0.15 kg)
Dimensions	2 x 1 x 1.75"	(52 x 25 x 45 mm)

CHEMICAL INJECTOR PERFORMANCE CHART

Desired Pump Flow	Orifice Size	Injector Model	Maximum Injecting Pressure	Maximum Chemical Draw	Pressure Drop Across Injector At System Pressure (3000 PSI)
3.0	2.1 mm	7332	163 PSI	35.5 oz/min	200 PSI
3.5	2.1 mm	7332	200 PSI	45.6 oz/min	258 PSI

Optimum performance of chemical injector occurs with a 35 ft. high pressure hose and a minimum 3/8" I.D. The type of hose, extended lengths, reduced I.D. and fittings may create back pressures in excess of the low pressure nozzle rating and prevent the injector from drawing chemical. See Hose Friction Loss Chart in Service Manual. **Deduct hose friction loss from above low PSI Nozzle. Contact CAT PUMPS for assistance with other options.**

CAUTION: Deduct the pressure drop shown in the performance chart from your desired system pressure to arrive at the maximum high pressure nozzle rating. This is essential to avoid over-pressurizing the pump.

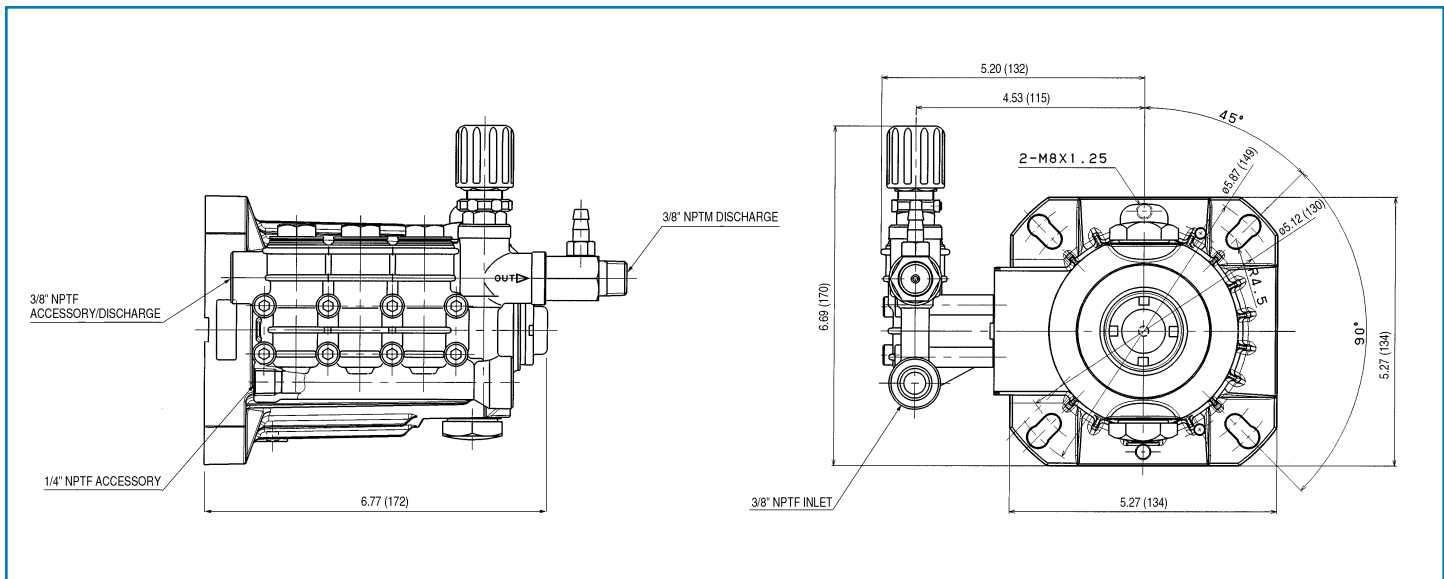

Model 3SPX30G11, 3SPX35GEI

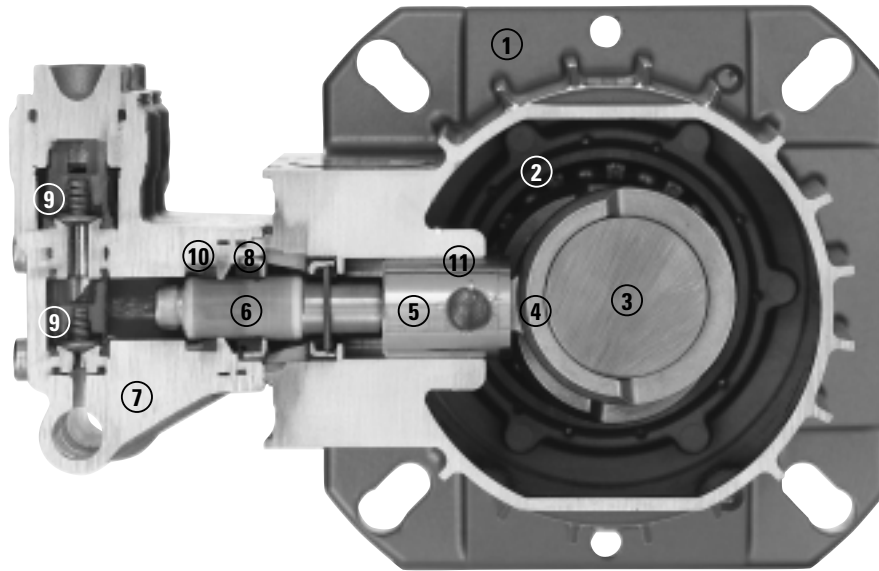

- | | | |
|---|---|---|
| <p>1 Die cast flange-style aluminum crankcase provides high strength, lightweight, and excellent tolerance control.</p> <p>2 Heavy-duty dual crankshaft bearings provide extended drive-end life.</p> <p>3 Chrome-moly crankshaft provides unmatched strength and surface hardness for long life.</p> <p>4 High strength connecting rods assure durability and bearing quality.</p> | <p>5 Stainless steel plunger rods with chrome-moly crosshead pins for strength and wear resistance.</p> <p>6 Special concentric, high-density, polished, solid ceramic plungers provide a true wear surface and extended seal life.</p> <p>7 High tensile strength, forged brass manifold head with built-in integral unloader and eight mounting screws for exceptional strength.</p> <p>8 100% wet seal design adds to service life by allowing pumped liquids to cool and lubricate on both sides.</p> | <p>9 Stacked valve assemblies include stainless steel valves, seats and springs to provide corrosion-resistance, ultimate seating and extended life.</p> <p>10 Unique design and specially formulated V-Packings offer unmatched performance and seal life.</p> <p>11 Crossheads are 360° supported for uncompromising alignment.</p> |
|---|---|---|

World Headquarters

CAT PUMPS

1681 - 94th Lane N.E. Minneapolis, MN 55449-4324

Phone (763) 780-5440 — FAX (763) 780-2958

e-mail: techsupport@catpumps.com

www.catpumps.com

International Inquiries

FAX (763) 785-4329

e-mail: intlsales@catpumps.com



The Pumps with Nine Lives

CAT PUMPS (U.K.) LTD.

1 Fleet Business Park, Sandy Lane, Church Crookham

FLEET, Hampshire, GU52 8BF, England

Phone Fleet 44 1252-622031 — Fax 44 1252-626655

e-mail: sales@catpumps.co.uk

N.V. CAT PUMPS INTERNATIONAL S.A.

Heiveldekens 6A, B-2550 Kontich, Belgium

Phone 32-3-450.71.50 — Fax 32-3-450.71.51

e-mail: cpi@catpumps.be www.catpumps.be

CAT PUMPS DEUTSCHLAND GmbH

Buchwiese 2, D-65510 Idstein, Germany

Phone 49 6126-9303 0 — Fax 49 6126-9303 33

e-mail: catpumps@t-online.de www.catpumps.de