

Gas engine must be purchased separately.

O.E.M. Triplex Plunger Pumps

Models **4HP35G1**
 4HP40G1

SPECIFICATIONS

	U.S. Measure	Metric Measure
MODEL 4HP35G1		
Volume	3.5 GPM	(13 L/M)
Max. Discharge Pressure.....	3000 PSI	(210 BAR)
Max. RPM	3200 RPM	(3200 RPM)
Stroke	0.311"	(7.9 mm)

MODEL 4HP40G1

Volume.....	4.0 GPM	(15.0 L/M)
Max. Discharge Pressure.....	3000 PSI	(210 BAR)
Max. RPM	3200 RPM	(3200 RPM)
Stroke	0.354"	(9.0 mm)

COMMON PUMP SPECIFICATIONS

Max. Inlet Pressure.....	Flooded to 75 PSI	(Flooded to 5.25 BAR)
Bore.....	0.630"	(16 mm)
Shaft Diameter (Hollow)	1"	(25.4 mm)
Max. Fluid Temperature	140°F	(62°C)
Crankcase Capacity	22.65 oz.	(0.67 L)
Inlet Port (1)	1/2" NPT	(1/2" NPT)
By-Pass Port (1)	3/8" NPT	(3/8" NPT)
Discharge Ports (2)	3/8" NPT	(3/8" NPT)
Weight (Pump Only)	24.31 lbs.	(11.0 kg)
Dimensions (Pump Only) ...	10.83" x 7.08" x 6.38"	(275 x 180x 162 mm)

PUMP FEATURES

- Triplex plunger design provides a smooth fluid flow.
- Specially formulated Hi-Pressure V-Packing and concentrically ground ceramic plungers assure maximum seal life.
- Built-in flange mount for easy, direct mounting to most gas engines. Eliminates the need for pulleys, belts, gearboxes.
- Optional modular regulating unloader with built-in by-pass and stainless steel flow-thru screws to assure system pressure control and pump protection.
- Optional direct mounting chemical injector for cleaning flexibility.

DETERMINING THE PUMP R.P.M.	$\frac{\text{Rated G.P.M.}}{\text{Rated R.P.M.}}$	=	$\frac{\text{"Desired" G.P.M.}}{\text{"Desired" R.P.M.}}$
DETERMINING THE REQUIRED H.P.	$\frac{\text{GPM x PSI}}{1460}$	=	Electric Brake H.P. Required
DETERMINING MOTOR PULLEY SIZE	$\frac{\text{Motor Pulley O.D.}}{\text{Pump R.P.M.}}$	=	$\frac{\text{Pump Pulley O.D.}}{\text{Motor R.P.M.}}$

Note: Consult engine manufacturer when using gas or diesel engine.
 Refer to pump Service Manual for important Inlet Condition Check-List, Start-up Procedure, Tech Bulletins and Pump Maintenance information.

HORSEPOWER REQUIREMENTS

MODEL	FLOW		PRESSURE			RPM
	U.S. GPM	L/M	PSI 2000	PSI 2500	PSI 3000	
			BAR 140	BAR 175	BAR 210	
4HP35G1	3.5	13	4.8	6.0	7.2	3200
4HP40G1	4.0	15	5.5	6.9	8.3	3200

"Customer confidence is our greatest asset"

EXPLODED VIEW

May 1995

4HP PLUNGER PUMP MODELS

O.E.M. 4HP35G1, 4HP40G1

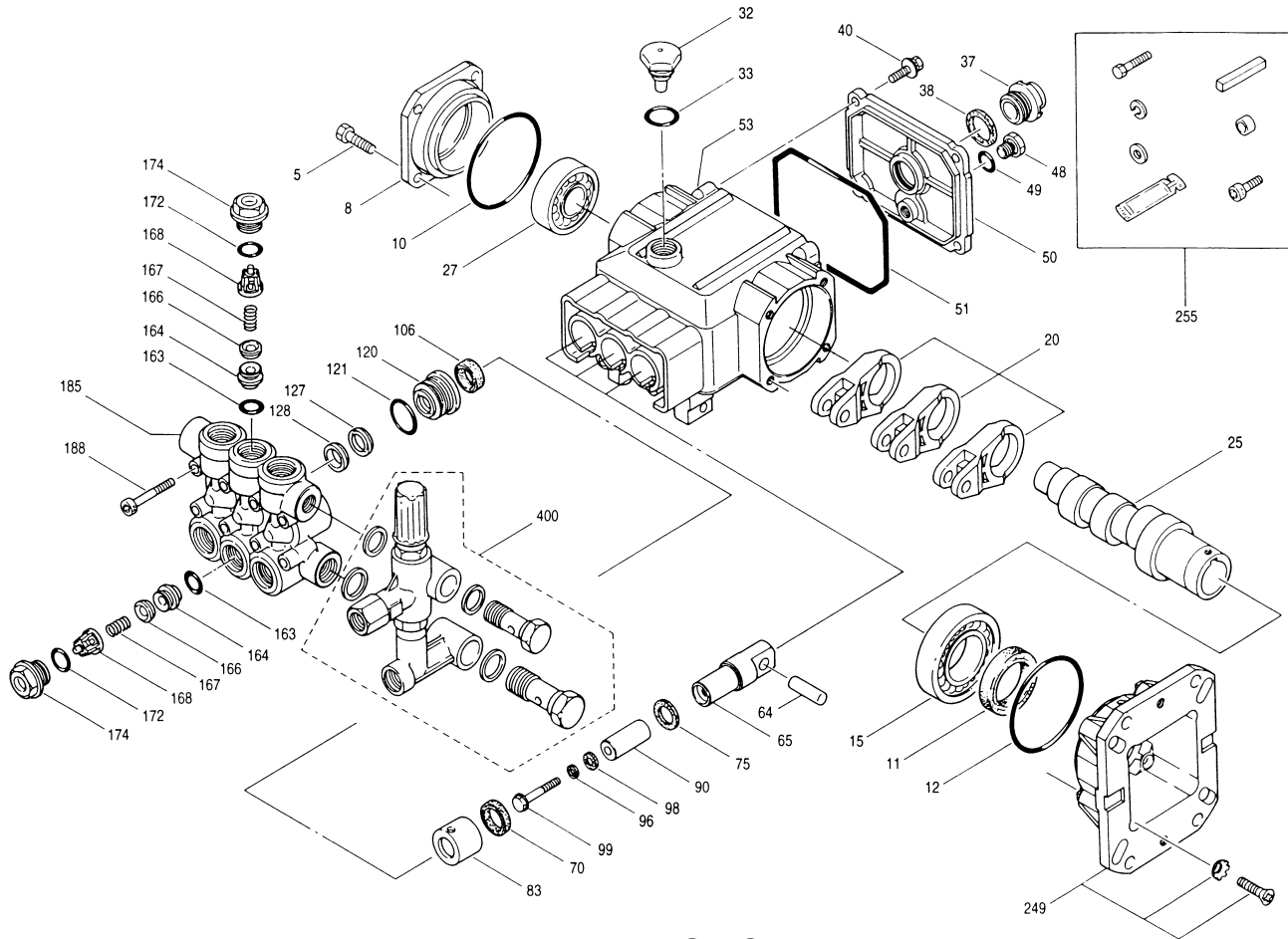

PARTS LIST

ITEM	PART NO.	DESCRIPTION	QTY	ITEM	PART NO.	DESCRIPTION	QTY
5	92521	Z Sems Hex Head Screw (M8x20)	4	98	45891	Z Gasket, Plunger Retainer	3
8	46461	A Bearing Case	1	●46730	B Sealing Gasket, Plunger Retainer	3	
10	14037	B O-Ring, Flange	1	99	104360	S Plunger Retainer	3
11	46419	B Oil Seal, Crankshaft	1	●46729	S Plunger Retainer	3	
12	14037	B O-Ring, Bearing Case	1	106	46435	B Lo-Pressure Seal	3
15	146421	Bearing - Inner	1	120	46471	BB Seal Case	3
20	46677	ZZ Connecting Rod	3	121	13980	B O-Ring, Seal Case	3
25	46551	Crankshaft - 4HP35G1	1	127	46617	BT V-Packing	3
	46460	Crankshaft - 4HP40G1	1	128	46618	P Male Adapter	3
27	14480	Bearing - Outer	1	163	17547	B O-Ring, Valve Seat	6
32	46798	Domed Oil Filler Cap	1	164	46658	S Valve Seat	6
33	14179	B O-Ring, Oil Filler Cap	1	166	46429	S Valve	6
37	43987	Oil Gauge, Bubble	1	167	43750	S Valve Spring	6
38	44428	B Gasket, Flat Flex.	1	168	45860	P Spring Retainer	6
40	92519	Z Sems Hex Head Screw (M6x16)	4	172	17615	B O-Ring, Valve Plug	6
48	25625	Drain Plug	1	174	46388	BB Valve Plug	6
49	23170	B O-Ring, Drain Plug	1	185	46526	BB Manifold Head	1
50	46379	A Crankcase Cover	1	188	87868	Z Hex Socket Head Screw (M8x107)	8
51	14048	B O-Ring, Crankcase Cover	1	249	46679	A Flange	1
53	46454	A Crankcase	1	46123	Z Toothed Lock Washer (M8)	4	
64	46404	S Pin, Plunger Rod	3	46403	Z Hex Flat Head Screw (M8x25)	4	
65	46525	BB Plunger Rod	3	255	30519	Bolt Mount Kit	1
	●46728	BB Plunger Rod	3	34100	Hex Bolt (3/8" x 1-3/8")	4	
70	29257	B Oil Seal, Crankcase	3	30921	Spring Washer (3/8")	4	
75	43900	S Barrier Slinger	3	30980	Washer (3/8")	4	
	●46732	S Barrier Slinger	3	6106	Antiseize Lubricant	1	
83	46408	P Seal Retainer	3	45217	Key (1/4"x1/4"x2-1/2") HD	1	
88	45697	S Keyhole Washer	3	34042	Spacer	4	
	●	Keyhole Washer	N/A	87788	Set Screw (M5x8)	1	
90	46524	CC Plunger	3	300	34062	Seal Kit (Incls: 97,106,121,127)	1
	●46727	CC Plunger	3	310	34060	BB Valve Kit (Incls: 163,164,166,167,168,172)	2
96	43235	T Back-up Ring, Plunger Retainer	3	400	7650	BB Modular Unloader Assembly	1
97	17399	B O-Ring, Plunger Retainer	3				
	●	O-Ring, Plunger Retainer	N/A				

● Items 88 and 97 are no longer used with ● items. These items must be replaced as a set. See Tech Bulletin 71 for additional information.

MATERIAL CODES (Not Part of Part Number): B=Buna N BB=Brass CC=Ceramic P=PVDF S=304SS SS=316SS T=Teflon V=Viton Z=Zinc Plated

7650 UNLOADER SPECIFICATIONS

	U.S. Measure	Metric Measure
GPM	2.0-5.0 GPM	(8-19 L/M)
PSI	700-3000 PSI	(50-210 BAR)
Inlet Port - Rear	3/8" NPT	(3/8" NPT)
Discharge Port - Front	3/8" NPT	(3/8" NPT)
By-Pass Port - Bottom	3/8" NPT	(3/8" NPT)
Weight	21.4 oz.	(0.65 L)
Dimensions	3.25" x 1.0" x 4.81"	(76 x 25 x 108 mm)

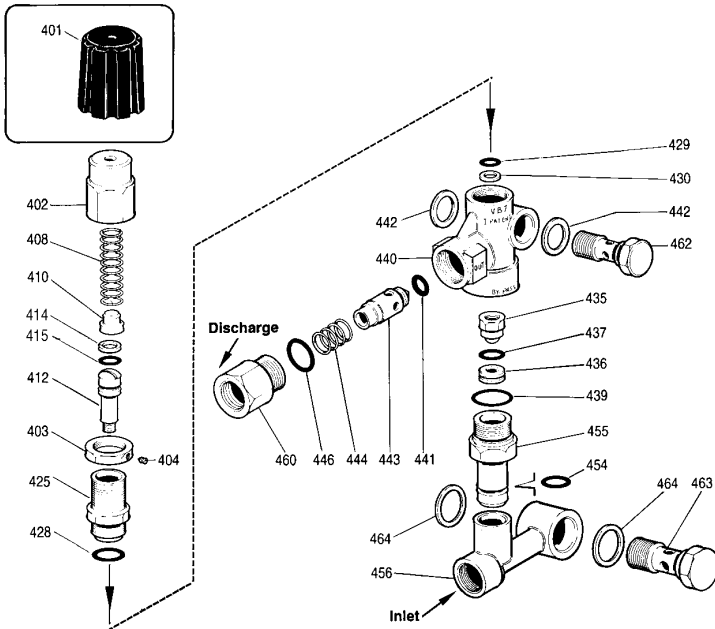

ITEM	PART NO.	DESCRIPTION	QTY.
401	32088	P Black Cap (Optional)	
402	33859	BB Hex Adjusting Cap	1
403	33857	Z Locking Nut (M18x1)	1
404	33061	Z Set Screw (M4x4)	1
408	32094	White Spring	1
410	32819	Z Spring Guide	1
412	33860	SS Valve Stem	1
414	—	Back-up Ring, Stem	1
415	—	O-Ring, Stem	1
425	33861	Piston Retainer	1
428	33043	B O-Ring, Retainer	1
429	—	B O-Ring, Stem	2
430	—	T Back-up Ring, Stem	1
435	33853	SS Valve and Ball Assembly (M6)	1
436	33862	SS Seat	1
437	32008	B O-Ring, Seat	1
439	33044	B O-Ring, By-Pass Fitting	2
440	—	BB Valve Body	1
441	32851	B O-Ring, Flow Balancer	1
442	33856	Seal Washer 3/8"	2
443	33852	BB Flow Balancer	1
444	33843	SS Spring, Flow Balancer	1
446	33043	B O-Ring, Discharge Fitting	1
454	—	V O-Ring, By-Pass Fitting	1
455	33863	BB By-Pass Fitting	1
456	33850	By-Pass Manifold 1/2" NPT	1
460	33855	Discharge Fitting 3/8" NPTF	1
462	33882	SS Screw, Flow-Thru 3/8" NPT	1
463	33884	SS Screw, Flow-Thru 1/2" NPT	1
464	33854	Seal Washer 1/2"	2
468	33098	O-Ring Kit (Incls: 414, 415, 428, 429, 430, 437, 439, 441, 446, 454)	1
—	7650.223	Unloader w/Injector (2.1 mm)	1
—	7650.224	Unloader w/Injector (2.3 mm)	1

OPERATION

A Regulating Unloader comes with each HP pump to provide system pressure regulation and pump protection.

A built-in by-pass system is provided. For frequent or prolonged by-pass, a Thermo Valve is recommended.

If unit is INFREQUENTLY USED OR PERIODICALLY STORED, seals may become dry. The system must be PURGED BEFORE OPERATION (system fluid must flow through the pump without discharge restriction) to assure full system pressure is reached.

CHEMICAL INJECTOR SPECIFICATIONS

Model	7223	7224
Flow	3.0-4.0 GPM	4.0-5.0 GPM
Nozzle Orifice	2.1 mm	2.3 mm
Hose Barb	1/4"	1/4"
Inlet Port	3/8" NPTM	3/8" NPTM
Discharge Port	3/8" NPTM	3/8" NPTM
Dimensions	2" x 1" x 3"	2" x 1" x 3"
Weight	6.3 oz.	6.3 oz.

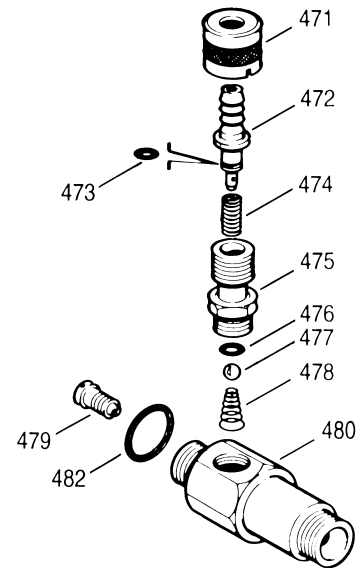

ITEM	PART NO.	DESCRIPTION	MODEL USED	QTY.
471	32940	BB Adjustment Collar	All Models	1
472	32941	BB Hose Barb	All Models	1
473	33503	B O-Ring	All models	1
474	33500	S Spring	All Models	1
475	33506	BB Ball Seat Retainer	All Models	1
476	33504	V O-Ring	All Models	1
477	33502	SS Ball	All Models	1
478	33501	SS Spring	All Models	1
479	32073	S Injector Orifice (2.1 mm) Std.	7223	1
	32074	S Injector Orifice (2.3 mm) Opt.	7224	1
480	—	BB Body-Unloader Mount	All Models	1
481	33481	BB Adjustable Barb Assembly (Incls: 471, 472, 473, 474, 475)	All Models	1
482	33480	BB Fixed Barb Assy - Optional (Incls: 475, 476, 477, 478)	All Models	1

CHEMICAL INJECTOR PERFORMANCE CHART

Desired Pump Flow	Orifice Size	Injector Model	Lo-Pressure Nozzle (Maximum injecting pressure less hose friction loss)	Max. Chem. Draw (0 PSI) (Downstream)	Hi-Press Nozzle "Deduction" (Pressure drop across Inj.)
3.5	2.1 mm	7223	300 PSI	50 oz/min	200 PSI
3.5	2.3 mm	7224	185 PSI	56 oz/min	175 PSI
4.0	2.1 mm	7223	375 PSI	54 oz/min	250 PSI
4.0	2.3 mm	7224	225 PSI	50 oz/min	225 PSI

Optimum performance of chemical injector occurs with a 35 ft. high pressure hose and a minimum 3/8" I.D. The type of hose, extended lengths, reduced I.D. and fittings may create back pressures in excess of the low pressure nozzle rating and prevent the injector from drawing chemical. See Hose Friction Loss Chart in High Pressure Guide. **Deduct hose friction loss from above low PSI Nozzle. Consult factory for assistance with other options.**

CAUTION:

Deduct the pressure drop shown in the performance chart from your desired system pressure to arrive at the maximum high pressure nozzle rating. This is essential to avoid over-pressurizing the pump.

Chemical draw occurs under low pressure. Select the Dual Nozzle (32149), Adjustable Nozzle (32151), or Vari-Nozzle (36666-72) to permit the adjustment from low to high pressure.

For optimum performance when using a chemical injector, use a **single wire braid hose** on the discharge line. Too flexible a hose will prevent the unloader from receiving the full pressure signal to activate the by-pass mode.

For correct nozzle selection, **read system pressure at the pump. DO NOT READ SYSTEM PRESSURE AT THE HIGH PRESSURE GUN.** Incorrect pressure reading may result in: pump operation at excessive pressures, inconsistent chemical draw or possible damage to the pump or unloader.

DIMENSIONAL

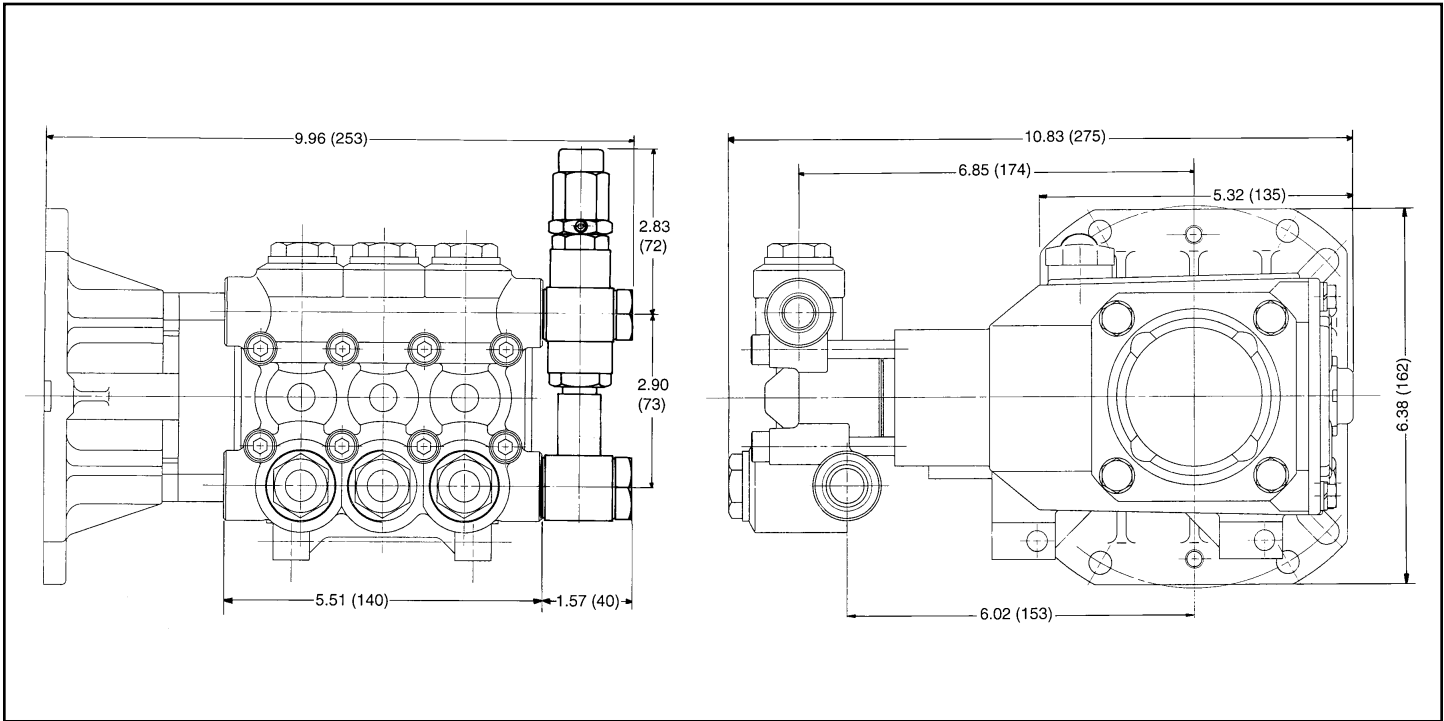

May 1995 9346

World Headquarters

CAT PUMPS

1681 - 94th Lane N.E. Minneapolis, MN 55449-4324

Phone (763) 780-5440 — FAX (763) 780-2958

e-mail: techsupport@catpumps.com

www.catpumps.com

International Inquiries

FAX (763) 785-4329

e-mail: intlsales@catpumps.com



The Pumps with Nine Lives

CAT PUMPS (U.K.) LTD.

1 Fleet Business Park, Sandy Lane, Church Crookham, Fleet

Hampshire GU52 8BF, England

Phone Fleet 44 1252-622031 — Fax 44 1252-626655

e-mail: sales@catpumps.co.uk

N.V. CAT PUMPS INTERNATIONAL S.A.

Heiveldekens 6A, 2550 Kontich, Belgium

Phone 32-3-450.71.50 — Fax 32-3-450.71.51

e-mail: cpi@catpumps.be www.catpumps.be

CAT PUMPS DEUTSCHLAND GmbH

Buchwiese 2, D-65510 Idstein, Germany

Phone 49 6126-9303 0 — Fax 49 6126-9303 33

e-mail: catpumps@t-online.de www.catpumps.de