

Model 5CP3120 Shown  
(Rails and shaft protector sold separately)

## FEATURES

- Industrial triplex design offers reliability and versatility.
- Optional single shaft with side gauge.
- Ultra-compact direct-drive mount to motor using bell housing and flexible coupling or gas engine with gearbox.
- Optional belt-drive for precision flow setting.
- Optional EPDM and FPM elastomers for compatibility with many liquids.
- Press-in seal cases and interchangeable valve assemblies for easy servicing.

## COMMON SPECIFICATIONS

Inlet Pressure Range.....	-2.5 to 60 psi	(- 2 to 4 bar)
Bore .....	0.630"	(16mm)
Crankcase Capacity.....	17 oz.	(0.51 l)
Max. Liquid Temperature .....	160°F	(71°C)

Above 130°F call CAT PUMPS for inlet conditions and elastomer recommendations.

Inlet Ports (2) .....	1/2" NPTF	(1/2" NPTF)
Discharge Ports (2).....	3/8" NPTF	(3/8" NPTF)
Shaft Diameter .....	0.787"	(20 mm)

### ⚠ CAUTIONS AND WARNINGS

All High Pressure Systems require a primary pressure regulating device (i.e. regulator, unloader) and a secondary pressure relief device (i.e. pop-off valve, relief valve). Failure to install such relief devices could result in personal injury or damage to pump or property. CAT PUMPS does not assume any liability or responsibility for the operation of a customer's high pressure system.

Read all CAUTIONS and WARNINGS before commencing service or operation of any high pressure system. The CAUTIONS and WARNINGS are included in each service manual and with each Accessory Data sheet. CAUTIONS and WARNINGS can also be viewed online at [www.catpumps.com/cautions-warnings](http://www.catpumps.com/cautions-warnings) or can be requested directly from CAT PUMPS.

### WARRANTY

View the Limited Warranty on-line at [www.catpumps.com/warranty](http://www.catpumps.com/warranty).

## 5CP Plunger Pump

**Standard Models**

**5CP3120**  
**5CP3120CSS**

**Gearbox Model**

**5CP3120CSSG1**

## SPECIFICATIONS

U.S.      Metric

### MODEL 5CP3120

Flow.....	4.5 gpm	(17 lpm)
Pressure Range.....	100-3500 psi	(7-245 bar)
Pump RPM .....	1645 rpm	(1645 rpm)
Stroke.....	0.709"	(18 mm)
Weight.....	19.9 lbs.	(9 kg)
Dimensions.....	10.4 x 10.0 x 5.8" (264 x 254 x 147 mm)	

### MODEL 5CP3120CSS

Flow.....	4.8 gpm	(18 lpm)
Pressure Range.....	100-3000 psi	(7-210 bar)
Pump RPM .....	1750 rpm	(1750 rpm)
Stroke.....	0.709"	(18 mm)
Weight.....	19.9 lbs.	(9 kg)
Dimensions.....	10.4 x 8.6 x 5.8" (214 x 218 x 147 mm)	

### MODEL 5CP3120CSSG1

Flow.....	4.5 gpm	(17 lpm)
Pressure Range.....	100-3500 psi	(7-245 bar)
Pump RPM .....	1645 rpm	(1645 rpm)
Engine RPM .....	3353 rpm	(3353 rpm)
Stroke.....	0.709"	(18 mm)
Weight.....	26.5 lbs.	(12 kg)
Dimensions.....	11.0 x 12.7 x 6.4" (279 x 324 x 163 mm)	

## ELECTRIC HORSEPOWER REQUIREMENTS

MODEL	FLOW		PRESSURE						MOTOR PULLEY SIZE	
			psi 1200	psi 1500	psi 2000	psi 2500	psi 3000	psi 3500	Using 1725 rpm Motor & 8" Std. Pump Pulley	
	u.s. gpm	lpm	bar 85	bar 105	bar 140	bar 175	bar 210	bar 245	rpm	Pulley O.D.
<b>3120</b>	4.5	17	3.7	4.6	6.2	7.7	9.3	10.8	1645	7.5
<b>3120CSS</b>	4.8	18	3.9	4.9	6.6	8.2	9.9	NA	1750	Direct-Drive
<b>3120CSSG1</b>	4.5	17	Consult Eng. Mfg.						3353	Gearbox

<b>DETERMINING THE PUMP RPM</b>	$\frac{\text{Rated gpm}}{\text{Rated rpm}}$	=	$\frac{\text{"Desired" gpm}}{\text{"Desired" rpm}}$
<b>DETERMINING THE REQUIRED H.P.</b>	$\frac{\text{gpm} \times \text{psi}}{1460}$	=	Electric Brake H. P. Required
<b>DETERMINING MOTOR PULLEY SIZE</b>	$\frac{\text{Motor Pulley O.D.}}{\text{Pump rpm}}$	=	$\frac{\text{Pump Pulley O.D.}}{\text{Motor rpm}}$

See complete Drive Packages [Incls: Pulleys, Belts, Hubs, Key] Tech Bulletin 003.  
Refer to pump **Service Manual** for repair procedure and additional technical information.

# PARTS LIST

ITEM	PART NUMBER		DESCRIPTION		QTY	
	<b>5CP3120CSS</b>					
	<b>5CP3120</b>	<b>MATL</b>	<b>5CP3120CSSG1</b>	<b>MATL</b>		
2	30057	STL	30057	STL	Key (M6x6x25)	1
5	96031	STZP	96031	STZP	Screw, HHC, Sems (M8x16)	8
	126542	STCPR	126542	STCPR	Screw, HHC, Sems (M8x16)	8
8	46910	AL	46910	AL	Cover, Bearing	2 - 1 - 0
10	14028	NBR	14028	NBR	O-Ring, Bearing Cover - 70D	2 - 2 - 1
11	43222	NBR	43222	NBR	Seal, Oil, Crankshaft - 70D	2 - 1 - 0
15	14480	STL	14480	STL	Bearing, Ball	2 - 2 - 2
20	48742	TNM	48742	TNM	Rod, Connecting Assy [10/01]	3
25	<b>46928</b>	<b>FCM</b>	—	—	Crankshaft, Dual End, M18 - 5CP3120	1
	—	—	<b>48233</b>	<b>FCM</b>	Crankshaft, Single End, M18 - 5CP3120CSS, 5CP3120CSSG1	1
30	—	—	<b>49776</b>	<b>AL</b>	Cover, Bearing - 5CP3120CSS, 5CP3120CSSG1 [After 12/10]	1
	—	—	<b>48224</b>	<b>AL</b>	Cover, Bearing Blind - 5CP3120G1 [Prior to 12/10]	1
32	46798	—	46798	—	Cap, Oil Filler, Domed	1
33	14179	NBR	14179	NBR	O-Ring, Oil Filler Cap - 70D	1
37	92241	—	92241	—	Gauge, Oil, Bubble w/Gasket - 80D	1 - 2
38	44428	NBR	44428	NBR	Gasket, Flat, Oil Gauge - 80D	1 - 2
40	92519	STZP	92519	STZP	Screw, HHC, Sems (M6x16)	4
	125824	STCPR	125824	STCPR	Screw, HHC, Sems (M6x16)	4
48	25625	STCP	25625	STCP	Plug, Drain (1/4"x19BSP)	1
49	23170	NBR	23170	NBR	O-Ring, Drain Plug - 70D	1
50	46940	AL	46940	AL	Cover, Rear	1
51	14044	NBR	14044	NBR	O-Ring, Rear Cover	1
53	48617	AL	48617	AL	Crankcase	1
64	46746	CM	46746	CM	Pin, Crosshead	3
65	48458	BBNP	48458	BBNP	Rod, Plunger	3
70	46838	NBR	46838	NBR	Seal, Oil, Crankcase - 70D	3
75	43900	S	43900	S	Slinger, Barrier	3
88	45697	S	45697	S	Washer, Keyhole (M18x10)	3
90	46884	CC	46884	CC	Plunger (M16x50)	3
98	46730	NBR	46730	NBR	Washer, Seal - 90D	3
	48394	FPM	48394	FPM	Washer, Seal - 90D	3
	◆ 48432	EPDM	◆ 48432	EPDM	Washer, Seal	3
99	† 48201	SS	† 48201	SS	Retainer, Plunger w/Stud (M6)	3
100	46749	PVDF	46749	PVDF	Retainer, Seal	3
106	43316	NBR	43316	NBR	Seal, LPS w/S-Spg	3
	106660	FPM	106660	FPM	Seal, LPS w/S-Spg	3
	◆ 49134	EPDM	◆ 49134	EPDM	Seal, LPS w/S-Spg	3
	76316	ST2	76316	ST2	Seal, LPS w/S-Spg	3
120	46888	BB	46888	BB	Case, Seal (Press-in-style)	3
121	13978	NBR	13978	NBR	O-Ring, Seal Case - 70D	3
	14329	FPM	14329	FPM	O-Ring, Seal Case	3
	◆ 48904	EPDM	◆ 48904	EPDM	O-Ring, Seal Case	3
127	43319	SNG	43319	SNG	V-Packing	6
	46287	HT*	46287	HT*	V-Packing	6
128	46618	NY	46618	NY	Adapter, Male	3
139	22179	BBCP	22179	BBCP	Plug, Inlet (1/2"NPTM)	1
163	17547	NBR	17547	NBR	O-Ring, Seat - 85D	6
	11685	FPM	11685	FPM	O-Ring, Seat - 85D	6
	◆ 46648	EPDM	◆ 46648	EPDM	O-Ring, Seat - 70D	6
164	45790	S	45790	S	Seat	6
166	46429	S	46429	S	Valve	6
167	43750	S	43750	S	Spring	6
168	† 44565	PVDF	† 44565	PVDF	Retainer, Spring	6
172	17549	NBR	17549	NBR	O-Ring, Valve Plug - 70D	6
	26996	FPM	26996	FPM	O-Ring, Valve Plug - 70D	6
	◆ 49133	EPDM	◆ 49133	EPDM	O-Ring, Valve Plug	6
173	48365	D	48365	D	Back-up-Ring, Valve Plug	6
174	45900	BB	45900	BB	Plug, Valve	6
185	46886	FBB	46886	FBB	Manifold, Head	1
188	126513	STCPR	126513	STCPR	Screw, HSH (M8x70)	8
196	22187	BBCP	22187	BBCP	Plug, Discharge (3/8"NPTM)	1
250	<b>118672</b>	<b>STCP</b>	—	—	Protector, Shaft	1
255	30243	STZP	30243	STZP	Mount, Direct	1
260	30611	STZPR	30611	STZPR	Mount, Rail, Assy	1
	30637	STZP	30637	STZP	Mount, Angle Assy-Retro Fit (See Tech Bulletin 078)	1
265	<b>30659</b>	—	—	—	Kit, Complete Mounting (Incls: 30611, 30633, 118672) (Belt Drive Only)	1
275	30944	STL	30944	STL	Assembly, Hub & Key (Incls: 30945, 30057)	1
283	76334	—	76334	—	Kit, Oil Indicator (3/8" x 24") (See Individual Data Sheet)	1
	34334	—	34334	—	Kit, Oil Drain (3/8" x 24") (See Individual Data Sheet)	1

# EXPLODED VIEW

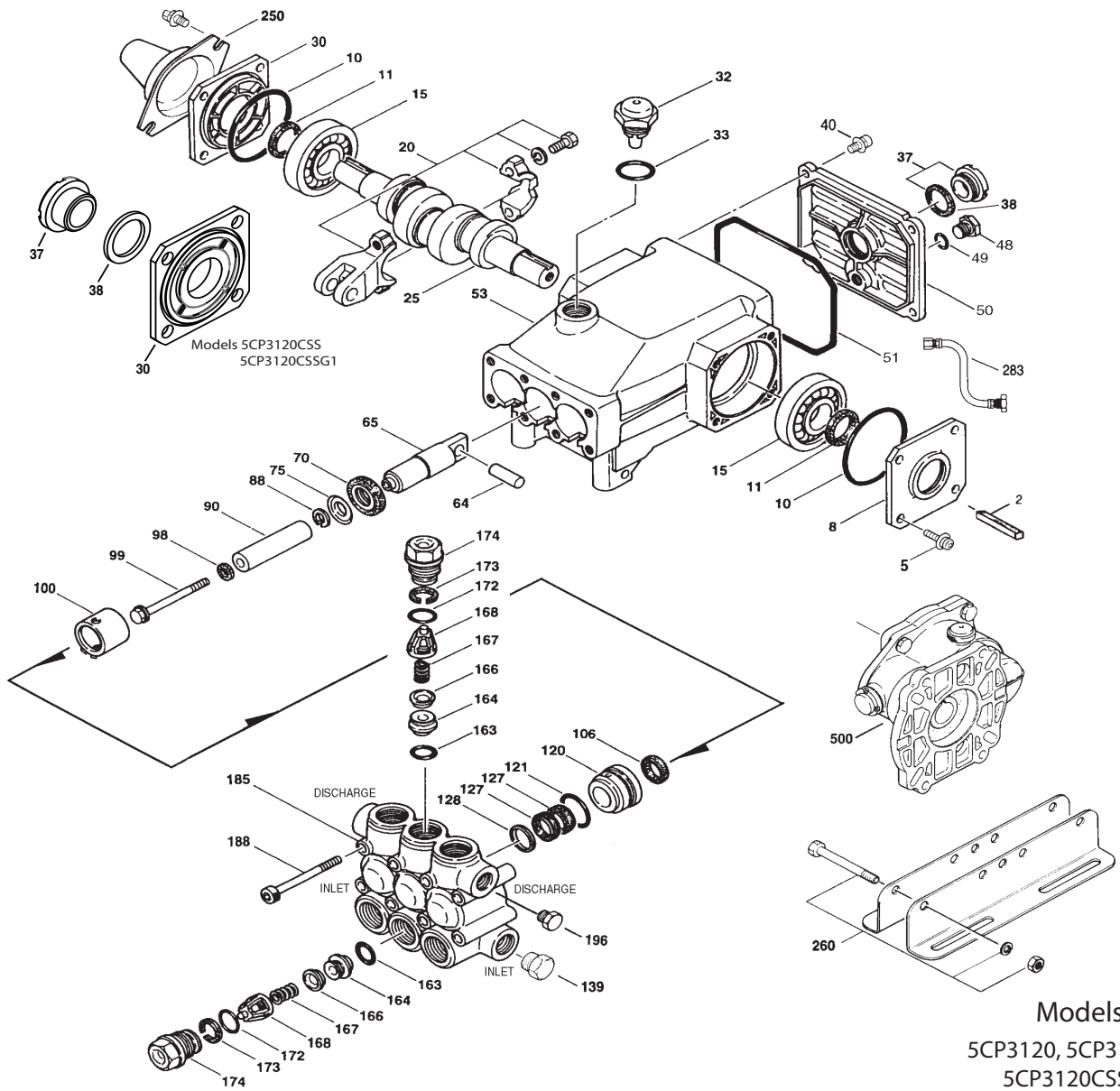

Models  
5CP3120, 5CP3120CSS  
5CP3120CSSG1  
July 2011

5CP3120		MATL	5CP3120CSS	MATL	
299	814843	FBB	814843	FBB	Head, Complete
300	33629	NBR	33629	NBR	Kit, Seal (Incls: 98,106,121,127,128)
	31340	FPM*	31340	FPM*	Kit, Seal (Incls: 98,106,121,127,128)
	◆ 31730	EPDM*	◆ 31730	EPDM*	Kit, Seal (Incls: 98,106,121,127,128)
	31665	HT	31665	HT	Kit, Seal (Incls: 98,106,121,127,128)
	76556	STHT	76556	STHT	Kit, Seal (Incls: 98,106,120,121,127,128)
310	33060	NBR	33060	NBR	Kit, Valve Preassembled (Incls: 163,164,166-168,172,173)
	31345	FPM	31345	FPM	Kit, Valve Preassembled (Incls: 163,164,166-168,172,173)
	◆ 31735	EPDM	◆ 31735	EPDM	Kit, Valve Preassembled (Incls: 163,164,166-168,172,173)
350	30696	STZP	30696	STZP	Pliers, Reverse
400	7850	BB	7850	BB	Modular Unloader (See Individual Data Sheet)
500	—	—	<b>8076</b>	—	Gearbox (See Individual Data Sheet)
—	6107	—	6107	—	Oil, Bottle (21 oz.) ISO 68 Hydraulic

(Fill to specified crankcase capacity prior to start-up)

**Bold print part numbers are unique to a particular pump model. Italics are optional items. [ ]** Date of latest production change.

◆ Silicone oil/grease required. † Production parts are different than repair parts. R Components comply with RoHS Directive.

\*Review individual parts in each kit for material code identification.

View Tech Bulletins 002, 003, 024, 036, 043, 053, 060, 061, 064, 073, 074, 077, 078 and 083 for additional information.

MATERIAL CODES (Not Part of Part Number): AL=Aluminum BB=Brass BBCP=Brass/Chrome Plated BBNP=Brass/Nickel Plated CC=Ceramic  
CM=Chrome-moly D=Acetal EPDM=Ethylene Propylene Diene Monomer FBB=Forged Brass FCM=Forged Chrome-moly FPM=Fluorocarbon  
HT=Hi-Temp (EPDM Alternative) NBR=Medium Nitrile (Buna-N) NY=Nylon PVDF=Polyvinylidene Fluoride S=304SS SS=316SS SNG=Special Blend (Buna)  
ST2=Special Blend PTFE Grey STHT=Special PTFE High Temp STL=Steel STCP=Steel/Chrome Plated STZP=Steel/Zinc Plated TNM=Special High Strength

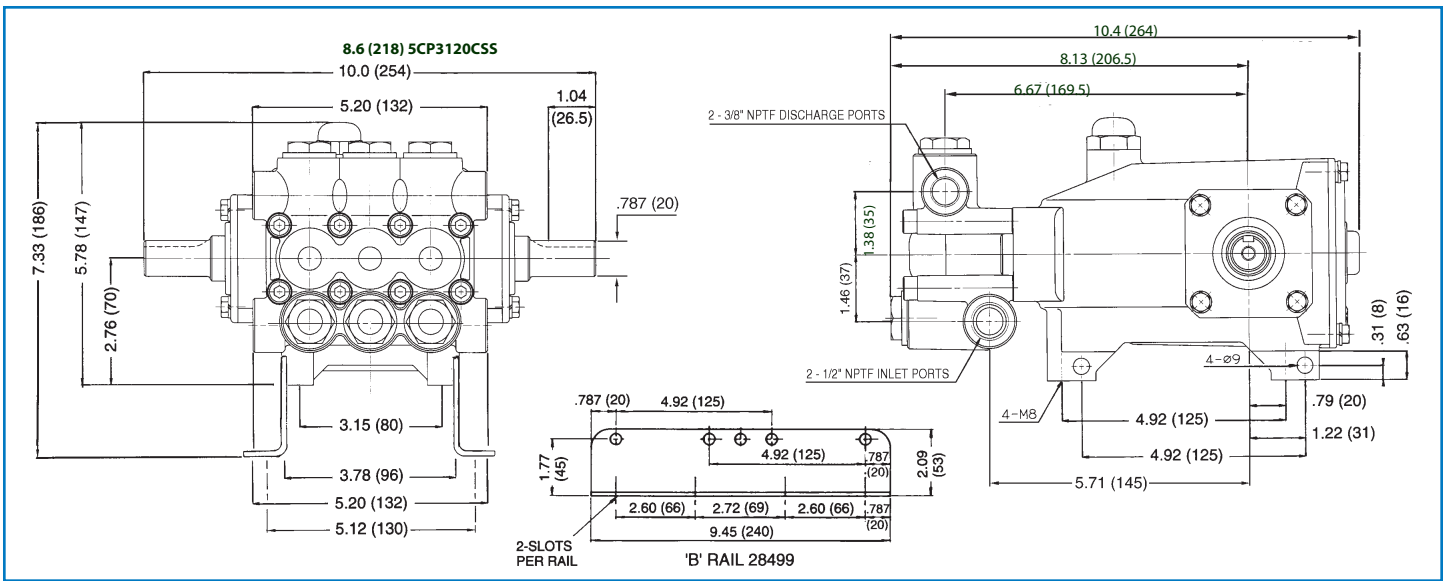

Models 5CP3120, 5CP3120CSS

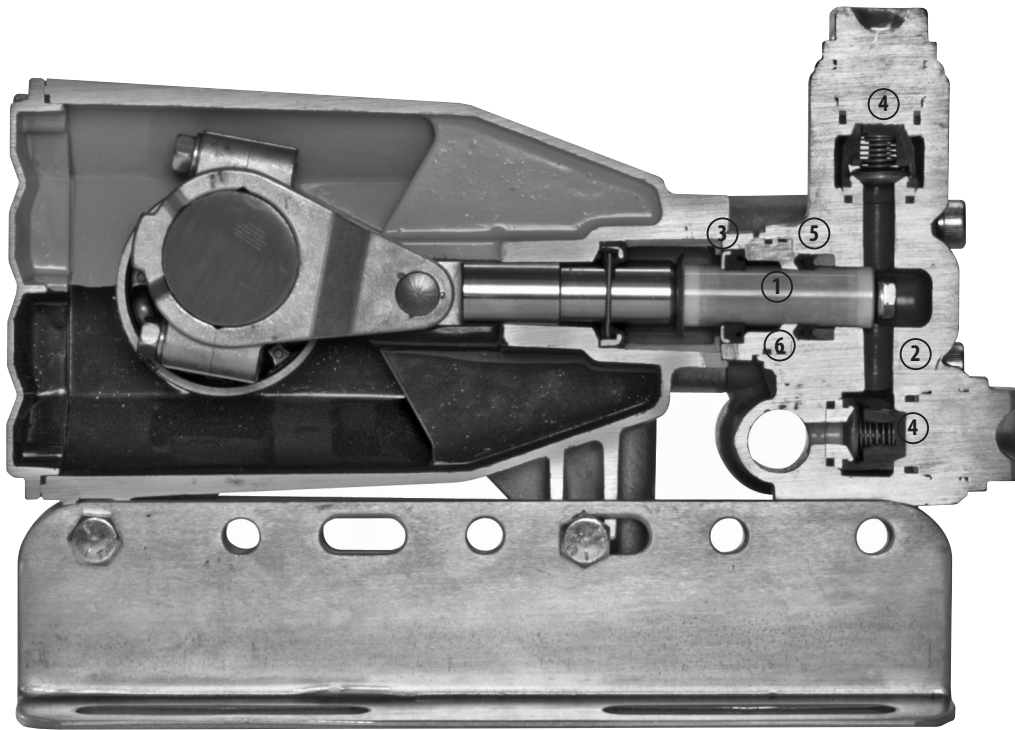

Model 5CP3120 Shown

- 1 Special concentric, high density, polished, solid ceramic **plungers** provide a true wear surface and extended seal life.
- 2 **Manifolds** are a high tensile strength forged brass for long term, continuous duty.
- 3 100% wet **seal** design adds to service life by allowing pumped liquids to cool and lubricate on both sides of the seals.
- 4 Stainless **steel valves, seats and springs** provide corrosion-resistance, ultimate seating and extended life.
- 5 Specially formulated, CAT PUMP exclusive **V-Packings** offer unmatched performance and seal life.
- 6 Press-in style **seal case** offers alignment and support for seals and “no tools” servicing.



**CAT PUMPS**  
 1681 - 94TH LANE N.E. MINNEAPOLIS, MN 55449-4324  
 PHONE (763) 780-5440 — FAX (763) 780-2958  
 e-mail: techsupport@catpumps.com  
 www.catpumps.com