

5CP Stainless Steel Plunger Pump

Models **5CP6121**
 5CP6141
 5CP6151

Superior Design

- Triplex plunger design gives smoother fluid flow.
- Hi-Pressure Seals are completely lubricated and cooled by the fluid being pumped.
- Inlet and discharge valve assemblies interchange for easier maintenance.
- Lubricated Lo-Pressure Seal provides double protection against external leakage.
- Oil bath crankcase assures optimum lubrication.
- Close tolerance concentricity of the ceramic plunger offers perfect alignment and maximizes seal life.

Quality Materials

- All 316 stainless steel valves are heat treated and seats are roller burnished for a positive seal and extended valve life.
- 316 stainless steel manifold is strong and corrosion resistant.
- Special concentric, high density, polished, graphite impregnated, solid ceramic plungers are abrasion resistant and result in extended seal life.
- Specially formulated, CAT PUMP exclusive, Hi-Pressure Seals offer unmatched performance and seal life.
- Die cast aluminum crankcase provides high strength, minimum weight and precision tolerance control.
- Chrome-moly crankshaft gives unmatched strength and surface hardness.
- Oversized crankshaft bearings with greater capacity mean longer bearing life.

Easy Maintenance

- Wet-end is easily serviced without entering crankcase, requiring less time and effort.
- Preset packings mean no packing gland adjustment is necessary, reducing maintenance costs.

DETERMINING THE PUMP R.P.M. $\frac{\text{Rated G.P.M.}}{\text{Rated R.P.M.}} = \frac{\text{"Desired" G.P.M.}}{\text{"Desired" R.P.M.}}$

DETERMINING THE REQUIRED H.P. $\frac{\text{GPM} \times \text{PSI}}{1460} = \text{Electric Brake H. P. Required}$

DETERMINING MOTOR PULLEY SIZE $\frac{\text{Motor Pulley O.D.}}{\text{Pump R.P.M.}} = \frac{\text{Pump Pulley O.D.}}{\text{Motor R.P.M.}}$

Note: Consult engine manufacturer when using gas or diesel engine. Refer to pump Service Manual for important Inlet Condition Check-List, Start-up Procedure, Tech Bulletins and Pump Maintenance information.

SPECIFICATIONS

	U.S. Measure	Metric Measure
MODEL 5CP6121		
Volume	6.0 GPM	(23 L/M)
Discharge Pressure	100 to 1600 PSI	(7 to 112 BAR)
Maximum Inlet Pressure	-5 to 60 PSI	(-0.35 to 4 BAR)
RPM	1450 RPM	(1450 RPM)
Stroke.....	0.709"	(18 mm)

MODEL 5CP6141 Direct Drive		
Volume	4.0 GPM	(15 L/M)
Discharge Pressure	100 to 1600 PSI	(7 to 112 BAR)
Maximum Inlet Pressure.....	Flooded to 60 PSI	(Flooded to 4 BAR)
RPM	1725 RPM	(1725RPM)
Stroke.....	0.394"	(10 mm)

MODEL 5CP6151 Direct Drive		
Volume	5.0 GPM	(19 L/M)
Discharge Pressure	100 to 1600 PSI	(7 to 112 BAR)
Maximum Inlet Pressure.....	Flooded to 60 PSI	(Flooded to 4 BAR)
RPM	1725 RPM	(1725RPM)
Stroke.....	0.472"	(12 mm)

COMMON SPECIFICATIONS

Bore.....	0.787"	(20 mm)
Crankcase Capacity	17 oz.	(0.53 L)
Max Fluid Temperature.....	160°F	(71°C)
Inlet Ports (2)	1/2" NPTF	(1/2" NPTF)
Discharge Ports (2).....	3/8" NPTF	(3/8" NPTF)
Shaft Diameter	0.787"	(20 mm)
Weight.....	20 lbs.	(8 kg)
Dimensions	10.82" x 10.0" x 5.78"	(275 x 254 x 147 mm)

HORSEPOWER REQUIREMENTS

MODEL	FLOW		PRESSURE			RPM
			PSI 1000	PSI 1200	PSI 1600	
	U.S. GPM	L/M	BAR 70	BAR 85	BAR 112	
5CP6121	6.0	23	4.1	5.0	6.6	1450
	5.0	19	3.4	4.1	5.5	1208
	4.0	15	2.8	3.3	4.4	966
5CP6141	4.0	15	2.8	3.3	4.4	1725
5CP6151	5.0	19	3.4	4.1	5.5	1725

See complete Drive Packages [Incls: Pulleys, Belts, Hubs, Key]Tech Bulletin 03.

"Customer confidence is our greatest asset"

PARTS LIST

ITEM	PART NUMBER				DESCRIPTION	QTY	
	5CP6121	MATL	5CP6141	MATL	5CP6151	MATL	
● 2	30057	STL	30057	STL	30057	STL	Key (M6x6) 1 ●
5	119049	SS	119049	SS	119049	SS	Screw, Sems HHC (M8x16) 8
8	46910	AL	46910	AL	46910	AL	Cover, Bearing 2
10	14028	NBR	14028	NBR	14028	NBR	O-Ring, Cover, Bearing 1/2
11	43222	NBR	43222	NBR	43222	NBR	Seal, Oil, Crankshaft 2
15	14480	STL	14480	STL	14480	STL	Bearing 2
20	46743	ZZ	46743	ZZ	46743	ZZ	Rod Assy, Connecting 3
25	46928	FCM	—	—	—	—	Crankshaft, Dual End 1
30	48224	AL	48203	FCM	46982	FCM	Crankshaft, Single End 1
32	46798	—	46798	AL	48224	AL	Cover, Blind Bearing 1
33	14179	NBR	14179	NBR	46798	Cap, Oil Filler 1	
37	43987	—	43987	NBR	14179	NBR	O-Ring, Oil Filler Cap 1
38	44428	NBR	43987	—	43987	Gauge, Oil, Bubble 1	
40	92538	SS	44428	NBR	44428	NBR	Gasket, Flat, Oil Gauge 1
48	25625	STCP	92538	SS	92538	SS	Screw, Sems HHC (M6x16) 4
49	23170	NBR	25625	STCP	25625	STCP	Plug, Drain (1/4X11) 1
50	46940	AL	23170	NBR	23170	NBR	O-Ring, Drain Plug 1
51	14044	NBR	46940	AL	46940	AL	Cover, Crankcase 1
53	48310	AL	14044	NBR	14044	NBR	O-Ring, Cover, Crankcase 1
64	46746	S	48310	AL	48310	AL	Crankcase 1
65	46747	BBCP	46746	S	46746	S	Pin, Plunger Rod 3
70	46838	NBR	46747	BBCP	46747	BBCP	Rod, Plunger 3
71	48208	S	46838	NBR	46838	NBR	Seal, Oil, Crankcase 3
75	43328	S	48208	S	48208	S	Washer, Oil Seal 3
88	45697	S	43328	S	43328	S	Slinger, Barrier 3
90	46841	CC	45697	S	45697	S	Washer, Keyhole (M18) 3
98	46730	NBR	46841	CC	46841	CC	Plunger 3
	48394	FPM	46730	NBR	46730	NBR	Washer, Seal 3
	48432	EPDM	48394	FPM	48394	FPM	Washer, Seal 3
99	48201	SS	48432	EPDM	48432	EPDM	Washer, Seal 3
100	46749	PVDF	48201	SS	48201	SS	Retainer, Plunger (M6x30) 3
106	44127	NBR	46749	PVDF	46749	PVDF	Retainer, Seal 3
	45153	FPM	44127	NBR	44127	NBR	LPS w/S-Spg 3
	48429	EPDM	45153	FPM	45153	FPM	LPS w/S-Spg 3
	48210	SS	48429	EPDM	48429	EPDM	LPS w/S-Spg 3
110	119034	S	48210	SS	48210	SS	Manifold, Inlet 1 ●
125	44649	NBR	119034	S	119034	S	Screw, HSH (M8x35) 4
	44936	FPM	44649	NBR	44649	NBR	HPS w/SS 3
	46667	EPDM	44936	FPM	44936	FPM	HPS w/SS 3
	46667	HT	46667	EPDM	46667	EPDM	HPS w/SS 3
143	17615	NBR	46667	HT	46667	HT	HPS w/SS 3
	15855	FPM	17615	NBR	17615	NBR	O-Ring, I.V. Adapter, Rear 3
	48431	EPDM	15855	FPM	15855	FPM	O-Ring, I.V. Adapter, Rear 3
150	48212	SS	48431	EPDM	48431	EPDM	O-Ring, I.V. Adapter, Rear 3
154	43781	NBR	48212	SS	48212	SS	Adapter, Inlet 3
	11337	FPM	43781	NBR	43781	NBR	O-Ring, I.V. Adapter, Front 3
	48430	EPDM	11337	FPM	11337	FPM	O-Ring, I.V. Adapter, Front 3
155	43781	NBR	48430	EPDM	48430	EPDM	O-Ring, I.V. Adapter, Front 3
	11337	FPM	43781	NBR	43781	NBR	O-Ring, D.V. Spacer 3
	48430	EPDM	11337	FPM	11337	FPM	O-Ring, D.V. Spacer 3
157	48211	SS	48430	EPDM	48430	EPDM	O-Ring, D.V. Spacer 3
159	43781	NBR	48211	SS	48211	SS	Spacer, Discharge Valve 3
	11337	FPM	43781	NBR	43781	NBR	O-Ring, D.V. Spacer 3
	48430	EPDM	11337	FPM	11337	FPM	O-Ring, D.V. Spacer 3
163	43793	NBR	48430	EPDM	48430	EPDM	O-Ring, D.V. Spacer 3
	43791	FPM	43793	NBR	43793	NBR	O-Ring, Seat - 90 3
	48490	EPDM	43791	FPM	43791	FPM	O-Ring, Seat - 90 3
164	48216	SS	48490	EPDM	48490	EPDM	O-Ring, Seat - 70 3
165	43793	NBR	48216	SS	48216	SS	Seat 6
	43791	FPM	43793	NBR	43793	NBR	O-Ring, Seat - 90 6
	48490	EPDM	43791	FPM	43791	FPM	O-Ring, Seat - 90 6
166	44038	SS	48490	EPDM	48490	EPDM	O-Ring, Seat - 70 6
167	44039	SS	44038	SS	44038	SS	Valve 6
168	44564	PVDF	44039	SS	44039	SS	Spring 6
● 185	48214	SS	44564	PVDF	44564	PVDF	Retainer, Spring 6
186	19085	S	48214	SS	48214	SS	Manifold, Discharge 1 ●
188	89575	S	19085	S	19085	S	Lockwasher, Split (M12) 4
250	118672	STCP	89575	S	89575	S	Screw, HSH (M12x60) 4
260	30611	STZP	118672	STCP	118672	STCP	Protector, Shaft 1
269	—	—	30611	STZP	30611	STZP	Rail Assy, Angle (Incls: 27808, 30902, 30930, 30908, 30911) 1
270	—	—	—	—	—	—	Pulley [See complete Drive Packages, Tech Bulletin 03] 1
278	30944	—	—	—	—	—	Hub [See complete Drive Packages, Tech Bulletin 03] 1
279	—	—	34418	—	34419	—	Flex Coupling 1
280	—	—	34424	—	34424	—	Bell Housing 1
● 283	34334	—	—	—	—	—	BD Direct Drive Motor [See Individual Data Sheet] 1
290	6108	—	34334	—	34334	—	Kit, Oil Drain 1 ●
● 299	—	—	6108	—	6108	—	Gasket, Liquid (1.5 oz.) 1
300	34353	NBR	—	—	—	—	Head, Complete 1 ●
	34351	FPM	34353	NBR	34353	NBR	Kit, Seal (Incls: 98, 106, 125, 143, 154, 155, 159) 1
	34352	EPDM	34351	FPM	34351	FPM	Kit, Seal (Incls: 98, 106, 125, 143, 154, 155, 159) 1
310	33972	NBR	34352	EPDM	34352	EPDM	Kit, Seal (Incls: 98, 106, 125, 143, 154, 155, 159) 1
	34362	FPM	33972	NBR	33972	NBR	Kit, Valve (Incls: 143, 154, 163, 164, 165, 166, 167, 168) 1
	34363	EPDM	34362	FPM	34362	NBR	Kit, Valve (Incls: 143, 154, 163, 164, 165, 166, 167, 168) 1
	—	—	34363	EPDM	34363	EPDM	Kit, Valve (Incls: 143, 154, 163, 164, 165, 166, 167, 168) 1

● Industrial discount. **Bold print part numbers are unique to a particular pump model.** *Italics are optional items.* ◆ Silicone oil/grease required.

See Tech Bulletins 03, 24, 36, 43, 53, 56, 74, and 77 for additional information.

MATERIAL CODES (Not Part of Part Number): AL=Aluminum BBCP=Brass/Chrome Plated CC=Ceramic EPDM=Ethylene Propylene Diene Monomer
 FCM=Forged Chrome-Moly FPM=Fluorocarbon (Viton®) HT=Hi-Temp (EPDM Alternative) NBR=Medium Nitrile (Buna-N) PVDF=Fluoroplastic (High Strength)
 S=304SS SS=316SS STCP=Steel/Chrome Plated STZP=Steel/Zinc Plated STL=Steel ZZ=Zamak

EXPLODED VIEW

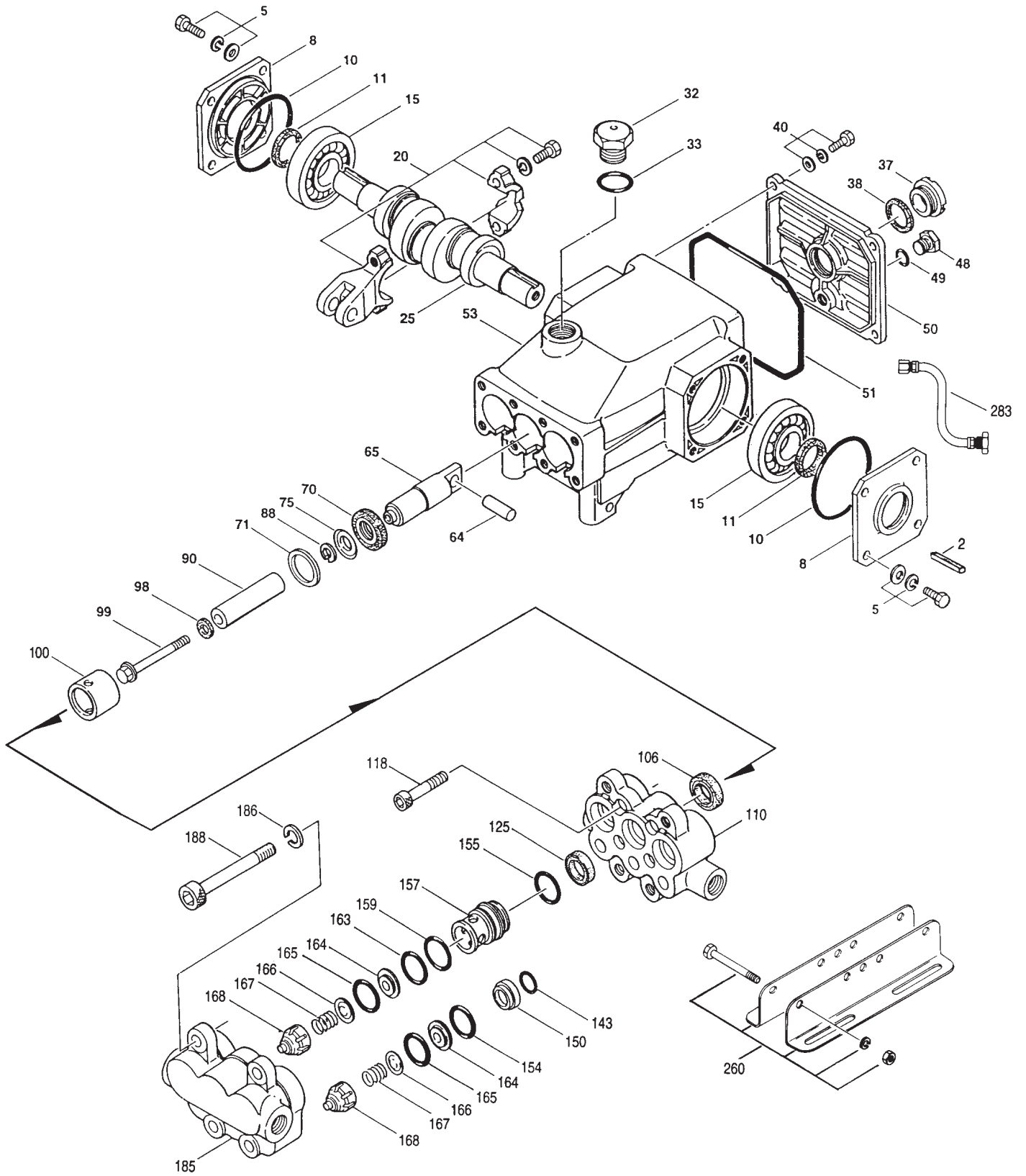

Models
5CP6121, 5CP6141, 5CP6151
April 1998

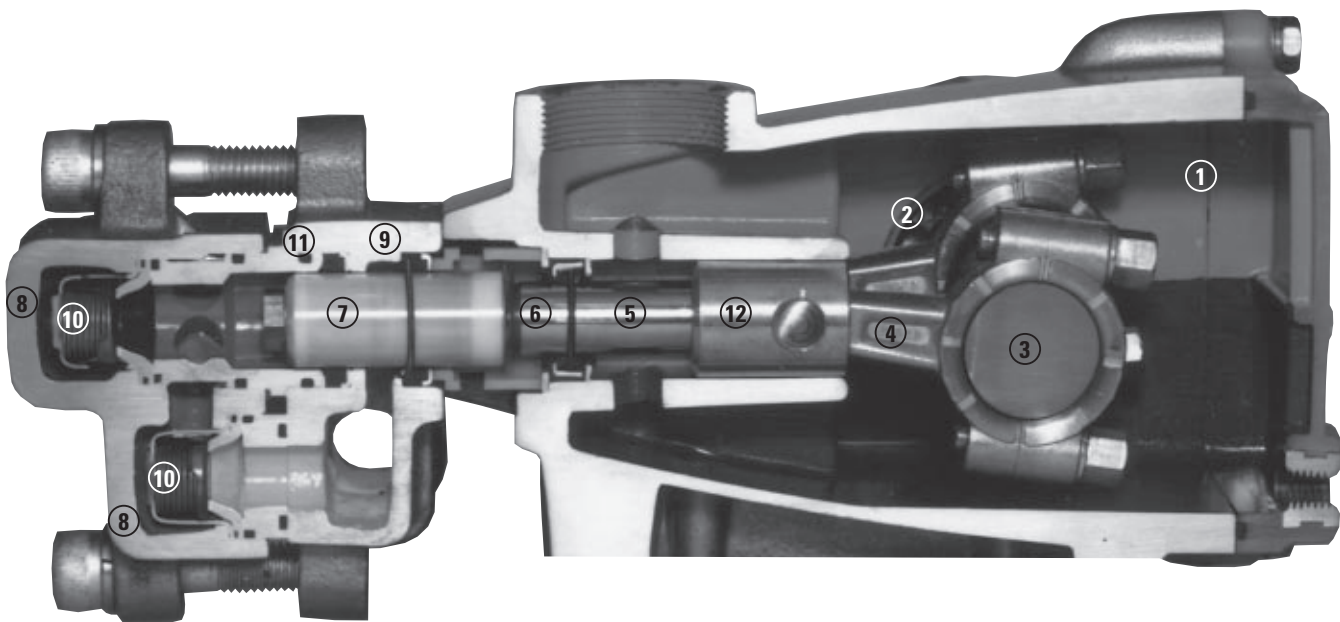
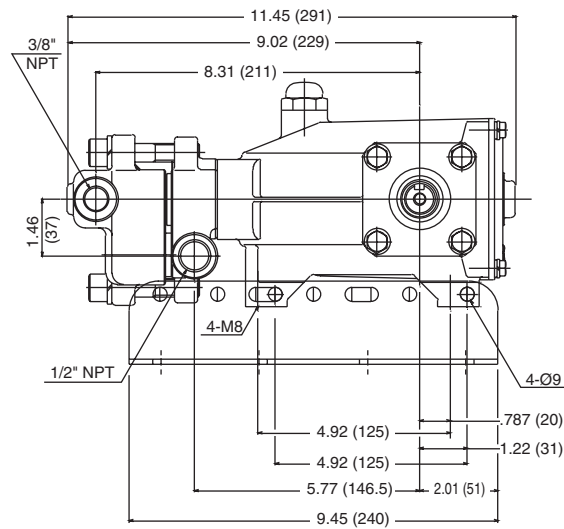
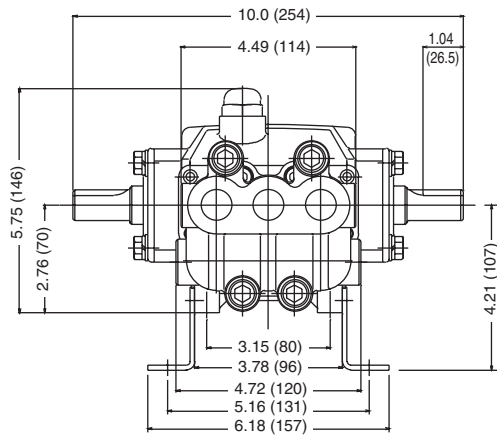

- 1 Die cast aluminum **crankcase** means high strength, lightweight, and excellent tolerance control.
- 2 Oversized crankshaft **bearings** provide extended bearing life and pump performance.
- 3 Chrome-moly **crankshaft** provides unmatched strength and surface hardness for long life.
- 4 Matched high strength **connecting rods** noted for strength and superior bearing quality.
- 5 The **plunger rods** are hardened, surface plated for wear resistance, with high load capacity.
- 6 The stainless steel **slinger** provides back-up protection for the crankcase seal, keeping pumped fluids out of the crankcase.
- 7 Special concentric, high density, polished, graphite impregnated, solid ceramic **plungers** are abrasion resistant and result in extended seal life.
- 8 **Manifolds** are high tensile strength 316 stainless steel for fluid compatibility and long term, continuous duty.
- 9 100% wet **seal** design adds to service life by allowing pumped fluids to cool and lubricate on both sides.
- 10 316 stainless steel **valves, seats and springs** provide corrosion-resistance, positive seating and long life.
- 11 Specially formulated, CAT PUMP exclusive, **Hi-Pressure Seals** offer unmatched performance and seal life.
- 12 **Crossheads** are 360° supported for uncompromising alignment.

Apr 1998 10771

World Headquarters

CAT PUMPS

1681 - 94th Lane N.E. Minneapolis, MN 55449-4324

Phone (612) 780-5440 — FAX (612) 780-2958

e-mail: sales@catpumps.com

www.catpumps.com

International Inquiries

FAX (612) 785-4443

e-mail: intlsales@catpumps.com



The Pump with "Nine Lives"

CAT PUMPS (U.K.) LTD.

1 Fleet Business Park, Sandy Lane, Church Crookham, Fleet

Hampshire GU13 0BF, England

Phone Fleet 44 1252-622031 — Fax 44 1252-626655

N.V. CAT PUMPS INTERNATIONAL S.A.

Heiveldekens 6A, 2550 Kontich, Belgium

Phone 32-3-450.71 50 — Fax 32-3-450.71 51

e-mail: cpi@catpumps.be

CAT PUMPS DEUTSCHLAND GmbH

Buchwiese 2, D-65510 Idstein, Germany

Phone 49 6126-93030 — Fax 49 6126-930333

e-mail: catpumps@t-online.de