



## **5K Series - Single Stage Stainless Steel End-Suction Centrifugal Pumps**

**Self-Priming Models**

# 5K111-5K123

### **FEATURES**

- 304SSL liquid-end construction offers corrosion resistance and increases operating life over typical cast iron models.
- Unique bulge formed components eliminates harsh radius and welds and provides greater efficiency and durability.
- Back pullout design permits easy repair of impeller and seal.
- High quality mechanical shaft seal and o-rings for a variety of standard or high temperature and chemical duty applications.
- Under casing foot mount and centerline discharge reduces misalignment and assures self-venting.
- Close coupled, motorized packages for compact and easy installation.
- Durable Noryl/Fiberglass Diffuser.

### **SPECIFICATIONS**

	U.S. Measure
Flow Range	.....1.5 to 18.5 GPM
Pressure Range	.....27 to 82 PSI
	.....63 to 190 Ft. Head
Max. Suction Lift	.....25 Feet
Max. Working Pressure	.....85 PSI
RPM	.....3450 RPM
Inlet Fitting	All Models.....1.25" NPTF
Discharge Fitting	All Models.....1" NPTF
Horsepower Range	.....1 to 2 HP
Motor Options	56J Frame TEFC Class F
	1.0HP.....115/208-230V, 1 PH, 60 HZ
	2.0HP.....115/208-230V, 1 PH, 60 HZ
	1.0HP.....208-230/460V, 3 PH, 60 HZ
	2.0HP.....208-230/460V, 3 PH, 60 HZ
Cycle	.....60 HZ
Max. Temperature*	Continuous ..... 113°F
Weight (Pump Only)	.....8.95 Lbs.
Dimensions	Pump Only (see chart) .....7.63 x 8.19"

\*Contact CAT PUMPS for applications above 113°F.

*“Customer confidence is our greatest asset”*

# EXPLODED VIEW

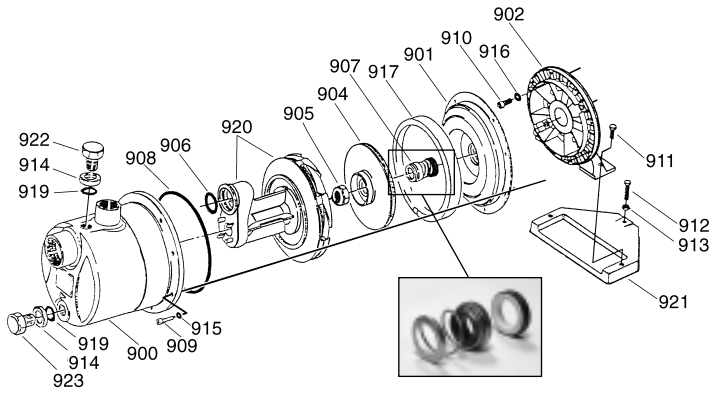

# PARTS LIST

ITEM	P/N	MATL	DESCRIPTION	QTY
900	—	S	Casing	1
901	—	S	Cover, Casing	1
902	—	AL	Bracket	1
904	—	S	Impeller, 5K111 (4.500")	1
	—	S	Impeller, 5K121 (5.187")	1
905	—	S	Nut, Impeller	1
906	899248	FPM	O-Ring, Diffuser - 75D	1
907	899001	NCC	Seal, Shaft Assy-Standard	1
	899002	FCC	Seal, Shaft Assy-Mild Chemical	1
	899003	HCC	Seal, Shaft Assy-High Temp	1
908	899250	FPM	O-Ring, Case	1
909	—	S	Screw, Socket (M6x16)	8
910	—	S	Screw, Socket (3/8-16x1")	4
911	—	S	Screw, Hex (M8x16)	2
912	—	S	Screw, Hex (M8x32 and M8X45)	1/1
913	—	S	Nut, Hex (M8)	1
914	—	S	Washer, Plug	2
915	—	S	Lockwasher, Toothed (M6)	8
916	—	S	Lockwasher, Toothed (3/8")	4
917	899267	RTP	Vane, Guide	1
919	899252	FPM	O-Ring, Plug - 75D	2
920	899277	RTP	Diffuser	1
921	—	STL	Base	1
922	—	S	Plug, Prime, Case	1
923	—	S	Plug, Drain, Case	1

*Italics are optional items.*

MATERIAL CODES (Not Part of Part Number):

AL=Aluminum FCC=Carbon/Ceramic/FPM FPM=Fluorocarbon  
 HCC=Carbon/Ni/Resist/FPM NCC=Carbon/Ceramic/Buna  
 RTP=Reinforced Composite S=304SS STL=Steel

# DIMENSIONAL

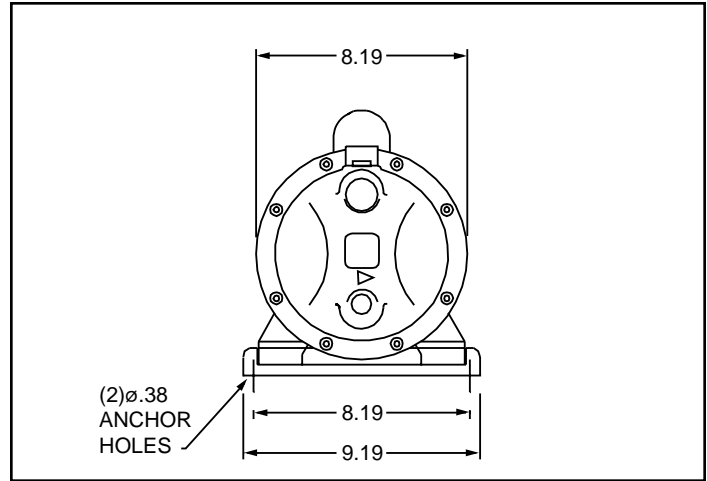
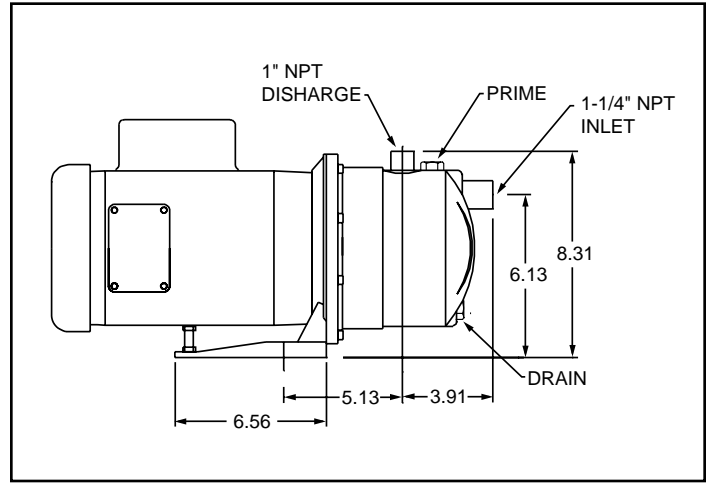

3450 RPM MPU								
Pump Model	Motor P/N	Motor wt (lbs)	MPU Lgth (in)	MPU wt (lbs)	Motor P/N	Motor wt (lbs)	MPU Lgth (in)	MPU wt (lbs)
	1PH	1PH	1PH	1PH	3PH	3PH	3PH	3PH
5K111-13	899169	33.00	18.43	41.95	899173	29.00	16.68	37.95
5K121-23	899176	44.00	19.04	52.95	899177	37.00	18.43	45.95

### PUMP CODES:

Last digit of Pump Kit is Seal Assembly type

- 1 = NCC Standard Seal Assy (Carbon/Ceramic/Buna) **Standard Service**
- 2 = FCC Alternate Seal Assy (Carbon/Ceramic/FPM) **Mild Chemical**
- 3 = HCC Alternate Seal Assy (Carbon/Ni/Resist/FPM) **High Temperature**

### MPU CODES:

Last digit of MPU is Motor Phase and Voltage

- |                  |                  |
|------------------|------------------|
| Single Phase     | Three Phase      |
| 0 = 115/208-230V | 3 = 208-230/460V |
| 1 = 115/230V     | 4 = 230/460V     |
| 2 = 230V         | 5 = 575V         |
|                  | 6 = 380V         |

# SELECTION CHART - 3450 RPM

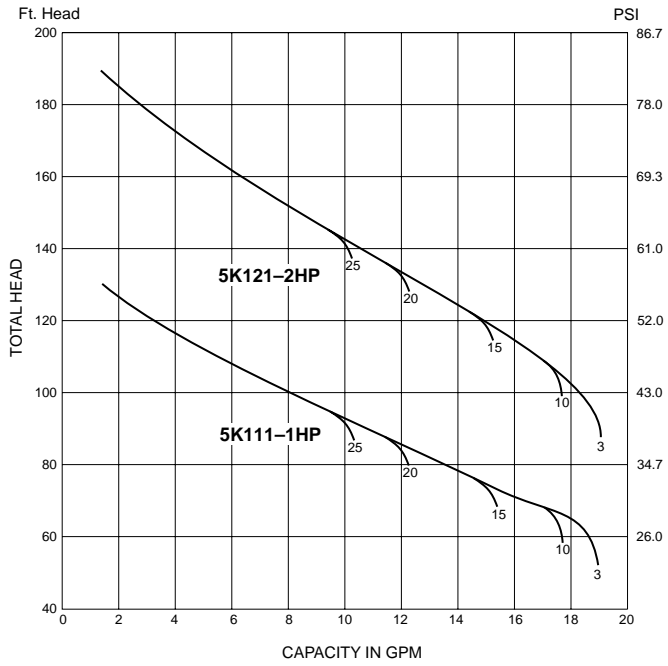

NOTE: Figures in selection chart indicate suction lift (Ft.).

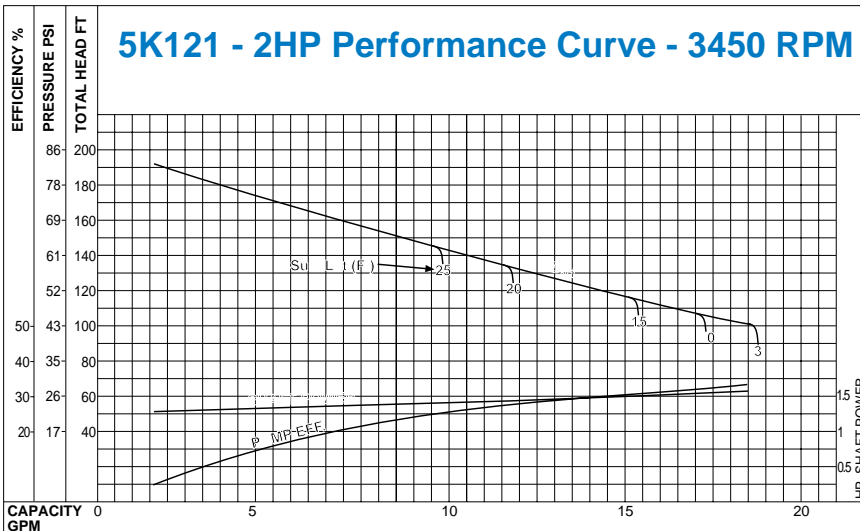
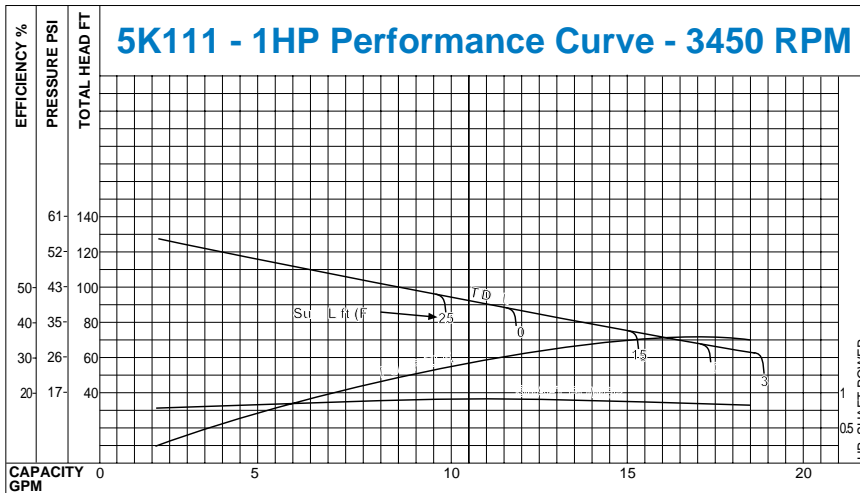

All calculations based upon water @ Spec. Gravity of 1.00 @ 68°F

# GENERAL SAFETY AND OPERATION

**SELECTION:** Review the Selection Chart to find the performance range and pump model suited to your application requirements. Then review the Performance Curve Chart to verify the most efficient performance and inlet conditions required.

**INSTALLATION:** These pumps may be installed in either a horizontal (most common) or vertical position (as installation requires). The following criteria should be considered to assure optimum performance:

- Proper alignment of plumbing
- Adequate line size to prevent starvation
- Rigid metal or plastic pipe or reinforced flexible plumbing to prevent collapsing lines
- Properly sealed connections to prevent air leaks
- Good filtration of the liquid to avoid abrasives and solids
- Foot valve may need to be installed at the inlet

**OPERATION:** The pump comes with a standard seal for fresh water or non harsh liquids. Excessive pH, high viscosity and abrasives will affect the life and performance of the pump. Special shaft seals are available for high temperature or chemical duty applications. Check with CAT PUMPS for high viscosity liquids. Make certain there is sufficient liquid supply to the pump before starting operation.

**MAINTENANCE:** This is a low maintenance pump. The shaft seal and impeller are the primary service items. These can be easily replaced.

1. Remove the 8 socket head screws and toothed lockwashers. Separate the casing from the casing cover.
2. Remove the impeller nut and unthread the impeller.
3. Carefully pry the casing cover away from the bracket.
4. Place the casing cover on a work surface (large diameter up) and press out the shaft seal.
5. Turn the casing cover over on the work surface (small diameter up) and press the **back half** (stationary half) of the new shaft seal into position until completely seated in the chamber with the **elastomer side down**.

### CAUTION

Exercise care when handling the shaft seal. It can be easily contaminated by improper handling and will not properly seal. Use the paper cover to press the seal into position and toss the cover when done.

NOTE: If seal installation is tight, carefully apply a small amount of lubricant to the **outer edge** (non-chlorine dish soap). **DO NOT USE OIL OR GREASE.**

6. Align the casing cover with the holes on the bracket and press into position.

7. Slide the **front half** of the seal (rotating half) onto the shaft with the **elastomer side out** (carbon/ceramic surfaces mating). Then slide the seal spring and washer onto the shaft.
8. Hold the seal spring in place and thread the impeller into position until completely seated.  
NOTE: Use a screwdriver to hold the motor shaft stationary.
9. Install the impeller hex nut onto the shaft and torque per chart.  
NOTE: Apply loctite to the impeller nut before installing.  
NOTE: Rotate the impeller to assure proper alignment before installing the cover.
10. Place the new O-Ring over the casing cover. Exercise caution not to cut or twist the O-Ring during installation.
11. Replace the casing. Rotate to desired discharge port position and align holes. Replace 8 lockwashers and socket screws and torque per chart.

### TORQUE CHART

	Size	Torque	
		ft. lbs.	in. lbs. Nm
<b>Impeller Nut</b>	7/16-20	12-18	144-216 16-24
<b>Pump Casing</b> (To Motor Bracket)	M6 x 16 Socket Head Cap Screw M6 Ext. Tooth Lockwasher	3.4	41 4.6
<b>Motor Bracket</b> (To Motor)	3/8" -16 x 1" Socket Head Screw 3/8" Ext. Tooth Lockwasher	6.0	72 10.8
<b>Motor Bracket</b> (To Motor Base)	M8 x 16 Hex Head Cap Screw	4.0	48 5.4
<b>Motor Stand Support</b>	M8 x 30 or M8 x 45 Hex Head Cap Screw M8 Hex Nut	No Requirements (Adjust to Support Motor/Variable)	

### TROUBLESHOOTING

PROBLEM	SOLUTION
• No flow or low flow	• Check rotation of pump • Check liquid supply to pump
• Leaking	• Replace shaft seal • Check case cover o-ring
• Noise	• Check liquid supply to pump • Check viscosity of liquid • Review NPSH requirements
• Vibration	• Secure plumbing to and from pump • Check impeller and replace as needed

### WARRANTY

**This pump is warranted for one year from date of purchase.**  
Improper installation and use will void the warranty.

## World Headquarters

### CAT PUMPS

1681 - 94th Lane N.E. Minneapolis, MN 55449-4324

Phone (763) 780-5440 — FAX (763) 780-2958

e-mail: techsupport@catpumps.com

www.catpumps.com

## International Inquiries

FAX (763) 785-4329

e-mail: intlsales@catpumps.com



*The Pumps with Nine Lives*

## CAT PUMPS (U.K.) LTD.

1 Fleet Business Park, Sandy Lane, Church Crookham, Fleet

Hampshire GU52 8BF, England

Phone Fleet 44 1252-622031 — Fax 44 1252-626655

e-mail: sales@catpumps.co.uk

## N.V. CAT PUMPS INTERNATIONAL S.A.

Heiveldekens 6A, 2550 Kontich, Belgium

Phone 32-3-450.71.50 — Fax 32-3-450.71.51

e-mail: cpi@catpumps.be www.catpumps.be

## CAT PUMPS DEUTSCHLAND GmbH

Buchwiese 2, D-65510 Idstein, Germany

Phone 49 6126-9303 0 — Fax 49 6126-9303 33

e-mail: catpumps@t-online.de www.catpumps.de