

Optional Oilers Shown

60 Frame Piston Pump

Models

6024 6044

FEATURES

Superior Design

- Triplex Uniflow design provides continuous forward liquid flow for smooth operation.
- Wetted cups and floating pistons are lubricated and cooled by pumped liquid for long cup life.
- Mechanically actuated inlet valves give strong lift and easy prime.
- Oil bath crankcase assures optimum lubrication.

Quality Materials

- Cylinder and sleeve wear surfaces are hard chrome plated 304 stainless steel for maximum durability and abrasion resistance.
- Chrome plated, brass manifolds and optional 316 stainless steel manifolds are strong and corrosion resistant.
- Precision design 304 stainless steel valves and seats are hardened and polished for ultimate seating and extended valve life.
- Chrome-moly crankshaft gives unmatched strength and surface hardness.
- Oversized crankshaft bearings with greater loading capacity mean longer bearing life.

Easy Maintenance

- Stepped stainless steel piston rod with chrome-plated, stainless steel sleeve allows easy replacement from front of pump.
- All wet-end wear parts are easily serviced without entering crankcase, requiring less time and effort.
- Wear parts are available in convenient kits.

⚠ WARNING

All systems require both a primary pressure regulating device (i.e., regulator, unloader) and a secondary pressure safety relief device (i.e., pop-off valve, safety valve). Failure to install such relief devices could result in personal injury or damage to the pump or to system components. CAT PUMPS does not assume any liability or responsibility for the operation of a customer's high pressure system.

SPECIFICATIONS

U.S. Measure

Metric Measure

MODEL 6024

Flow	12 GPM	(45 L/M)
Pressure Range.....	100 to 5000 PSI	(7 to 345 BAR)
RPM	500 RPM	(500 RPM)
Bore.....	1.5"	(38 mm)

MODEL 6044

Flow	20 GPM	(76 L/M)
Pressure Range.....	100 to 3000 PSI	(7 to 210 BAR)
RPM	500 RPM	(500 RPM)
Bore.....	1.85"	(47 mm)

COMMON SPECIFICATIONS

Stroke.....	2.480"	(63 mm)
Crankcase Capacity.....	10 Qts.	(9.46 L)
Maximum Liquid Temperature	140°F	(60°C)

Above 130 F call CAT PUMPS for inlet conditions and elastomer recommendations.

Inlet Pressure Range	-8.5 to +40 PSI	(-0.6 to +2.8 BAR)
Inlet Ports (1)	2" NPTF	(2" NPTF)
Discharge Ports (3).....	1" NPTF	(1" NPTF)
Pulley Mounting	Either Side	(Either Side)
Shaft Diameter	1.772"	(45 mm)
Weight.....	265 lbs.	(120 kg)
Dimensions.....	35.2 x 24.0 x 17.1"	(895 x 610 x 434 mm)

ELECTRIC HORSEPOWER REQUIREMENTS

Model	FLOW		PRESSURE					RPM	DRIVE	
	U.S. GPM	L/M	PSI 2000	PSI 2500	PSI 3000	PSI 4000	PSI 4500			PSI 5000
6024	12	45	N/A	N/A	N/A	32.9	37.1	41.1	500	Consult CAT PUMPS for Pump and Motor Pulley Sizes
	11	42	N/A	N/A	N/A	30.1	34.0	37.7	458	
	10	38	N/A	N/A	N/A	27.4	30.9	34.2	417	
6044	20	76	27.4	34.2	41.1	N/A	N/A	N/A	500	
	18	68	24.7	30.9	36.9	N/A	N/A	N/A	450	
	16	61	22.0	27.5	33.0	N/A	N/A	N/A	400	

DETERMINING THE PUMP R.P.M.	$\frac{\text{Rated G.P.M.}}{\text{Rated R.P.M.}}$	=	$\frac{\text{"Desired" G.P.M.}}{\text{"Desired" R.P.M.}}$
DETERMINING THE REQUIRED H.P.	$\frac{\text{GPM x PSI}}{1460}$	=	Electric Brake H. P. Required
DETERMINING MOTOR PULLEY SIZE	$\frac{\text{Motor Pulley O.D.}}{\text{Pump R.P.M.}}$	=	$\frac{\text{Pump Pulley O.D.}}{\text{Motor R.P.M.}}$

See complete Drive Packages [Inclds: Pulleys, Belts, Hubs, Key] Tech Bulletin 003. Refer to pump **Service Manual** for repair procedure, additional technical information and **pump warranty**.

"Customer confidence is our greatest asset"

PARTS LIST

ITEM	PART NUMBER		DESCRIPTION	QTY		
	6024	MATL	6044	MATL		
2	43048	STL	43048	STL	Key (M14x9x90)	1
5	80296	STZP	80296	STZP	Screw, HH (M10x40)	8
6	12503	STZP	12503	STZP	Lockwasher (M10)	8
7	12490	STZP	12490	STZP	Washer, Flat (M10)	8
8	29443	AL	29443	AL	Cover, Outer Bearing	2
10	29444	NBR	29444	NBR	O-Ring, Bearing Cover - 70D	2
11	11443	NBR	11443	NBR	Seal, Oil - 70D	2
12	43642	S	43642	S	Washer, Shim	2
13	43643	S	43643	S	Washer, Shim	2
15	29441	STL	29441	STL	Bearing, Roller	2
16	29442	STL	29442	STL	Cover, Inner Bearing	2
17	29444	NBR	29444	NBR	O-Ring, Bearing Cover - 700	2
20	115983	BBHS	115983	BBHS	Rod, Connecting	3
21	44941	STZP	44941	STZP	Washer, Locking	3
22	43641	STZP	43641	STZP	Washer, Shim (M10.5x1.5) Replace as a set	6
25	29440	FCM	29440	FCM	Crankshaft	1
31	828710	—	828710	—	Protector, Oil Cap	1
32	43211	ABS	43211	ABS	Cap, Oil Filler	1
33	14177	NBR	14177	NBR	O-Ring, Filler Cap - 70D	1
34	44319	STZP	44319	STZP	Bolt, Eye	1
38	11338	NBR	11338	NBR	O-Ring, Dip Stick - 70D	1
39	27769	ABS	27769	ABS	Stick, Dip	1
40	80288	STZP	80288	STZP	Screw, HH (M10x30)	6
41	12503	STZP	12503	STZP	Lockwasher (M10)	6
42	12490	STZP	12490	STZP	Washer, Flat (M10)	6
48	25625	STCP	25625	STCP	Plug, Drain (1/4"x19BSP)	1
49	23170	NBR	23170	NBR	O-Ring, Drain Plug - 70D	1
50	29438	AL	29438	AL	Cover, Rear	1
51	29439	NBR	29439	NBR	Gasket, Rear Cover	1
53	43284	AL	43284	AL	Crankcase	1
55	85449	STZP	85449	STZP	Stud (M16x72)	4
64	29481	CM	29481	CM	Pin, Crosshead	3
65	43002	SZZ	43002	SZZ	Rod, Piston	3
69	29453	STZP	29453	STZP	Washer, Oil Seal	3
70	29454	NBR	29454	NBR	Seal, Oil, Crankcase - 80D	3
75	29340	S	29340	S	Slinger, Barrier	3
77	11345	NBR	11345	NBR	O-Ring, Sleeve - 70D	6
	11375	FPM	11375	FPM	O-Ring, Sleeve	6
80	43129	SCP	43129	SCP	Sleeve (M25)	3
	43271	S	43271	S	Sleeve (M25)	3
81	20189	PTFE	20189	PTFE	Back-up-Ring, Sleeve	3
100	29456	AL	29456	AL	Retainer, Seal	3
101	43136	—	43136	—	Wick, Oil (M25)	3
106	43130	NBR	43130	NBR	Seal, LPS, Ungreased (M25)	3
	43132	FPM	43132	FPM	Seal, LPS, Ungreased (M25)	3
110	43283	BBCP	43283	BBCP	Manifold, Inlet	1
	29805	SS	29805	SS	Manifold, Inlet	1
119	43010	S	43029	S	Valve, Inlet	3
123	12392	NBR	12392	NBR	O-Ring, Cylinder - 70D	3
	13279	FPM	13279	FPM	O-Ring, Cylinder - 70D	3
124	43004	BBCP	43021	BBCP	Cylinder	3
	43118	S	43119	S	Cylinder	3
125	43005	BB	43022	BB	Spacer, Female Adapter	3
	43127	S	—	—	Spacer, Female Adapter	3
126	43006	PTFE	43023	PTFE	Adapter, Female	3
127	26592	PTFE	43024	PTFE	V-Packing	12
128	26589	PTFE	43025	PTFE	Adapter, Male	3
129	27828	BB	43026	BB	Spacer, Male Adapter	3
	43120	S	43121	S	Spacer, Male Adapter	3
130	43011	SCP	43030	SCP	Piston (Sleeve-Type)	3
	30788	S	30768	S	Piston (Sleeve-Type)	3
135	43012	S	43012	S	Spacer (Sleeve-Type), Piston	3
136	43013	S	43031	S	Retainer, Piston	3
137	88579	S	88579	S	Washer, Conical (M10)	3
138	29505	S	29505	S	Nut, Slotted (M10)	3
139	29354	S	29354	S	Cotterpin	3
141	43007	S	43027	S	Spring, V-Packing	3
155	13429	NBR	25495	NBR	O-Ring, Adapter, Inner	3
	28773	FPM	11748	FPM	O-Ring, Adapter, Inner	3
156	43008	PTFE	48371	D	Back-up-Ring, Adapter, Inner	3
157	43009	S	43028	S	Adapter	3
158	43008	PTFE	43008	PTFE	Back-up-Ring, Adapter, Outer	3
159	13429	NBR	13429	NBR	O-Ring, Adapter, Outer	3
	28773	FPM	28773	FPM	O-Ring, Adapter, Outer	3
162	43064	PTFE	43064	PTFE	Back-up-Ring, Seat	3
163	43015	NBR	43015	NBR	O-Ring, Seat - 70D	3
	43194	FPM	43194	FPM	O-Ring, Seat - 70D	3
164	43014	S	43014	S	Seat	3
166	19393	S	19393	S	Valve	3
167	43016	S	43016	S	Spring	3
168	43117	S	43117	S	Retainer, Spring	3
183	88901	STZP	88901	STZP	Stud (M16x385)	4
185	43017	SS	43017	SS	Manifold, Discharge	1
186	12504	STZP	12504	STZP	Lock Washer (M16)	12
187	43018	STZP	43018	STZP	Bolt, Cylinder (M16)	4
194	88853	STCP	88853	STCP	Nut, Hex (M16)	8
196	27807	BBCP	27807	BBCP	Plug (1" NPT)	1
250	29445	AL	29445	AL	Protector, Shaft (Incl. w/Pump)	1
255	33243	STZP	33243	STZP	Mount, Direct (Incl. w/Pump)	1
259	29477	STZP	29477	STZP	Mounting Rail (Incl. w/Pump)	1

EXPLODED VIEW

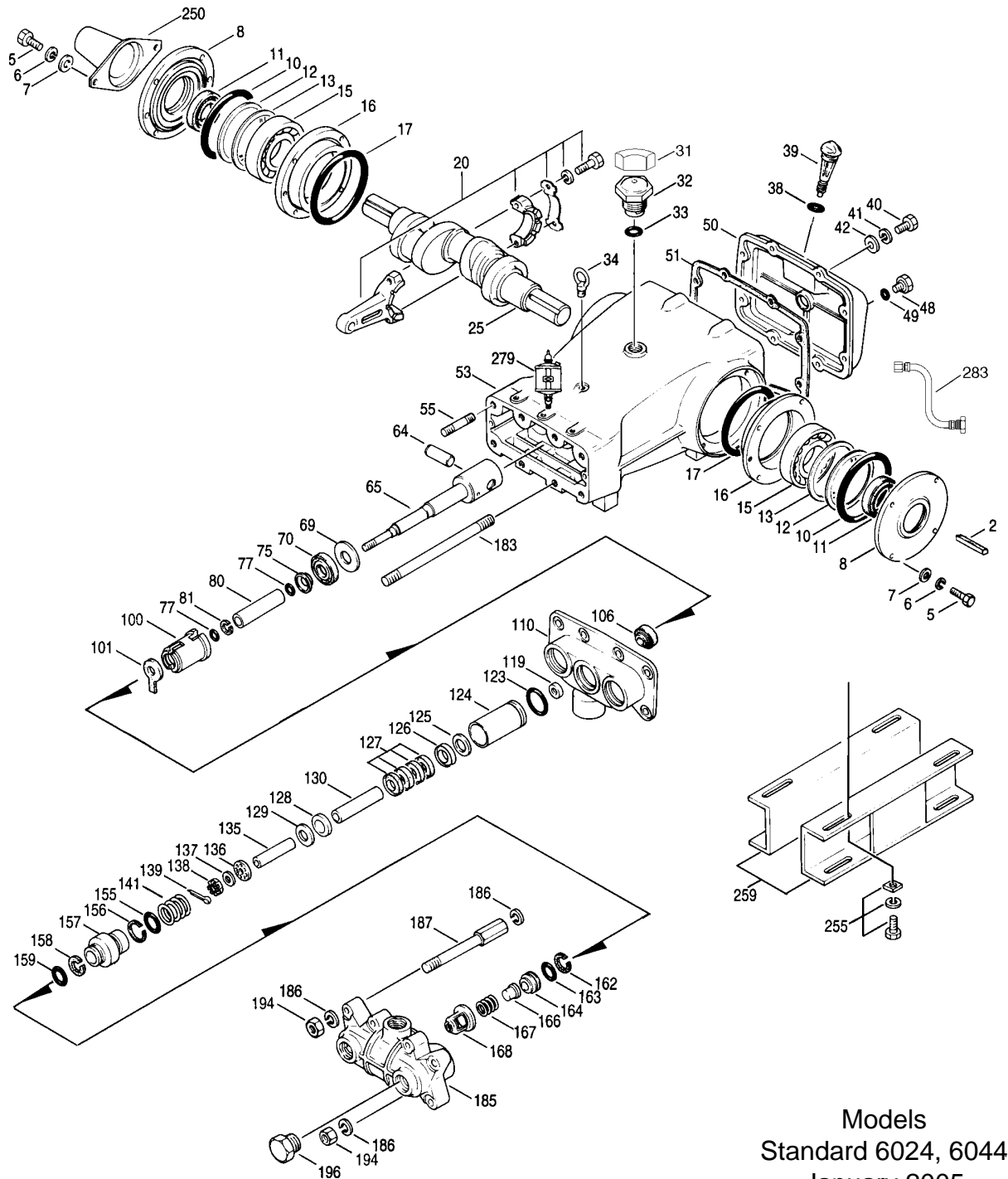

Models
Standard 6024, 6044
January 2005

	6024	MATL	6044	MATL		
275	—	—	—	—	<i>Hub & Key Assy</i> [See Drive Packages, Tech Bulletin 003]	1
279	30429	STZP	30429	STZP	<i>Oilers (10 oz.)</i>	3
280	30969	—	30969	—	<i>Oilers, Glass (10 oz.)</i>	3
281	10070	NBR	10070	NBR	<i>Gasket, Oiler (10 oz.)</i>	3
283	34334	—	34334	—	<i>Kit, Oil Drain</i>	1
302	—	—	—	—	<i>Kit, V-Packing (Select: 126,127,128,139,155,156,159)</i>	1
306	30484	NBR	30484	NBR	<i>Kit, Seal (Incls: 101,106,139)</i>	1
310	—	—	—	—	<i>Kit, Valve (Select: 155,159,162,163,164,166,167,168)</i>	1
—	714500	SS	714500	SS	<i>C.A.T. (Captive Acceleration Tube)</i>	1
—	714508	SS	714508	SS	<i>Adapter (2 per C.A.T.) (See Data Sheet for complete selection)</i>	2
—	6105	—	6105	—	<i>Oil, Twin Pack (Two 2.5 gal.) ISO 68 Multi-viscosity Hydraulic (Fill to specified crankcase capacity prior to start-up)</i>	1

Bold print part numbers are unique to a particular pump model. Italics are optional items.

C. A. T. highly recommended for pressurized inlet, R.O. and Industrial applications.

See Tech Bulletins 002, 003, 012, 024, 034, 036, 064, 074, 077, 083 and 084 for additional information.

MATERIAL CODES (Not Part of Part Number): ABS=ABS Plastic AL=Aluminum BB=Brass BBPC=Brass/Chrome Plated BBHS= Brass/High Strength CM=Chrome-moly D=Acetal FCM=Forged Chrome-moly FPM=Fluorocarbon NBR=Medium Nitrile (Buna-N) PTFE=Pure Polytetrafluoroethylene S=304SS SCP=304SS/Chrome Plated SS=316SS STCP=Steel/Chrome Plated STL=Steel STZP=Steel/Zinc Plated SZZ=304SS/Zamak

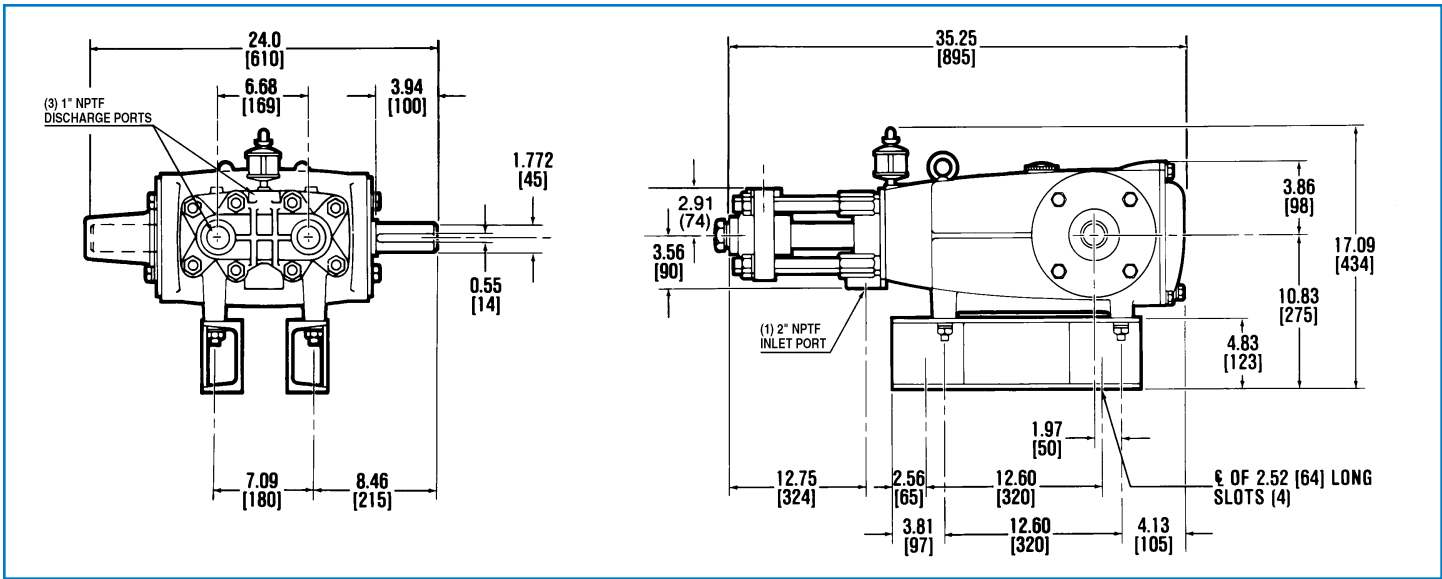

Models 6024, 6044

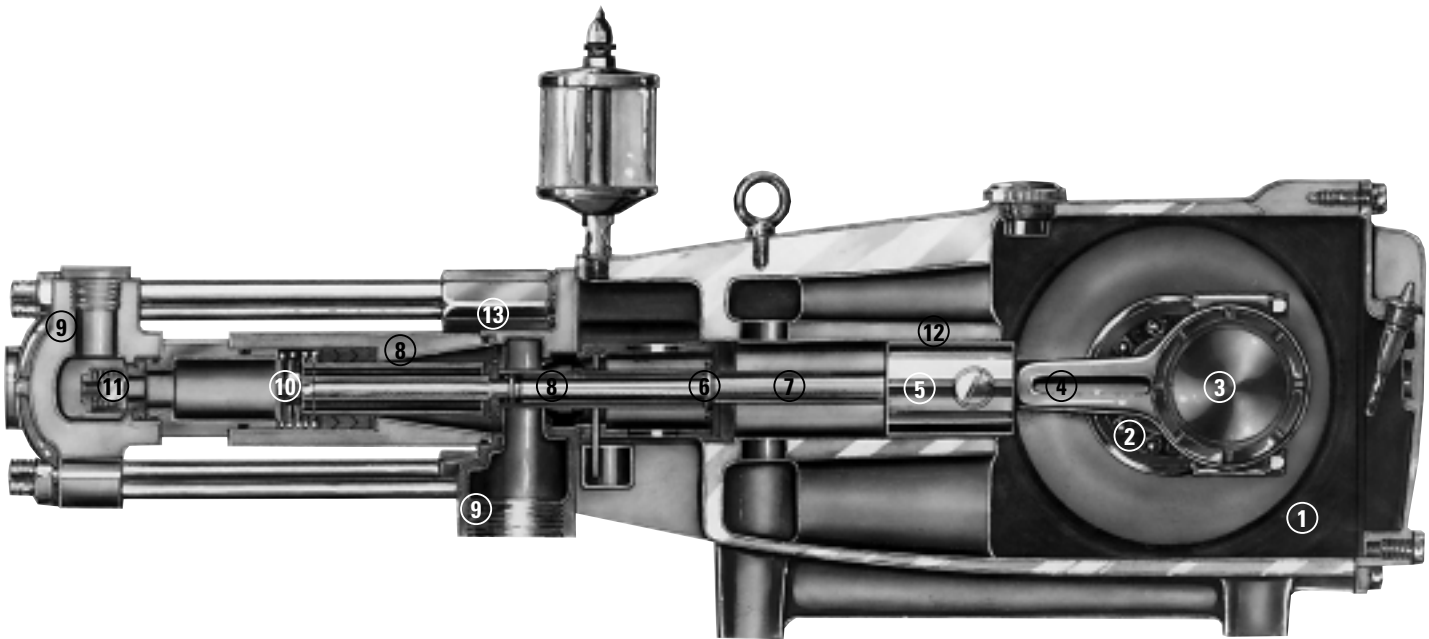

- 1 Die cast aluminum **crankcase** means high strength, lightweight, and excellent tolerance control.
- 2 Oversized crankshaft **bearings** provide extended bearing life and pump performance.
- 3 Chrome-moly **crankshaft** provides unmatched strength and surface hardness for long life.
- 4 Matched oversized high strength **connecting rods** are noted for superior tensile strength and bearing quality.
- 5 The **piston rods** are high tensile strength 316 stainless steel with Zamak crossheads.
- 6 The stainless steel **slinger** provides back-up protection for the crankcase seal, keeping pumped liquids out of the crankcase.
- 7 The **patented stepped piston rod** with stainless steel **sleeves** provides a durable wear surface and easy wet-end servicing.
- 8 The **cylinder** and **sleeve** wear surfaces are hard chrome-plated 304 stainless steel for longer service life.
- 9 **Manifolds** are of high tensile strength chrome-plated brass or 316 stainless steel for special corrosion resistance.
- 10 100% wet **seal** design adds to service life by allowing pumped liquids to cool and lubricate the elastomers on both sides.
- 11 304 stainless steel **valves, seats, and springs** provide corrosion-resistance, ultimate seating and extended life.
- 12 **Crossheads** are 360° supported for uncompromising alignment.
- 13 Mechanically actuated **inlet valves** provide strong lift and easy prime.

World Headquarters

CAT PUMPS

1681 - 94th Lane N.E. Minneapolis, MN 55449-4324

Phone (763) 780-5440 — FAX (763) 780-2958

e-mail: techsupport@catpumps.com

www.catpumps.com

International Inquiries

FAX (763) 785-4329

e-mail: intl@catpumps.com



The Pumps with Nine Lives

CAT PUMPS (U.K.) LTD.

1 Fleet Business Park, Sandy Lane, Church Crookham, Fleet

Hampshire GU52 8BF, England

Phone 32-3-450.71.50 — Fax 44 1252-626655

e-mail: sales@catpumps.co.uk

N.V. CAT PUMPS INTERNATIONAL S.A.

Heiveldekens 6A, 2550 Kontich, Belgium

Phone 32-3-450.71.50 — Fax 32-3-450.71.51

e-mail: cpi@catpumps.be www.catpumps.be

CAT PUMPS DEUTSCHLAND GmbH

Buchwiese 2, D-65510 Idstein, Germany

Phone 49 6126-9303 0 — Fax 49 6126-9303 33

e-mail: catpumps@t-online.de www.catpumps.de