



Model 820 shown

FEATURES

Superior Design

- Triplex Uniflow design provides continuous forward liquid flow for smooth operation.
- Wetted cups and floating pistons are lubricated and cooled by pumped liquid for long cup life.
- Mechanically actuated inlet valves give strong lift and easy prime.
- Oil bath crankcase assures optimum lubrication.
- 100% wetted seal design allows pumped liquid to cool and lubricate for longer life.

Quality Materials

- Cylinder and sleeve wear surfaces are hard chrome plated 304 stainless steel for maximum durability and abrasion resistance.
- Chrome plated, brass manifolds and optional stainless steel manifolds are strong and corrosion resistant.
- Special high strength TNM connecting rods offer superior bearing quality strength.
- Chrome-moly crankshaft gives unmatched strength and surface hardness.
- Oversized crankshaft bearings with greater loading capacity mean longer bearing life.

Easy Maintenance

- Stepped stainless steel piston rod with chrome plated, stainless steel sleeve allows easy replacement from front of pump.
- All wet-end wear parts are easily serviced without entering crankcase, requiring less time and effort.
- Wear parts are available in convenient kits.

⚠ WARNING

All systems require both a primary pressure regulating device (i.e., regulator, unloader) and a secondary pressure safety relief device (i.e., pop-off valve, safety valve). Failure to install such relief devices could result in personal injury or damage to the pump or to system components. CAT PUMPS does not assume any liability or responsibility for the operation of a customer's high pressure system.

10 Frame Piston Pump

Standard Brass Models	623, 820, 1010
Stainless Steel Models	621, 821, 1011
Pulse Pump Manifold Models	625, 825, 1015

SPECIFICATIONS

	U.S. Measure	Metric Measure
MODEL 623, 621, 625		
Flow	6.0 GPM	(23 L/M)
Pressure Range	100 to 1200 PSI	(7 to 85 BAR)
RPM	850 RPM	(850 RPM)
Bore	0.787"	(20 mm)
Stroke	1.122"	(28.5 mm)

MODEL 820, 821, 825		
Flow	10 GPM	(38 L/M)
Pressure Range	100 to 1000 PSI	(7 to 70 BAR)
RPM	940 RPM	(940 RPM)
Bore	0.984"	(25 mm)
Stroke	1.102"	(28 mm)

MODEL 1010, 1011, 1015		
Flow	13 GPM	(49 L/M)
Pressure Range	100 to 700 PSI	(7 to 50 BAR)
RPM	900 RPM	(900 RPM)
Bore	1.122"	(28.5 mm)
Stroke	1.102"	(28 mm)

COMMON SPECIFICATIONS

Crankcase Capacity	40 oz.	(1.2 L)
Maximum Liquid Temperature	160°F	(71°C)
Above 130°F call CAT PUMPS for inlet conditions and elastomer recommendations.		
Inlet Pressure Range	-8.5 to +40 PSI	(-0.6 to +2.8 BAR)
Inlet Ports (1)	1" NPTF	(1" NPTF)
Discharge Ports (3)	3/4" NPTF	(3/4" NPTF)
Shaft Diameter	0.984"	(25 mm)
Weight	34.6 lbs.	(15.7 kg)
Dimensions	17.28 x 11.42 x 6.30"	(439 x 290 x 160 mm)

ELECTRIC HORSEPOWER REQUIREMENTS

MODEL	FLOW		PRESSURE				MOTOR PULLEY SIZE	
	U.S. GPM	L/M	PSI 500	PSI 700	PSI 1000	PSI 1200	Using 1725 RPM Motor & Std. 10.0" Pulley	Motor Pulley O.D.
623, 621, 625	6.0	23	2.1	2.9	4.1	4.9	850	4.7
	5.0	19	1.7	2.4	3.4	4.1	709	4.0
	4.0	15	1.4	1.8	2.8	3.3	567	3.1
820, 821, 825	10.0	38	3.4	4.8	6.9	NA	940	5.3
	9.0	34	3.1	4.3	6.2	NA	846	4.8
	8.0	30	2.8	3.8	5.5	NA	752	4.3
1010, 1011, 1015	13.0	49	4.5	6.2	NA	NA	900	5.0
	10.0	38	3.4	4.8	NA	NA	692	4.3
	8.0	30	2.8	3.8	NA	NA	554	3.4

DETERMINING THE PUMP R.P.M.	<u>Rated G.P.M.</u>	=	<u>"Desired" G.P.M.</u>
	<u>Rated R.P.M.</u>		<u>"Desired" R.P.M.</u>
DETERMINING THE REQUIRED H.P.	<u>GPM x PSI</u>	=	<u>Electric Brake</u>
	1460		<u>H. P. Required</u>
DETERMINING MOTOR PULLEY SIZE	<u>Motor Pulley O.D.</u>	=	<u>Pump Pulley O.D.</u>
	<u>Pump R.P.M.</u>		<u>Motor R.P.M.</u>

See complete Drive Packages [Inclds: Pulleys, Belts, Hubs, Key] Tech Bulletin 003. Refer to pump **Service Manual** for repair procedure, additional technical information and **pump warranty**.

"Customer confidence is our greatest asset"

PARTS LIST

ITEM	PART NUMBER		DESCRIPTION	QTY	
	623	820	1010 MATL		
	621	821	1011		
	625 MATL	825 MATL	1015 MATL		
2	50146 STL	50146 STL	50146 STL	Key (M7x7x40)	1
5	92519 STZP	92519 STZP	92519 STZP	Screw, HHC Sems (M6x16)	8
	125824 STCP R	125824 STCP R	125824 STCP R	Screw, HHC Sems (M6x16)	8
8	27331 AL	27331 AL	27331 AL	Cover, Bearing	2
10	26965 NBR	26965 NBR	26965 NBR	O-Ring, Bearing Cover - 70D	2
11	27330 NBR	27330 NBR	27330 NBR	Seal, Oil, Crankshaft - 80D	2
15	47080 STL	47080 STL	47080 STL	Bearing, Ball	2
20	48733 TNM	48733 TNM	48733 TNM	Rod, Connecting, Assy [5/02]	3
25	27329 FCM	27329 FCM	27329 FCM	Crankshaft, Dual End	1
31	828710 —	828710 —	828710 —	Protector, Oil Cap w/Foam Gasket	1
32	43211 ABS	43211 ABS	43211 ABS	Cap, Oil Filler	1
33	14177 NBR	14177 NBR	14177 NBR	O-Ring, Oil Filler Cap - 70D	1
37	92241 —	92241 —	92241 —	Gauge, Oil Bubble w/Gasket - 80D	1
38	44428 NBR	44428 NBR	44428 NBR	Gasket, Flat, Oil Gauge - 80D	1
40	92520 STZP	92520 STZP	92520 STZP	Screw, HHC Sems (M6x20)	4
	126541 STCP R	126541 STCP R	126541 STCP R	Screw, HHC Sems (M6x20)	4
48	25625 STCP	25625 STCP	25625 STCP	Plug, Drain (1/4"x19BSP)	1
49	23170 NBR	23170 NBR	23170 NBR	O-Ring, Drain Plug - 70D	1
50	43491 AL	43491 AL	43491 AL	Cover, Rear	1
51	44834 NBR	44834 NBR	44834 NBR	O-Ring, Cover - 70D	1
53	44641 AL	44641 AL	44641 AL	Crankcase w/Guide Pins	1
55	126545 STCP R	126545 STCP R	126545 STCP R	Stud (M10x45)	4
56	27911 POP	27911 POP	27911 POP	Pan, Oil (use with items 100,101,106)	1
64	20251 CM	20251 CM	20251 CM	Pin, Crosshead	3
65	27337 SZZ	27337 SZZ	27337 SZZ	Rod, Piston	3
69	126585 STCP R	126585 STCP R	126585 STCP R	Washer, Oil Seal	3
70	27339 NBR	27339 NBR	27339 NBR	Seal, Oil, Crankcase - 80D	3
75	25327 S	25327 S	25327 S	Slinger, Barrier	3
77	25392 NBR	25392 NBR	25392 NBR	O-Ring, Sleeve - 70D	6
	28771 FPM	28771 FPM	28771 FPM	O-Ring, Sleeve	6
80	27340 SCP	27340 SCP	27340 SCP	Sleeve	3
	28782 S	28782 S	28782 S	Sleeve (Unchromed)	3
81	29003 PTFE	29003 PTFE	29003 PTFE	Back-up-Ring, Sleeve	3
100	27341 PVDF	27341 PVDF	27341 PVDF	Retainer, Seal	3
101	27910 —	27910 —	27910 —	Wick, Long Tab (use with items 56,100,106)	3
106	30315 NBR	30315 NBR	30315 NBR	Seal, LPS, Prrrrm-A-Lube (greased)	3
	30325 FPM	30325 FPM	30325 FPM	Seal, LPS, Prrrrm-A-Lube (greased)	3
	25153 NBR	25153 NBR	25153 NBR	Seal, Blue-Dot (ungreased) (use with items 56,100,101)	3
	100015 FPM	100015 FPM	100015 FPM	Seal, Blue-Dot (ungreased) (use with items 56,100,101)	3
110	27344 BBCP	27344 BBCP	27344 BBCP	Manifold, Inlet	1
	30247 SS	30247 SS	30247 SS	Manifold, Inlet	1
119	27347 S	27497 S	27813 S	Valve, Inlet	3
130	30543 S	27820 S	27814 S	Piston	3
131	30544 PTFE	—	—	Ring, Bac-Cup	3
133	43172 FPM	27821 FPM	27815 FPM	Cup, Piston	3
133	43474 FPM	—	—	Bac-Cup Assy (43172,30543,30544)	3
133	30340 NBR	—	—	Cup, Piston, Machined	3
133	29089 SNG	29091 SNG	29092 SNG	Cup, V-Hot (1000 PSI Max.)	3
133	30145 TG	30333 TG	30189 TG	Piston-Cup Assy (1000 PSI Max.)	3
135	27348 S	27499 S	27499 S	Spacer, Piston	3
136	27002 S	27500 S	20324 S	Retainer, Piston	3
137	27006 S	27006 S	27006 S	Washer, Conical (M6)	3
138	27000 S	27000 S	27000 S	Nut, Slotted (M6)	3
139	14158 S	14158 S	14158 S	Cotterpin (M1.6x10)	3
143	26969 NBR	26969 NBR	26969 NBR	O-Ring, Cylinder - 70D	6
	28459 FPM	28459 FPM	28459 FPM	O-Ring, Cylinder	6
150	28342 SCP	28340 SCP	28341 SCP	Cylinder (M50)	3
	28776 S	28778 S	28780 S	Cylinder (M50) (Unchromed)	3
153	28204 PTFE	28204 PTFE	—	Back-up-Ring, Cylinder	3
162	43062 PTFE	43062 PTFE	43062 PTFE	Back-up-Ring, Seat	3
163	26966 NBR	26966 NBR	26966 NBR	O-Ring, Seat - 70D	3
	28458 FPM	28458 FPM	28458 FPM	O-Ring, Seat - 70D	3
164	43428 S	43428 S	43428 S	Seat, Q.V.	3
	43063 S	43063 S	43063 S	Seat, F.V.	3
166	43721 S	43721 S	43721 S	Valve, Q.V.	3
	20262 S	20262 S	20262 S	Valve, F.V.	3
167	43251 S	43251 S	43251 S	Spring, Q.V.	3
	20265 S	20265 S	20265 S	Spring, F.V.	3
168	43429 S	43429 S	43429 S	Retainer, Spring, Q.V.	3
	43135 S	43135 S	43135 S	Retainer, Spring, F.V.	3
185	43046 BBCP	43046 BBCP	43046 BBCP	Manifold, Discharge	1
	30248 SS	30248 SS	30248 SS	Manifold, Discharge	1
	6410 BB	6410 BB	6410 BB	Manifold, Pulse Pump (1000 PSI Max.) (625,825,1015)	1
186	126593 STCP R	126593 STCP R	126593 STCP R	Washer, Shim (M10.5x1.5)	4/8
187	43047 STCP	43047 STCP	43047 STCP	Stud, Hex, Manifold "B"	4
188	126582 STCP R	126582 STCP R	126582 STCP R	Washer, Shim (M10.5x1.0)	4/8
189	126583 STCP R	126583 STCP R	126583 STCP R	Washer, Shim (M10x0.5)	4/8
190	126584 STCP R	126584 STCP R	126584 STCP R	Washer, Shim (M10x0.3)	4/8
191	27357 STZP	27357 STZP	27357 STZP	Lockwasher (M10)	4
192	12503 STZP	12503 STZP	12503 STZP	Lockwasher (M10)	4
	126231 STCP R	126231 STCP R	126231 STCP R	Lockwasher (M10)	4
194	126522 STCP R	126522 STCP R	126522 STCP R	Nut, Hex (M10x1.5)	4
196	20326 BBCP	20326 BBCP	20326 BBCP	Plug, Discharge Manifold (3/4" NPT)	1

EXPLODED VIEW

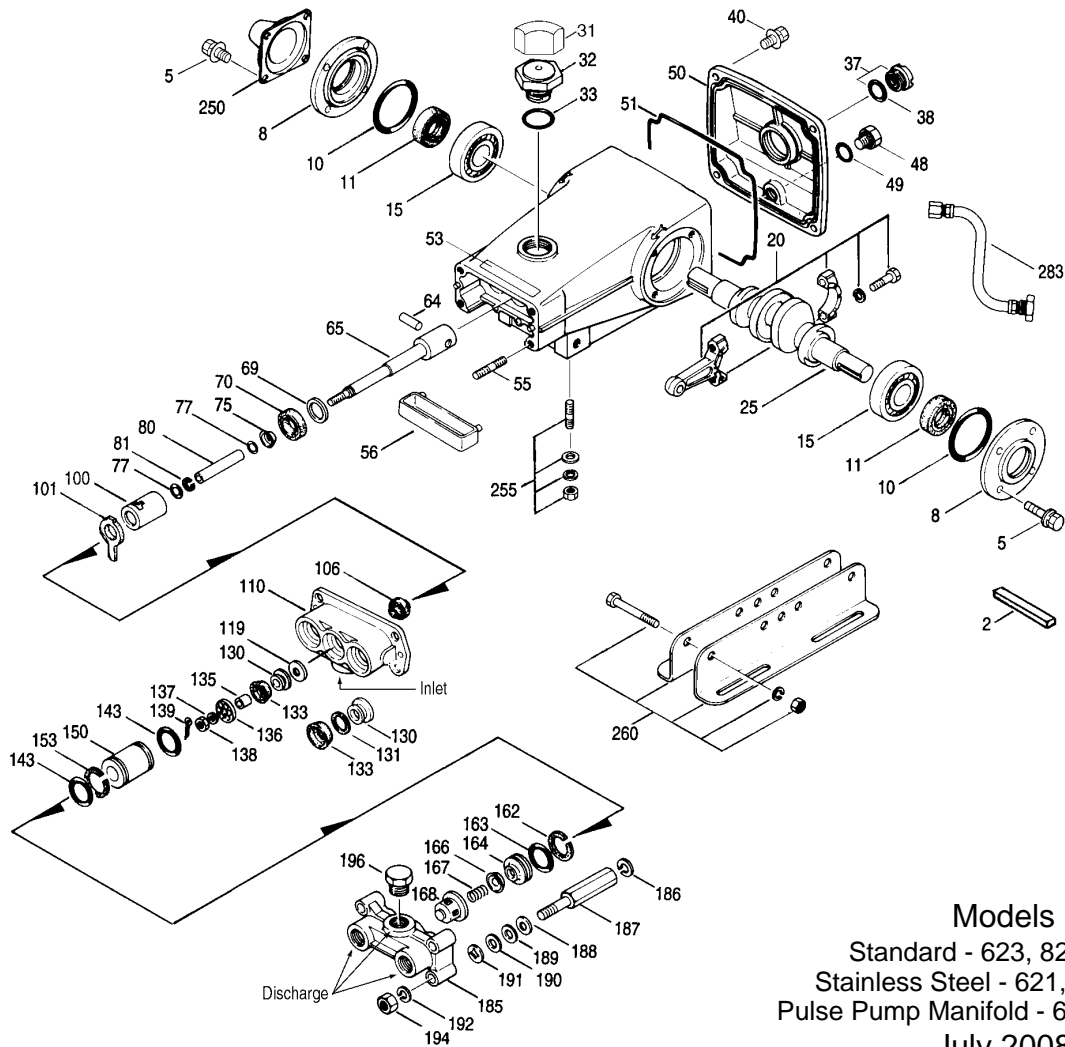

Models

Standard - 623, 820, 1010
 Stainless Steel - 621, 821, 1011
 Pulse Pump Manifold - 625, 825, 1015
 July 2008

	623		820		1010	MATL	
	621		821		1011		
	625	MATL	825	MATL	1015	MATL	
250	43139	STCP	43139	STCP	43139	STCP	Protector, Shaft
255	30264	STZP	30264	STZP	30264	STZP	Kit, Direct Mount
260	30613	STZP	30613	STZP	30613	STZP	Mount, Rail, Assy
265	30653	—	30653	—	30653	—	Kit, Mounting (Incls: 30613,30206,30284,43139)
270	30206	F	30206	F	30206	F	Pulley (10") [See Drive Packages, Tech Bulletin 003]
274	30234	STL	30234	STL	30234	STL	Hub, "H" M25 (Keyway M7) [See Drive Packages, Tech Bulletin 003]
275	30284	STL	30284	STL	30284	STL	Hub & Key Assy [See Drive Packages, Tech Bulletin 003]
283	34334	—	34334	—	34334	—	Kit, Oil Drain
295	6300	BBSS	6300	BBSS	6300	BBSS	Pump, Pulse (1 Qt.) 1000 PSI (See individual data sheet)
	6305	BBSS	6305	BBSS	6305	BBSS	Pump, Pulse (1 Gal.) 1000 PSI (See individual data sheet)
300	30220	NBR	30222	NBR	30224	NBR	Kit, Cup (Incls: 133,139,143,153) (355 for 820 & 1010)
301	30822	NBR	—	—	—	—	Kit, Bac-Cup (Incls: 133,139,143,355)
302	30219	NBR	30221	NBR	30223	NBR	Kit, Piston (Incls: 119,130,133,135-139,143,153 (355 for 820 & 1010))
	30843	NBR	—	—	—	—	Kit, Bac-Cup Piston (Incls: 119,133,139,143,153,355)
305	30397	NBR	30397	NBR	30397	NBR	Kit, Sleeve and Prrrrm-A-Lube Seal (Incls: 75,77,80,106,139)
	30227	NBR	30227	NBR	30227	NBR	Kit, Sleeve and Blue-Dot Seal (Incls: 75,77,80,101,106,139)
306	30305	NBR	30305	NBR	30305	NBR	Kit, Prrrrm-A-Lube Seal (Incls: 106,139)
	30226	NBR	30226	NBR	30226	NBR	Kit, Blue-Dot Seal (Incls: 101,106,139)
310	30687	NBR	30687	NBR	30687	NBR	Kit, Valve, Q.V. (Incls: 143,153,162-168)
	30449	NBR	30449	NBR	30449	NBR	Kit, Valve, F.V. (Incls: 143,153,162-168)
355	22130	NY	16981	NY	15770	NY	Insertor, Cup
352	44050	STZP	44050	STZP	44050	STZP	Tool, Oil Gauge Removal
360	25082	STZP	25082	STZP	25082	STZP	T-Wrench (M10)
	25083	STZP	25083	STZP	25083	STZP	T-Wrench (M17)
—	6107	—	6107	—	6107	—	Oil, Bottle (21 oz.) ISO 68 Multi-viscosity Hydraulic (Fill to specified crankcase capacity prior to start-up)

Bold print part numbers are unique to a particular pump model. Italics are optional items. [] Date of latest production change. R Components comply with RoHS Directive. See Tech Bulletins 001, 002, 003, 005, 016, 017, 020, 024, 026, 034, 036, 037, 038, 042, 074, 077 and 083 for additional information.

When replacing Prrrrm-A-Lube Seals with Blue-Dot Seals, wick must be installed.

MATERIAL CODES (Not Part of Part Number): ABS=ABS Plastic AL=Aluminum BB=Brass BBSP=Brass/Chrome Plated CM=Chrome-Moly F=Cast Iron FCM=Forged Chrome-moly FPM=Fluorocarbon NBR=Medium Nitrile (Buna-N) NY=Nylon POP=Polypropylene PTFE=Pure Polytetrafluoroethylene PVDF=Polyvinylidene Fluoride S=304SS SCP=304SS/Chrome Plated SNG=Special Blend (Buna) SS=316SS STL=Steel STCP=Steel/Chrome Plated STZP=Steel/Zinc Plated SZZ=304SS/Zamak TG=PTFE Graphite Compound (GIT) TNM=Special High Strength

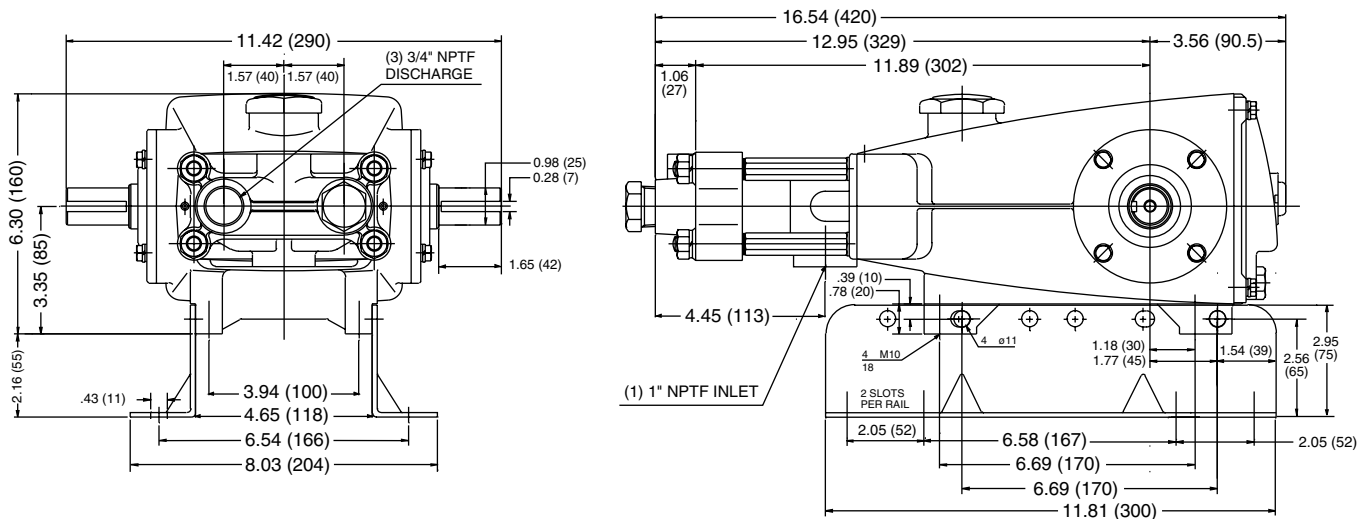

Models 623, 621, 625, 820, 821, 825, 1010, 1011, 1015

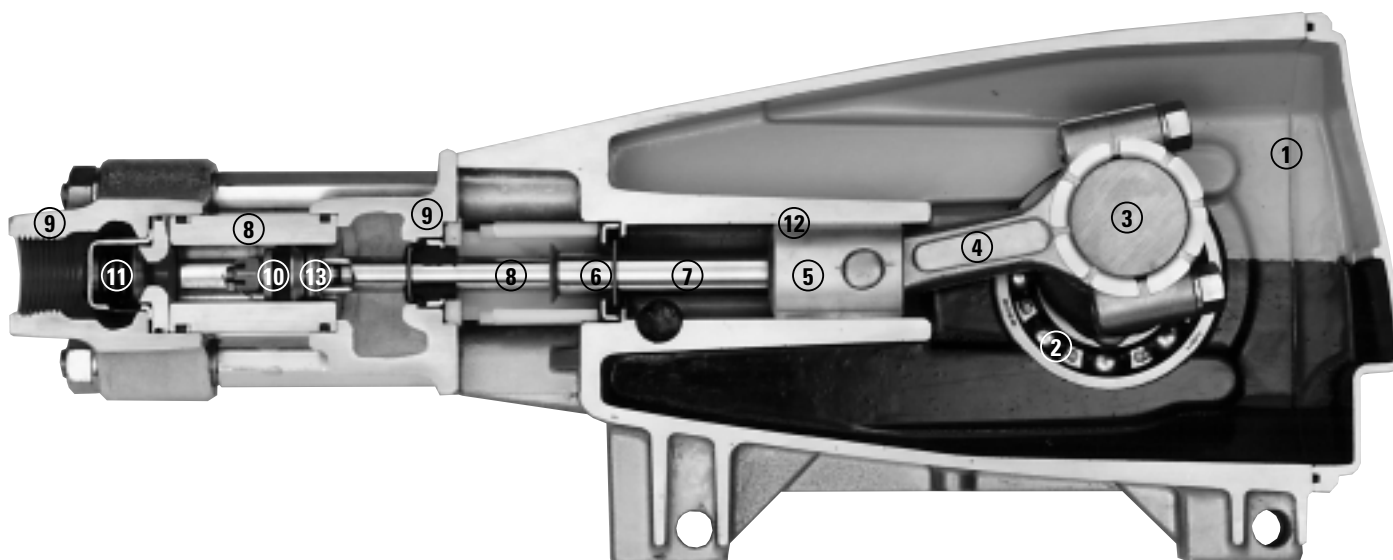

- 1 Die cast aluminum **crankcase** means high strength, lightweight, and excellent tolerance control.
- 2 Oversized crankshaft **bearings** provide extended bearing life and pump performance.
- 3 Chrome-moly **crankshaft** provides unmatched strength and surface hardness for long life.
- 4 Matched oversized TNM **connecting rods** for superior tensile strength and bearing quality.
- 5 The **piston rods** are high tensile strength stainless steel with Zamak crossheads.
- 6 The stainless steel **slinger** provides back-up protection for the crankcase seal, keeping pumped liquids out of the crankcase.
- 7 The **patented stepped piston rod** with hard chrome plated stainless steel **sleeve** provides a durable wear surface and easy wet-end servicing.
- 8 The **cylinder** and **sleeve** wear surfaces are hard chrome plated 304 stainless steel for longer service life.
- 9 **Manifolds** are of high tensile strength chrome plated brass or 316 stainless steel for special corrosion resistance.
- 10 100% wet **cup/seal** design adds to service life by allowing pumped liquids to cool and lubricate the elastomers on both sides.
- 11 304 stainless steel **valves, seats, and springs** provide corrosion-resistance, ultimate seating and extended life.
- 12 **Crossheads** are 360° supported for uncompromising alignment.
- 13 Mechanically actuated **inlet valves** provide strong lift and easy prime.

World Headquarters

CAT PUMPS

1681 - 94th Lane N.E. Minneapolis, MN 55449-4324

Phone (763) 780-5440 — FAX (763) 780-2958

e-mail: techsupport@catpumps.com

www.catpumps.com

International Inquiries

FAX (763) 785-4329

e-mail: intlsales@catpumps.com



The Pumps with Nine Lives

CAT PUMPS (U.K.) LTD.

1 Fleet Business Park, Sandy Lane, Church Crookham

FLEET, Hampshire, GU52 8BF, England

Phone Fleet 44 1252-622031 — Fax 44 1252-626655

e-mail: sales@catpumps.co.uk www.catpumps.co.uk

N.V. CAT PUMPS INTERNATIONAL S.A.

Heiveldkens 6A, B-2550 Kontich, Belgium

Phone 32-3-450.71.50 — Fax 32-3-450.71.51

e-mail: cpi@catpumps.be www.catpumps.be

CAT PUMPS DEUTSCHLAND GmbH

Buchwiese 2, D-65510 Idstein, Germany

Phone 49 6126-9303 0 — Fax 49 6126-9303 33

e-mail: catpumps@t-online.de www.catpumps.de