

Model 6775 Shown  
(Shaft protection and rails sold with pump)

## 60 Frame Plunger Pump

**Standard Brass  
Model**

**6775**

**Stainless Steel  
Model**

**6771**

**Nickel Aluminum  
Bronze Model**

**6777**

### FEATURES

- Triplex plunger design delivers high efficiency and low pulsation.
- Durable dual V-Packings are lubricated and cooled by pumped liquid.
- Pre-set Lo-Pressure Seals provide secondary protection against external leaks and require no packing adjustment.
- Special high-density, polished, concentric plungers provide a true wear surface and extended seal life.
- Specially formulated Seals and V-Packings offer unmatched performance and extended life.
- Guided valve design for extended valve life.
- Wet-end easily serviced without entering crankcase.

### SPECIFICATIONS

	U.S. Measure	Metric Measure
Flow .....	75 gpm	(284 l/m)
Pressure Range .....	100 to 1200 psi	(7 to 85 bar)
Inlet Pressure Range .....	Flooded to 50 psi	(Flooded to 3.5 bar)
RPM.....	650 rpm	(650 rpm)
Bore .....	2.165"	(55 mm)
Stroke .....	2.579"	(65.5 mm)
Crankcase Capacity .....	10 Qts.	(9.46 l)
Max. Liquid Temperature .....	140°F	(60°C)
Above 130°F call CAT PUMPS for inlet conditions and elastomer recommendations.		
Inlet Ports (2) .....	2" NPTF	(2" NPTF)
Discharge Ports (2) .....	1-1/4" NPTF	(1-1/4" NPTF)
Shaft Diameter.....	1.772"	(45 mm)
Weight		
6775 .....	356 lbs.	(161 kg)
6771 .....	353 lbs.	(160 kg)
6777 .....	327 lbs.	(148 kg)
Dimensions		
6775, 6777.....	31.14 x 24.37 x 12.87"	(791 x 619 x 327 mm)
6771.....	30.71 x 24.37 x 12.44"	(780 x 619 x 316 mm)

### ELECTRIC HORSEPOWER REQUIREMENTS

FLOW		PRESSURE			RPM
		psi 900	psi 1000	psi 1200	
U.S. gpm	l/m	bar 60	bar 70	bar 85	
75	284	46.2	51.4	61.6	650
70	265	43.2	47.9	57.5	607
60	227	37.0	41.1	49.3	520
50	189	30.8	34.2	41.1	433

<b>DETERMINING THE PUMP rpm</b>	$\frac{\text{Rated gpm}}{\text{Rated rpm}}$	=	$\frac{\text{"Desired" gpm}}{\text{"Desired" rpm}}$
<b>DETERMINING THE REQUIRED H.P.</b>	$\frac{\text{gpm} \times \text{psi}}{1460}$	=	Electric Brake H. P. Required
<b>DETERMINING MOTOR PULLEY SIZE</b>	$\frac{\text{Motor Pulley O.D.}}{\text{Pump rpm}}$	=	$\frac{\text{Pump Pulley O.D.}}{\text{Motor rpm}}$

See complete Drive Packages [Includes: Pulleys, Belts, Hubs, Key] Tech Bulletin 003.  
Refer to pump Service Manual for repair procedure and additional technical information.

#### ⚠ CAUTIONS AND WARNINGS

All High Pressure Systems require a primary pressure regulating device (i.e. regulator, unloader) and a secondary pressure relief device (i.e. pop-off valve, relief valve). Failure to install such relief devices could result in personal injury or damage to pump or property. CAT PUMPS does not assume any liability or responsibility for the operation of a customer's high pressure system.

Read all CAUTIONS and WARNINGS before commencing service or operation of any high pressure system. The CAUTIONS and WARNINGS are included in each service manual and with each Data sheet. CAUTIONS and WARNINGS can also be viewed online at [www.catpumps.com/cautions-warnings](http://www.catpumps.com/cautions-warnings) or can be requested directly from CAT PUMPS.

#### WARRANTY

View the Limited Warranty on-line at [www.catpumps.com/warranty](http://www.catpumps.com/warranty).

*"Customer confidence is our greatest asset"*

# PARTS LIST

ITEM	PART NUMBER						DESCRIPTION	QTY
	6775	MATL	6771	MATL	6777	MATL		
2	43048	STL	43048	STL	43048	STL	Key (M14x9x90)	1
5	<b>126532</b>	<b>STCP R</b>	<b>89728</b>	<b>S</b>	<b>89728</b>	<b>S</b>	Screw, HH (M10 x 40)	8
6	<b>126231</b>	<b>STCP R</b>	<b>15847</b>	<b>S</b>	<b>15847</b>	<b>S</b>	Lockwasher (M10)	8
7	<b>126574</b>	<b>STZP R</b>	<b>19934</b>	<b>S</b>	<b>19934</b>	<b>S</b>	Washer, Flat (M10)	8
8	29443	AL	29443	AL	29443	AL	Cover, Bearing, Outer	2
10	29444	NBR	29444	NBR	29444	NBR	O-Ring Outer, Bearing Cover - 70D	2
11	11443	NBR	11443	NBR	11443	NBR	Seal, Oil, Crankshaft - 70D	2
12	43642	STZP R	43642	STZP R	43642	STZP R	Washer, Shim (M120 x 0.3)	0-2
	126594	STCP R	126594	STCP R	126594	STCP R	Washer, Shim (M120 x 0.3)	0-2
13	126595	STCP R	126595	STCP R	126595	STCP R	Washer, Shim (M120 x 0.5)	0-2
15	29441	STL	29441	STL	29441	STL	Bearing, Roller	2
16	29442	STL	29442	STL	29442	STL	Cover, Bearing, Inner	2
17	29444	NBR	29444	NBR	29444	NBR	O-Ring Inner, Bearing Cover - 70D	2
20	126612	BBHS	126612	BBHS	126612	BBHS	Rod, Connecting (Includes: 21, 22)	3
21	126560	STCP R	126560	STCP R	126560	STCP R	Washer, Locking	3
22	126593	STCP R	126593	STCP R	126593	STCP R	Washer, Shim (M10.5 x 1.5)	6
25	29440	FCM	29440	FCM	29440	FCM	Crankshaft, Dual End	1
31	<b>828710</b>	<b>PE</b>	<b>828710</b>	<b>PE</b>	<b>828710</b>	<b>PE</b>	Protector, Oil Cap w/Foam Gasket	1
32	43211	ABS	43211	ABS	43211	ABS	Cap, Oil Filler	1
33	14177	NBR	14177	NBR	14177	NBR	O-Ring, Oil Filler Cap - 70D	1
34	126743	STCP R	126743	STCP R	126743	STCP R	Bolt, Eye (M12) (For Lifting Pump Only)	1
38	129313	RBR	129313	RBR	129313	RBR	Gasket, Flat	1
39	27769	ABS	27769	ABS	27769	ABS	Stick, Dip	1
40	<b>126531</b>	<b>STCP R</b>	<b>89627</b>	<b>S</b>	<b>89627</b>	<b>S</b>	Screw, HH (M10 x 30)	8
41	<b>126231</b>	<b>STZP R</b>	<b>15847</b>	<b>S</b>	<b>15847</b>	<b>S</b>	Lockwasher (M10)	8
42	<b>126574</b>	<b>STCP R</b>	<b>19934</b>	<b>S</b>	<b>19934</b>	<b>S</b>	Washer, Flat (M10)	8
48	25625	STCP	25625	STCP	25625	STCP	Plug, Drain (1/4 x 19BSP)	1
49	23170	NBR	23170	NBR	23170	NBR	O-Ring, Drain Plug - 70D	1
50	29438	AL	29438	AL	29438	AL	Cover, Rear	1
51	129386	NBR	129386	NBR	129386	NBR	Gasket, Rear Cover	1
53	45303	AL	45303	AL	45303	AL	Crankcase w/Guide Pins (Includes: 34, 54)	1
54	43282	S	43282	S	43282	S	Pin, Guide	2
55	<b>126553</b>	<b>STCP R</b>	<b>89615</b>	<b>S</b>	<b>89615</b>	<b>S</b>	Stud (M16 x 70)	2
64	29481	CM	29481	CM	29481	CM	Pin, Crosshead	3
65	† 45384	SSZZ	45384	SSZZ	45384	SSZZ	Rod, Plunger	3
69	126588	STCP R	126588	STCP R	126588	STCP R	Washer, Oil Seal	3
70	29454	NBR	29454	NBR	29454	NBR	Seal, Oil - 80D	3
75	44752	NBR	44752	NBR	44752	NBR	Slinger, Barrier - 85D	3
88	45677	SS	45677	SS	45677	SS	Washers, Keyhole (M14)	3
90	44749	CC	44749	CC	44749	CC	Plunger (M55 x 185)	3
95	<b>89783</b>	<b>S</b>	<b>44748</b>	<b>SS</b>	<b>44748</b>	<b>SS</b>	Stud, Plunger Retainer (M14 x 147)	3
96	20214	PTFE	20214	PTFE	20214	PTFE	Back-up-Ring, Plunger Retainer	3
97	17616	NBR	17616	NBR	17616	NBR	O-Ring, Plunger Retainer - 80D	3
	11686	FPM	11686	FPM	11686	FPM	O-Ring, Plunger Retainer - 80D	3
	◆ 703369	EPDM	◆ 703369	EPDM	◆ 703369	EPDM	O-Ring, Plunger Retainer - 70D	3
99	<b>45276</b>	<b>S</b>	<b>44750</b>	<b>SS</b>	<b>44750</b>	<b>SS</b>	Retainer, Plunger (M14)	3
100	855000	PVDF	855000	PVDF	855000	PVDF	Retainer, Seal, 2-pc (See Tech Bulletin 105)	3
101	44762	—	44762	—	44762	—	Wick, Long Tab (M55 x 185)	3
106	44757	NBR	44757	NBR	44757	NBR	Seal, LPS w/SS-Spg	3
	45882	FPM	45882	FPM	45882	FPM	Seal, LPS w/SS-Spg	3
	702228	SFTB	702228	SFTB	702228	SFTB	Seal, LPS w/SS-Spg	3
110	<b>49457</b>	<b>NABC</b>	<b>45769</b>	<b>SS</b>	<b>44754</b>	<b>NAB</b>	Manifold, Inlet	1
112	18175	NBR	18175	NBR	18175	NBR	O-Ring, Spacer, Inner - 80D	3
	13266	FPM	13266	FPM	13266	FPM	O-Ring, Spacer, Inner - 70D	3
	◆ 702442	EPDM	◆ 702442	EPDM	◆ 702442	EPDM	O-Ring, Spacer, Inner - 75D	3
114	44767	SS	44767	SS	44767	SS	Spacer, Inlet Manifold	3
115	18175	NBR	18175	NBR	18175	NBR	O-Ring, Spacer, Outer - 80D	3
	13266	FPM	13266	FPM	13266	FPM	O-Ring, Spacer, Outer - 70D	3
	◆ 702442	EPDM	◆ 702442	EPDM	◆ 702442	EPDM	O-Ring, Spacer, Outer - 75D	3
116	<b>126569</b>	<b>STCP R</b>	<b>19086</b>	<b>S</b>	<b>19086</b>	<b>S</b>	Lockwasher (M16)	4
117	<b>126537</b>	<b>STCP R</b>	<b>89729</b>	<b>S</b>	<b>89729</b>	<b>S</b>	Screw, HH (M16 x 55)	4
126	48392	D	48392	D	48392	D	Adapter, Female (See Tech Bulletin 087)	3
	45771	SS	45771	SS	45771	SS	Adapter, Female	3
127	44764	STG*	44764	STG*	44764	STG*	V-Packing	6
128	45772	SS	45772	SS	45772	SS	Adapter, Male	3
141	44943	SS	44943	SS	44943	SS	Coil Spring, Spacer	24
142	<b>48501</b>	<b>BB</b>	<b>45383</b>	<b>SS</b>	<b>45383</b>	<b>SS</b>	Spacer w/Coil Springs	3
155	18178	NBR	18178	NBR	18178	NBR	O-Ring, Spacer - 80D	3
	13338	FPM	13338	FPM	13338	FPM	O-Ring, Spacer - 70D	3
	◆ 701657	EPDM	◆ 701657	EPDM	◆ 701657	EPDM	O-Ring, Spacer - 70D	3
157	45321	SS	45321	SS	45321	SS	Spacer, V-Packing	3
159	18178	NBR	18178	NBR	18178	NBR	O-Ring, Spacer - 80D	3
	13338	FPM	13338	FPM	13338	FPM	O-Ring, Spacer - 70D	3
	◆ 701657	EPDM	◆ 701657	EPDM	◆ 701657	EPDM	O-Ring, Spacer - 70D	3
160	44756	S	44756	S	44756	S	Pin, Guide	2
163	18176	NBR	18176	NBR	18176	NBR	O-Ring, Seat - 80D	6
	13278	FPM	13278	FPM	13278	FPM	O-Ring, Seat	6
	◆ 702445	EPDM	◆ 702445	EPDM	◆ 702445	EPDM	O-Ring, Seat - 70D	6
164	† 44772	SS	44772	SS	44772	SS	Seat	6
165	76304	SS	76304	SS	76304	SS	Guide, Spring	6
166	76319	SS	76319	SS	76319	SS	Valve, Guided, QV	6
167	76309	SS	76309	SS	76309	SS	Spring	6
168	76349	PVDF	76349	PVDF	76349	PVDF	Retainer, Spring	6
169	76306	SS	76306	SS	76306	SS	Retainer, Bushing	6
170	† 44776	SS	44776	SS	44776	SS	Washer, Retainer	6
171	44780	SS	44780	SS	44780	SS	Spring, Coil, Valve Plug	6
172	18177	NBR	18177	NBR	18177	NBR	O-Ring, Valve Plug - 80D	6
	13279	FPM	13279	FPM	13279	FPM	O-Ring, Valve Plug - 70D	6
	◆ 701988	EPDM	◆ 701988	EPDM	◆ 701988	EPDM	O-Ring, Valve Plug	6
174	<b>49461</b>	<b>NABC</b>	<b>48572</b>	<b>SS</b>	<b>44778</b>	<b>NAB</b>	Plug, Valve [3/00]	1
175	—	—	<b>48573</b>	<b>S</b>	—	—	Screw, HSH (M16x35) [3/00]	24
185	<b>49459</b>	<b>NABC</b>	<b>48489</b>	<b>SS</b>	<b>44769</b>	<b>NAB</b>	Manifold, Discharge [3/00]	1
186	<b>126569</b>	<b>STCP R</b>	<b>19086</b>	<b>S</b>	<b>19086</b>	<b>S</b>	Lockwasher (M16)	2
188	<b>126744</b>	<b>STCP R</b>	<b>89694</b>	<b>S</b>	<b>89694</b>	<b>S</b>	Screw, HSH (M16 x 110)	8
194	<b>126525</b>	<b>STCP R</b>	<b>81291</b>	<b>S</b>	<b>81291</b>	<b>S</b>	Nut, Hex (M16)	2
250	29445	AL	29445	AL	29445	AL	Protector, Shaft	1
255	33243	STZP	33243	STZP	33243	STZP	Kit, Mount (Included w/Pump)	1

# EXPLODED VIEW

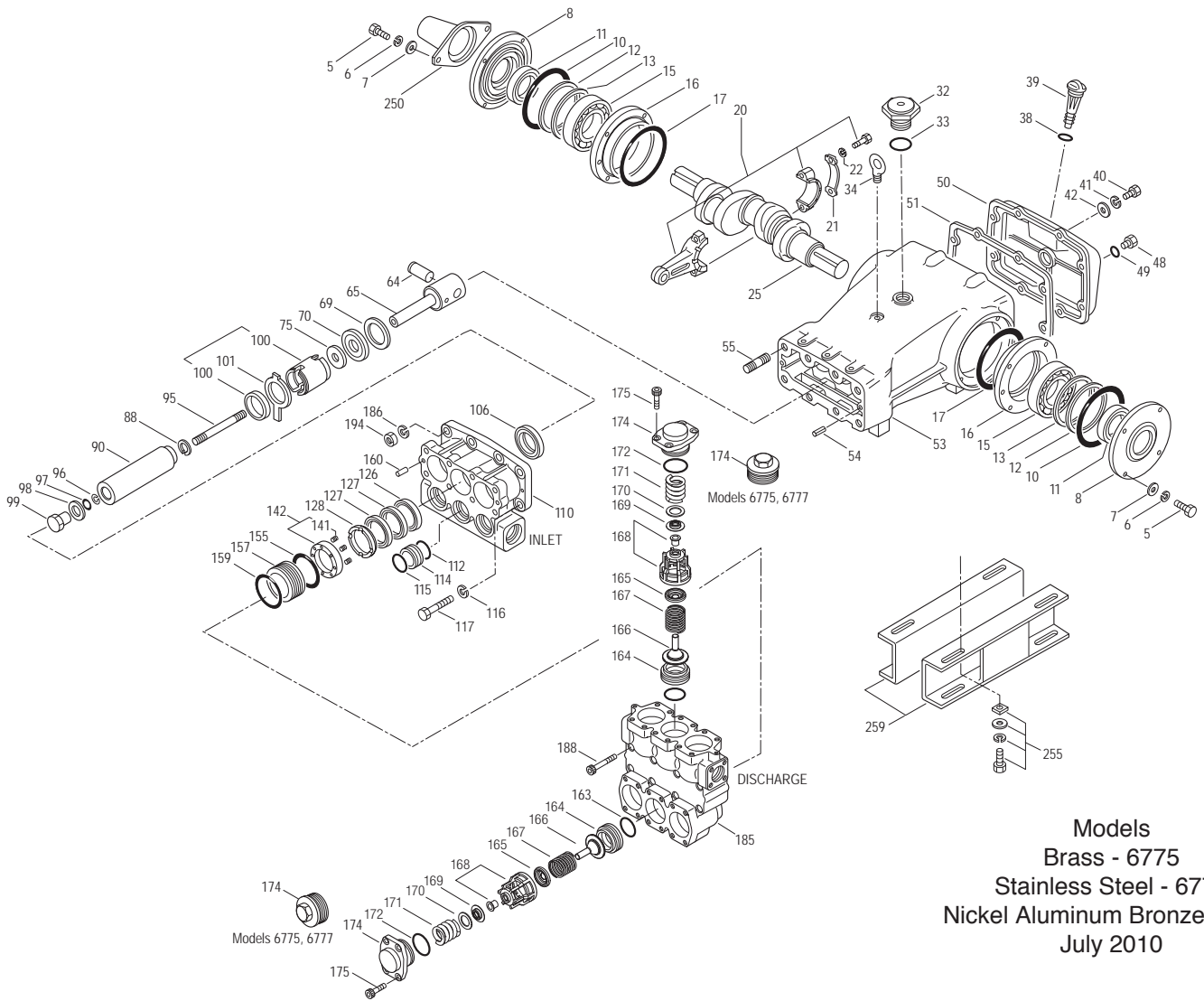

Models  
 Brass - 6775  
 Stainless Steel - 6771  
 Nickel Aluminum Bronze - 6777  
 July 2010

ITEM	PART NUMBER				DESCRIPTION	QTY		
	6775	MATL	6771	MATL			6777	MATL
259	29477	STZP	29477	STZP	29477	STZP	Rail (Included w/Pump) (Two per pump required)	2
275	990014	STL	990014	STL	990014	STL	Hub, 45mm (M14x9 Keyway) [See Drive Packages, Tech Bulletin 003] (not shown)	1
279	30429	STZP	30429	STZP	30429	STZP	Oiler (10 oz.) (Not Shown)	3
281	30969	—	30969	—	30969	—	Oiler, Glass (10 oz.) (Not Shown)	3
282	10070	NBR	10070	NBR	10070	NBR	Gasket, Oiler (Not Shown)	3
283	34314	—	34314	—	34314	—	Kit, Oil Drain (3/8" x 48")	1
290	6124	—	6124	—	6124	—	Gasket, Liquid (3.0 oz.)	1
299	<b>996760</b>	<b>BBCP</b>	<b>996667</b>	<b>SS</b>	<b>994820</b>	<b>NAB</b>	Head, Complete	1
300	34091	NBR*	34091	NBR*	34091	NBR*	Kit, Seal (Includes: 97,106,112,115,127,155,159)	1
	34093	FPM*	34093	FPM*	34093	FPM*	Kit, Seal (Includes: 97,106,112,115,127,155,159)	1
	♦ 76091	EPDM	♦ 76091	EPDM	♦ 76091	EPDM	Kit, Seal (Includes: 97,106,112,115,127,155,159)	1
310	76140	NBR	76140	NBR	76140	NBR	Kit, Valve (Includes: 163,164,165,166,167,168,169,170,172)	2
	76145	FPM	76145	FPM	76145	FPM	Kit, Valve (Includes: 163,164,165,166,167,168,169,170,172)	2
	♦ 76240	EPDM	♦ 76240	EPDM	♦ 76240	EPDM	Kit, Valve (Includes: 163,164,165,166,167,168,169,170,172)	2
—	819010	F	819010	F	819010	F	Assy, Crankcase, Cast Iron Conversion	1
—	88902	STZP	88902	STZP	88902	STZP	Stud (M16x277) (For removing D.M., I.M.) (not shown)	2
390	^ 717500	SS	^ 717500	SS	^ 717500	SS	C.A.T. (Inlet pressure stabilizer for RO and boosted inlet applications) (not shown)	1
391	^ 717508	SS	^ 717508	SS	^ 717508	SS	Adapters (2 per C.A.T.) (See Data Sheet for complete selection) (not shown)	2
392	^ 701833	SS	^ 701833	SS	^ 701833	SS	Elbow Assy used with Adapter Assy 717508 (not shown)	1
—	6575	—	6575	—	6575	—	Plunger Pump Service DVD	1
—	6105	—	6105	—	6105	—	Oil, Twin Pack (Two 2.5 Gal) ISO-68 Hydraulic (Fill to specified crankcase capacity prior to start-up)	1
—	—	—	6119	—	—	—	Lubricant, Antiseize (1 oz.) (See Tech Bulletin 095)	1

**Bold print part numbers are unique to a particular pump model.**  
*Italics are optional items.*

- [ ] Date of latest production change.
- † Production parts different from replacement parts.
- R Components comply with RoHS Directive.
- \* Review material codes for individual items (STG generally may be used as alternate).
- ^ **C.A.T. highly recommended for pressurized inlet, R.O. and Industrial applications.**

♦ Silicone oil/grease required

View Tech Bulletins 003, 024, 036, 043, 052, 053, 054, 064, 074, 077, 083, 084, 087, 095 and 105 for additional information.

MATERIAL CODES (Not Part of Part Number): ABS=ABS Plastic AL=Aluminum  
 BB=Brass BBPC=Brass/Chrome Plated BBHS=Brass/High Strength  
 CC=Ceramic CM=Chrome-Moly D=Acetal F=Cast Iron FCM=Forged Chrome-moly  
 FPM=Fluorocarbon NAB=Nickel Aluminum Bronze NABC=Nickel Aluminum Bronze Chrome Plated  
 NBR=Medium Nitrile PE=Polyethylene (Buna-N) PTFE=Pure Polytetrafluoroethylene  
 PVDF=Polyvinylidene Fluoride S=304SS SS=316SS SSZZ=316SS/Zamak  
 STCP=Steel/Chrome Plated STG=Special Blend PTFE White STL=Steel STZP=Steel/Zinc Plated

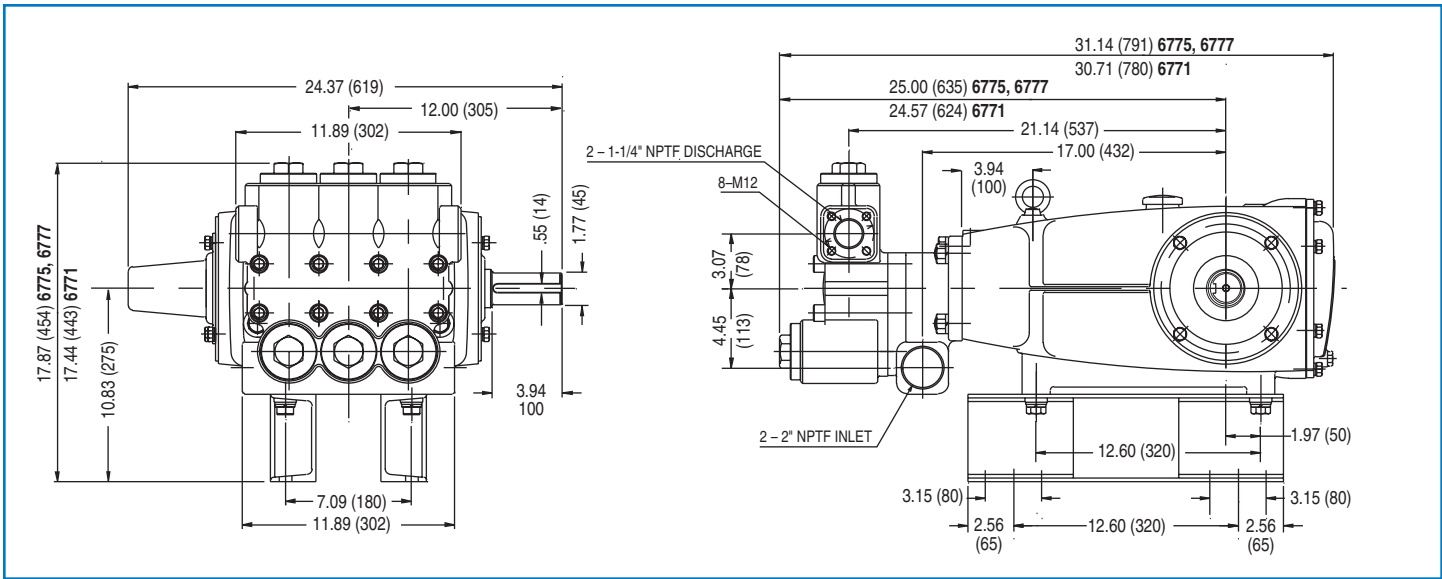

Models 6771, 6775, 6777

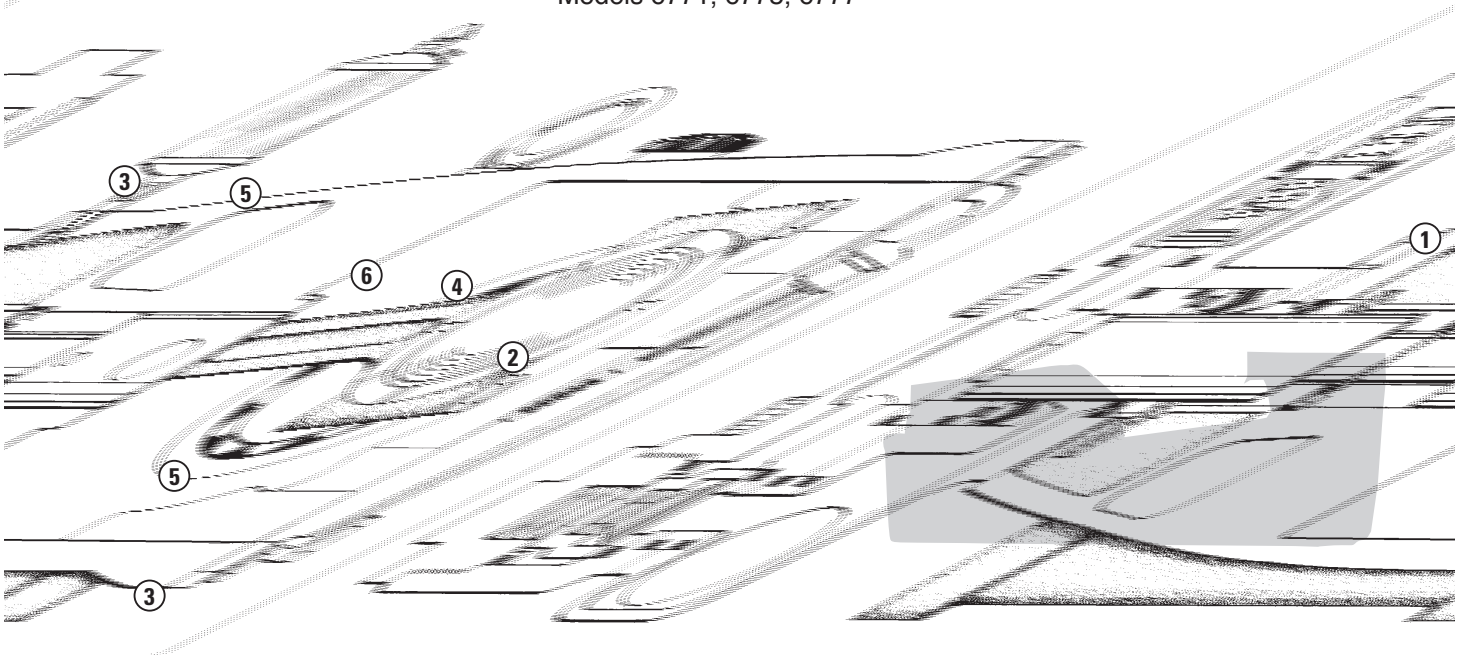

- 1 Dipstick offers convenient top access for easy observation check.
- 2 Special concentric, high-density, polished, sintered ceramic plungers provide a true wear surface and extend seal life.
- 3 Manifolds are a high tensile strength brass, 316 stainless steel or nickel aluminum bronze for long term, continuous duty.
- 4 100% wet seal design adds to service life by allowing pumped liquids to cool and lubricate on both sides.
- 5 Stainless steel valves, seats and springs provide corrosion-resistance, ultimate seating and extended life.
- 6 Specialty formulated, CAT PUMP exclusive, V-Packings offer unmatched performance and seal life.

**World Headquarters**

**CAT PUMPS**

1681 - 94th Lane N.E. Minneapolis, MN 55449 - 4324

Phone (763) 780-5440 — FAX (763) 780-2958

e-mail: techsupport@catpumps.com

www.catpumps.com

**International Inquiries**

**FAX (763) 785-4329**

e-mail: intlsales@catpumps.com



*The Pumps with Nine Lives*

**CAT PUMPS (U.K.) LTD.**

1 Fleet Business Park, Sandy Lane, Church Crookham

FLEET, Hampshire GU52 8BF, England

Phone Fleet 44 1252-622031 — Fax 44 1252-626655

e-mail: sales@catpumps.co.uk www.catpumps.co.uk

**N.V. CAT PUMPS INTERNATIONAL S.A.**

Heiveldkens 6A, 2550 Kontich, Belgium

Phone 32-3-450.71.50 — Fax 32-3-450.71.51

e-mail: cpi@catpumps.be www.catpumps.be

**CAT PUMPS DEUTSCHLAND GmbH**

Buchwiese 2, D-65510 Idstein, Germany

Phone 49 6126-9303 0 — Fax 49 6126-9303 33

e-mail: catpumps@t-online.de www.catpumps.de