



7 Frame Plunger Pump

Model 70
Gearbox Models 70G1
70G118

FEATURES

Superior Design

- Triplex plunger design gives smoother liquid flow.
- Lo-Pressure Seals and V-Packings are completely lubricated and cooled by the liquid being pumped.
- Inlet and discharge valve assemblies interchange for easier maintenance.
- Lubricated Lo-Pressure Seal provides double protection against external leakage.
- Oil bath crankcase assures optimum lubrication.
- Close tolerance concentricity of the ceramic plunger maximizes seal life.
- Optional Gearbox Pump version for direct mounting to gas engine.

Quality Materials

- Precision design 304 stainless steel valves and seats are hardened and polished for ultimate seating and extended valve life.
- Forged brass manifold is strong and corrosion resistant.
- Special concentric, high-density, polished, solid ceramic plungers provide a true wear surface and extended seal life.
- Specially formulated, CAT PUMP exclusive, V-Packing offers unmatched performance and seal life.
- Die cast aluminum crankcase provides high strength, minimum weight and precision tolerance control.
- Chrome-moly crankshaft gives unmatched strength and surface hardness.
- Oversized crankshaft bearings mean longer bearing life.

Easy Maintenance

- Wet-end is easily serviced without entering crankcase, requiring less time and effort.
- Valve assemblies are accessible without disturbing piping, for quick service.
- Preset packings mean no packing gland adjustment is necessary, reducing maintenance costs.

⚠ WARNING

All systems require both a primary pressure regulating device (i.e., regulator, unloader) and a secondary pressure safety relief device (i.e., pop-off valve, safety valve). Failure to install such relief devices could result in personal injury or damage to the pump or to system components. CAT PUMPS does not assume any liability or responsibility for the operation of a customer's high pressure system.

SPECIFICATIONS

U.S. Measure

Metric Measure

MODELS 70, 70G, 70G118

Flow	4.5 GPM	(17 L/M)
Pressure Range.....	100 to 5000 PSI	(7 to 345 BAR)
Inlet Pressure Range.....	Flooded to 60 PSI	(Flooded to 4 BAR)
RPM	1700 RPM	(1700 RPM)
Engine RPM (70G1, 70G118)	3465 RPM	(3465 RPM)
Bore.....	0.551"	(14 mm)
Stroke.....	0.945"	(24 mm)
Crankcase Capacity	25 oz.	(0.75 L)
Maximum Liquid Temperature.....	160°F	(71°C)
Above 130°F call CAT PUMPS for inlet conditions and elastomer recommendations.		
Inlet Ports (2)	1/2" NPTF	(1/2" NPTF)
Discharge Ports (2).....	3/8" NPTF	(3/8" NPTF)
Shaft Diameter - Single End.....	0.945"	(24 mm)
Weight w/o Gearbox	36.2 lbs.	(16.4 kg)
Dimensions.....	14.21 x 9.21 x 6.69"	(361 x 234 x 170 mm)
Dimensions w/Gearbox	14.21 x 10.75 x 8.19"	(361 x 273 x 208 mm)

See Gearbox Data Sheet for additional information.

ELECTRIC HORSEPOWER REQUIREMENTS

FLOW		PRESSURE				MOTOR PULLEY SIZE Using 1725 RPM Motor & Std. Pump Pulley O.D.	
		PSI 3000	PSI 3500	PSI 4000	PSI 5000		
U.S. GPM	L/M	BAR 210	BAR 245	BAR 275	BAR 345	RPM	Pulley O.D.
4.0	15	8.2	9.6	11.0	13.7	1511	8.5
4.5	17	9.3	10.8	12.3	15.4	1700	9.5
4.5	17	9.3	10.8	12.3	15.4	1700	Gearbox

**DETERMINING
THE PUMP R.P.M.**

$\frac{\text{Rated G.P.M.}}{\text{Rated R.P.M.}}$

= $\frac{\text{"Desired" G.P.M.}}{\text{"Desired" R.P.M.}}$

**DETERMINING
THE REQUIRED H.P.**

$\frac{\text{GPM} \times \text{PSI}}{1460}$

= Electric Brake
H. P. Required

**DETERMINING
MOTOR PULLEY SIZE**

$\frac{\text{Motor Pulley O.D.}}{\text{Pump R.P.M.}}$

= $\frac{\text{Pump Pulley O.D.}}{\text{Motor R.P.M.}}$

See complete Drive Packages [Includes: Pulleys, Belts, Hubs, Key] Tech Bulletin 003.
Refer to pump **Service Manual** for repair procedure, additional technical information and **pump warranty**.

"Customer confidence is our greatest asset"

PARTS LIST

ITEM	P/N	MATL	DESCRIPTION	QTY
2	30067	STL	Key (M8x7.5x25)	1
5	92519	STZP	Screw, HHC Sems (M6x16)	8
	125824	STCP R	Screw, HHC Sems (M6x16)	8
8	43466	AL	Cover, Bearing	1
9	815280	FBR	Shim, Split, 2 Pc.	1
10	12393	NBR	O-Ring, Bearing Cover	2
11	43222	NBR	Seal, Oil, Crankshaft - 70D	1
15	43221	STL	Bearing, Roller	2
20	48863	TNM	Rod, Connecting [6/02]	3
25	119234	FCM	Crankshaft, Single End	1
	46554	FCM	Crankshaft, Single End (Gearbox Only)	1
30	44967	AL	Cover, Blind Bearing	1
31	828710	—	Protector, Oil Cap w/Foam Gasket	1
32	44666	RTP	Cap, Oil Filler, Domed	1
33	14177	NBR	O-Ring, Oil Filler Cap - 70D	1
37	92241	—	Gauge, Oil, Bubble w/Gasket - 80D	1
38	44428	NBR	Gasket, Flat, Oil Gauge - 80D	1
40	92520	STZP	Screw, HHC Sems (M6x20)	4
	126541	STCP R	Screw, HHC Sems (M6x20)	4
48	25625	STCP	Plug, Drain (1/4"x19BSP)	1
49	23170	NBR	O-Ring, Drain Plug - 70D	1
50	46509	AL	Cover, Rear	1
51	44836	NBR	O-Ring, Rear Cover - 70D	1
53	45361	AL	Crankcase w/Guide Pins	1
56	44983	POP	Pan, Oil	1
64	43237	CM	Pin, Crosshead	3
65	48913	SHS	Rod, Plunger, Short [5/02]	3
69	126589	STCP R	Washer, Oil Seal	3
70	43228	NBR	Seal, Oil, Crankcase	3
75	43328	S	Slinger, Barrier	3
88	45697	S	Washer, Keyhole (M18)	3
89	46556	BB	Spacer	3
90	45890	CC	Plunger (M14x72)	3
95	89649	STZP	Stud, Plunger Retainer (M6x70)	3
	126559	STCP R	Stud, Plunger Retainer (M6x70)	3
96	43235	PTFE	Back-up-Ring, Plunger Retainer	3
97	17399	NBR	O-Ring, Plunger Retainer - 80D	3
	14160	FPM	O-Ring, Plunger Retainer - 70D	3
98	45891	CU	Gasket, Plunger Retainer	3
99	46504	S	Retainer, Plunger (M6)	3
100	45689	PVDF	Retainer, Seal, 2-Pc	3
101	43571	—	Wick, Long Tab	3
106	45188	NBR	Seal, LPS w/S-Spg	3
	701790	SFTA	Seal, LPS w/SS-Spg	3
120	46566	BB	Case, Seal	3
121	20285	NBR	O-Ring, Seal Case - 70D	3
	11693	FPM	O-Ring, Seal Case	3
126	45896	BB	Adapter, Female	3
127	45895	SNG	V-Packing	9
	701911	SFTA	V-Packing	9
	48300	STG	V-Packing	9
128	46567	BB	Adapter, Male	3
139	43448	BB	Plug, Inlet Manifold (1/2" NPTM)	1
162	20937	PTFE	Back-up-Ring, Spiral, Seat	6
163	17547	NBR	O-Ring, Seat - 85D	6
	11685	FPM	O-Ring, Seat - 85D	6
164	46560	S	Seat	6
166	46562	S	Valve	6
167	43750	S	Spring	6
168	44565	PVDF	Retainer, Spring	6
172	145952	NBR	O-Ring, Valve Plug -70D	6
	31932	FPM	O-Ring, Valve Plug -75D	6
173	46692	PTFE	Back-up-Ring, Spiral, Valve Plug	6
174	46581	BB	Plug, Valve, Extended	6
185	46558	FBB	Head, Manifold (M10)	1
187	46868	S	Stud, Manifold (M10x35)	4
194	45550	STZP	Nut, Flanged (M10)	4
	126567	STCP R	Nut, Flanged (M10)	4
255	30243	STZP	Kit, Direct Mount	1
260	30645	STZP	Assy, Angle Rail A	1
	30611	STZP	Assy, Angle Rail B	1
265	30660	—	Kit, Complete Mounting - U.S. (Incls: 30645, 33000, 30206, 43256, 30067)	1
269	30206	F	Pulley (10") AB [See Drive Packages Tech Bulletin 003]	1
274	33000	STL	Hub (M24), H Series [See Drive Packages Tech Bulletin 003]	1

EXPLODED VIEW

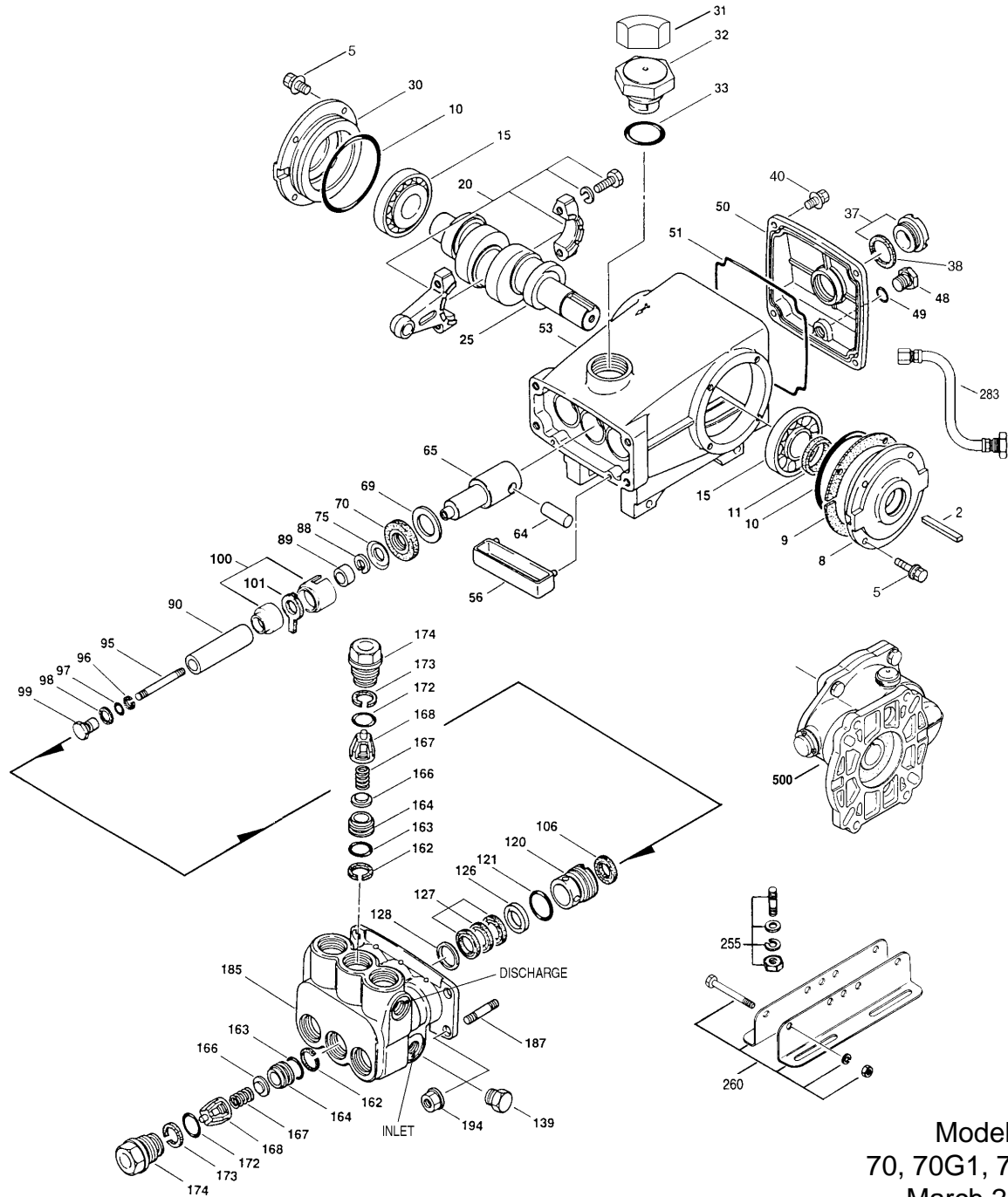

Models
70, 70G1, 70G118
March 2007

ITEM	P/N	MATL	DESCRIPTION	QTY
283	34334	—	Kit, Oil Drain	1
299	814840	FBB	Head, Complete	1
300	33799	NBR	Kit, Seal (Incls: 97,101,106,121,127)	1
	31799	FPM	Kit, Seal (Incls: 97,101,106,121,127)	1
310	33822	NBR	Kit, Valve (Incls: 162,163,164,166,167,168,172,173)	2
	31722	FPM	Kit, Valve (Incls: 162,163,164,166,167,168,172,173)	2
350	30696	STZP	Pliers, Reverse	1
351	43257	STZP	Tool, Seal Case Removal	1
352	44050	STZP	Tool, Oil Gauge Removal	1
500	8071	—	Gearbox, 1" (See 8051-8078 Data Sheet)	1
	8078	—	Gearbox, 1-1/8" (See 8051-8078 Data Sheet)	1
—	6107	—	Oil, Bottle (21 oz.) ISO 68 Multi-viscosity Hydraulic (Fill to specified crankcase capacity prior to start-up)	1

Italics are optional items. [] Date of latest production change. R Components comply with RoHS Directive.

Refer to Tech Bulletins 002, 003, 024, 036, 043, 051, 054, 061, 064, 067, 074, 077 and 083 for additional information.

MATERIAL CODES (Not Part of Part Number): AL=Aluminum BB=Brass CC=Ceramic CM=Chrome-Moly CU=Copper F=Cast Iron FBB=Forged Brass FBR=Fiber
FCM=Forged Chrome-moly FPM=Fluorocarbon HS=High Strength NBR=Medium Nitrile (Buna-N) POP=Polypropylene PTFE=Pure Polytetrafluoroethylene
PVDF=Polyvinylidene Fluoride RTP=Reinforced Composite S=304SS SFTA=Special Blend PTFE Tan SHS=304SS/High Strength SNG=Special Blend (Buna)
STG=Special Blend PTFE White STL=Steel STCP=Steel/Chrome Plated STZP=Steel/Zinc Plated TNM=Special High Strength

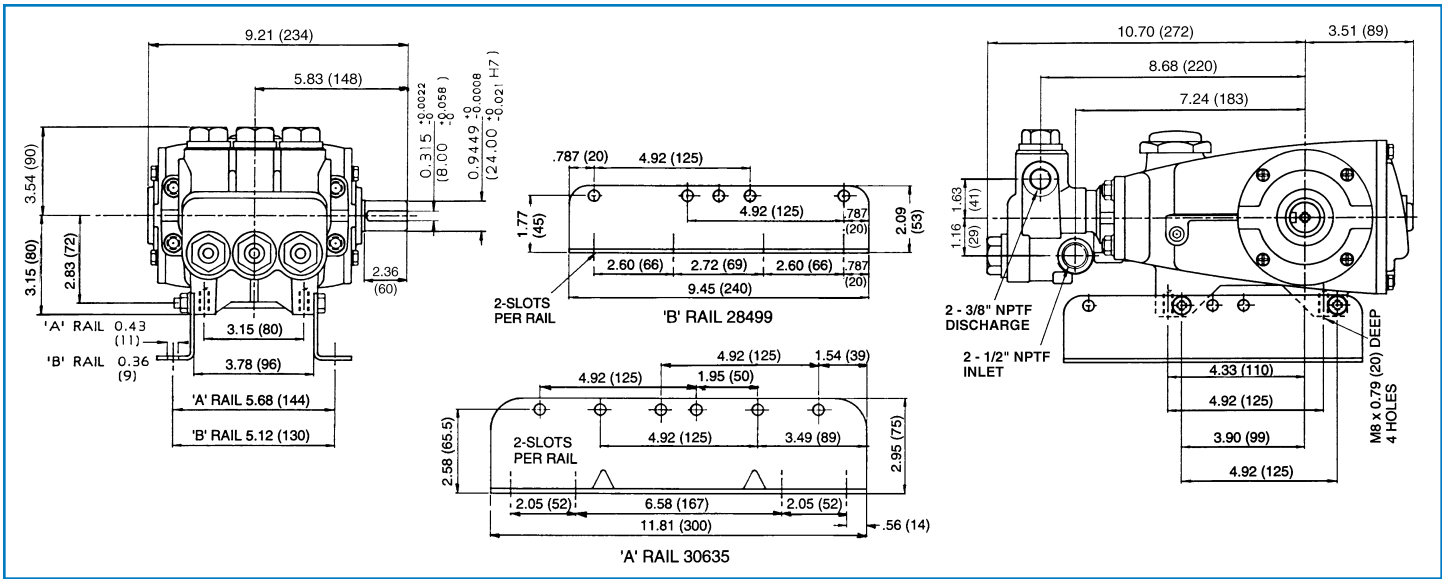

Models 70, 70G1, 70G118

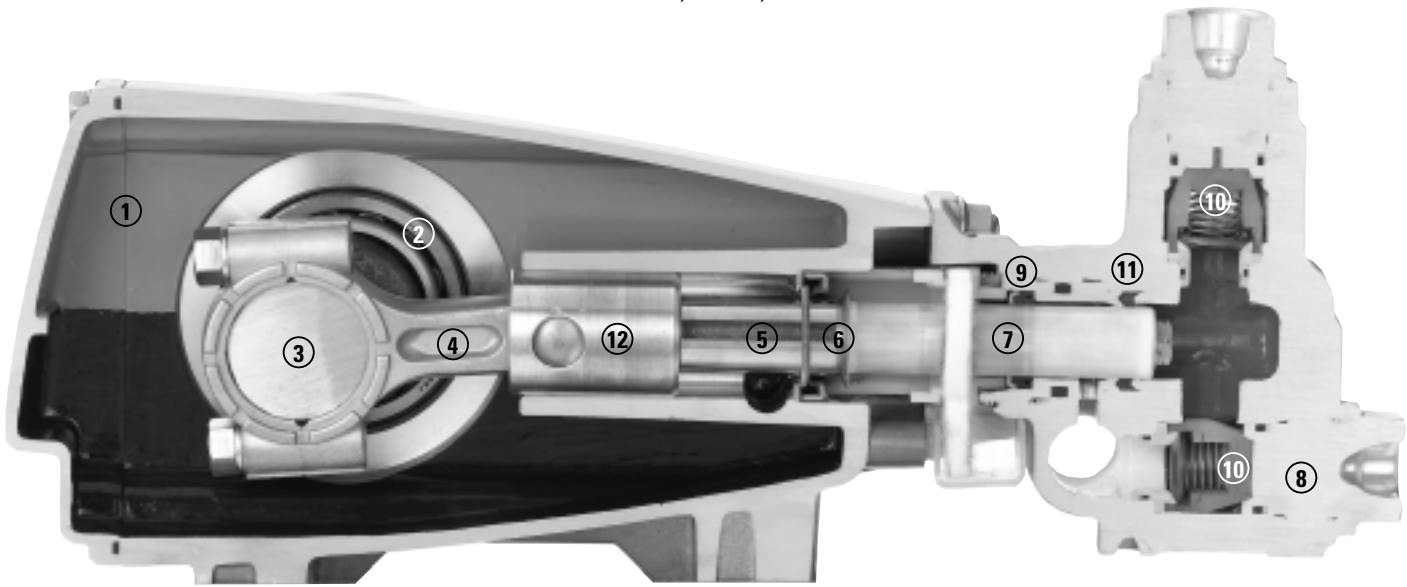

- 1 Die cast aluminum **crankcase** means high strength, light weight, and excellent tolerance control.
- 2 Oversized crankshaft **bearings** provide extended bearing life and pump performance.
- 3 Chrome-moly **crankshaft** provides unmatched strength and surface hardness for long life.
- 4 Matched oversized TNM **connecting rods** noted for superior tensile strength and bearing quality.
- 5 Special stainless steel **plunger rods** with high strength crossheads for longevity and corrosion resistance.
- 6 The stainless steel **slinger** provides back-up protection for the crankcase seal, keeping pumped liquids out of the crankcase.
- 7 Special concentric, high-density, polished, solid ceramic **plungers** provide a true wear surface and extended seal life.
- 8 **Manifolds** are a high tensile strength forged brass for long term, continuous duty.
- 9 100% wet **seal** design adds to service life by allowing pumped liquids to cool and lubricate on both sides.
- 10 Stainless steel **valves, seats and springs** provide corrosion-resistance, ultimate seating and extended life.
- 11 Specially formulated, CAT PUMP exclusive, **V-Packings** offer unmatched performance and seal life.
- 12 **Crossheads** are 360° supported for uncompromising alignment.

World Headquarters

CAT PUMPS

1681 - 94th Lane N.E. Minneapolis, MN 55449-4324

Phone (763) 780-5440 — FAX (763) 780-2958

e-mail: techsupport@catpumps.com

www.catpumps.com

International Inquiries

FAX (763) 785-4329

e-mail: intlsales@catpumps.com



The Pumps with Nine Lives

CAT PUMPS (U.K.) LTD.

1 Fleet Business Park, Sandy Lane, Church Crookham

FLEET, Hampshire, GU52 8BF, England

Phone Fleet 44 1252-622031 — Fax 44 1252-626655

e-mail: sales@catpumps.co.uk

N.V. CAT PUMPS INTERNATIONAL S.A.

Heiveldekens 6A, B-2550 Kontich, Belgium

Phone 32-3-450.71.50 — Fax 32-3-450.71.51

e-mail: cpi@catpumps.be www.catpumps.be

CAT PUMPS DEUTSCHLAND GmbH

Buchwiese 2, D-65510 Idstein, Germany

Phone 49 6126-9303 0 — Fax 49 6126-9303 33

e-mail: catpumps@t-online.de www.catpumps.de